

HITACHI PROGRAMMABLE CONTROLLER

HIDIC EH-150

**Serial Communication Module (EH-SIO)
APPLICATION MANUAL**

NJI-443B(X)

○ Warranty period and coverage

The warranty period is the shorter period either 18 months from the date of manufacture or 12 months from the date of installation.

However within the warranty period, the warranty will be void if the fault is due to;

- (1) Incorrect use as directed in this manual and the application manual.
- (2) Malfunction or failure of external other devices than this unit.
- (3) Attempted repair by unauthorized personnel.
- (4) Natural disasters.

The warranty is for the PLC only, any damage caused to third party equipment by malfunction of the PLC is not covered by the warranty.

○ Repair

Any examination or repair after the warranty period is not covered. And within the warranty period any repair and examination which results in information showing the fault was caused by any of the items mentioned above, the repair and examination cost are not covered. If you have any questions regarding the warranty please contact either your supplier or the local Hitachi Distributor. (Depending on failure part, examination might be impossible.)

○ Ordering parts or asking questions

When contacting us for repair, ordering parts or inquiring about other items, please have the following details ready before contacting the place of purchase.

- (1) Model
- (2) Manufacturing number (MFG no.)
- (3) Details of the malfunction

Warning

- (1) This manual may not be reproduced in its entirety or any portion thereof without prior consent.
- (2) The content of this document may be changed without notice.
- (3) This document has been created with utmost care. However, if errors or questionable areas are found, please contact us.

MS-DOS®, Windows®, and Windows NT® are registered trademarks of America and other registered countries of Microsoft Corp. of the United States.

Safety Precautions

Read this manual and related documents thoroughly before installing, operating, performing preventive maintenance or performing inspection, and be sure to use the unit correctly. Use this product after acquiring adequate knowledge of the unit, all safety information, and all cautionary information. Also, make sure this manual enters the possession of the chief person in charge of safety maintenance.

Safety caution items are classified as “Danger” and “Caution” in this document.



: Cases where if handled incorrectly a dangerous circumstance may be created, resulting in possible death or severe injury.



: Cases where if handled incorrectly a dangerous circumstance may be created, resulting in possible minor to medium injury to the body, or only mechanical damage.

However, depending on the circumstances, items marked with



may result in major accidents.

In any case, they both contain important information, so please follow them closely.

Icons for prohibited items and required items are shown below:



: Indicates prohibited items (items that may not be performed). For example, when open flames are prohibited,



is shown.



: Indicates required items (items that must be performed). For example, when grounding must be performed,



is shown.

1. Attachments

CAUTION

- To be used in environments stipulated in the catalogue and in this document. Usage in environments that subject the equipment to high temperatures, high humidity, dirt and dust, corrosive gas, vibrations and shocks may result in electric shocks, the outbreak of fire and malfunctions.
- Ensure that all attachments are made in accordance with the instructions provided in the instruction manual. If the attachment procedures are ill-prepared, it may result in dropped equipment, damage and malfunctions.
- Ensure that cable clippings and other foreign objects do not enter the equipment. Failure to observe this may result in the outbreak of fire, damage and malfunctions.

2. Wiring

CAUTION

- Ensure that the equipment is connected to a rated power supply. Connecting the equipment to non-rated power supplies may result in the outbreak of fire.
- Ensure that all wiring procedures are performed by qualified technicians. Wrong wiring may result in the outbreak of fire, damage and electric shocks.
- Ensure that the coaxial cable is shielded when installing the link module. As only one side of the shielded cable is to be earthed as a basic principle, attach the earth to the RXD (receiving side.)
- Cover coaxial cables for transmitting between CPU link modules with cloth using a different route than that used by other dynamic or signal cables. If it is not possible to establish a different route, use metal pipes when connecting the wiring.

3. Maintenance

PROHIBITED

- Never dismantle or remodel the equipment. Failure to observe this may result in the outbreak of fire, damage and malfunctions.

CAUTION

- Ensure that the power supply to the modules and units that are to be disconnected has been switched off. Failure to observe this may result in electric shocks, malfunctions and damage.

Contents

Chapter 1 Introduction	1-1 to 1-4
1.1 Before use	1-1
1.2 Feature.....	1-2
1.3 Supported CPU module.....	1-4
1.4 Confirm the software version of EH-SIO.....	1-4
Chapter 2 Specification.....	2-1 to 2-2
2.1 General specification.....	2-1
2.2 Communication specification.....	2-2
Chapter 3 Name and function of each part	3-1 to 3-2
Chapter 4 Installation.....	4-1 to 4-7
4.1 Setup of the communication setting switch.....	4-1
4.2 Mounting the Module.....	4-3
4.3 Connection of the communication port.....	4-4
4.3.1 Connection of the RS-232C interface	4-4
4.3.2 Connection of the RS-422 / 485 interface.....	4-6
Chapter 5 Control of EH-SIO	5-1 to 5-11
5.1 EH-SIO Control command (TRNS 9).....	5-1
5.1.1 Function of command	5-1
5.1.2 TRNS 9 Command format.....	5-3
5.2 Input / Output register	5-7
5.2.1 Register configuration	5-8
5.2.2 Detail of input register	5-9
5.2.3 Detail of output register	5-11
Chapter 6 Communication Mode	6-1 to 6-87
6.1 Introduction.....	6-1
6.2 Free protocol mode	6-3
6.2.1 Overview	6-3
6.2.2 User project structure.....	6-5
6.2.3 Initial setting	6-6
6.2.4 Communication start.....	6-14
6.2.5 Receiving data	6-15
6.2.6 Data Sending.....	6-19
6.2.7 Error detection in free protocol mode.....	6-24

6.3	Modbus master mode	6-26
6.3.1	Overview	6-26
6.3.2	User project structure.....	6-27
6.3.3	Initial setting	6-28
6.3.4	Query transmission, Response reception	6-31
6.3.5	Error detection in modbus master mode	6-43
6.4	Modbus slave mode	6-44
6.4.1	Overview	6-44
6.4.2	User project structure.....	6-47
6.4.3	Initial setting	6-48
6.4.4	Response.....	6-54
6.4.5	Error detection in modbus slave mode.....	6-63
6.5	Hi-Protocol mode.....	6-65
6.5.1	Basic function	6-65
6.5.2	Performance.....	6-67
6.5.3	User project structure.....	6-68
6.5.4	Initial setting	6-69
6.5.5	Error detection in Hi-Protocol mode.....	6-72
6.6	Simple data link mode.....	6-74
6.6.1	Abstract of simple data link	6-75
6.6.2	Performance specification.....	6-77
6.6.3	User project structure.....	6-78
6.6.4	Master configuration (Initial setting of EH-SIO).....	6-79
6.6.5	Configuration of slave station.....	6-85
6.6.6	Error detection in simple data link mode	6-86
Chapter 7 System setup		7-1 to 7-11
7.1	Trial Run	7-1
7.2	Error indication	7-2
7.3	Troubleshooting	7-4
Chapter 8 Daily and Periodic Inspection		8-1 to 8-4
8.1	Daily inspection	8-1
8.2	Periodic inspection	8-1
8.3	Self-check mode	8-2
8.3.1	Check item	8-2
8.3.2	Preparation before self-check	8-3
8.3.3	Starting of self-check mode	8-3
8.3.4	Result of self-check	8-4

Appendix	A-1 to A-29
A.1 ASCII code list.....	A-1
A.2 Outline of Modbus protocol.....	A-2
A.2.1 Modbus message configuration	A-3
A.2.2 Function code	A-3
A.2.3 Error check	A-4
A.2.4 Response message	A-6
A.3 H series protocol (Hi-Protocol).....	A-7
A.3.1 Outline	A-7
A.3.2 Hi-Protocol message configuration.....	A-8
A.3.3 Basic specification of transmission control procedure	A-10
A.3.4 EH-SIO support task code details	A-12
A.3.5 I/O Code List	A-27
A.4 TRNS 9 Return code	A-28

Chapter 1 Introduction

Thank you for using the Hitachi EH-150 Programmable Controller series (It abbreviates to PLC after this.)

This manual explains how to use the serial communication module (It abbreviates to EH-SIO after this.) with the Hitachi EH-150 Programmable Controller. Read this manual thoroughly and keep for installation operations, maintenance checks and other procedures. The following documentation related to PLC is also available and should be used together with this manual.

Table 1.1 List of explanatory documentation

Items	Name of documentation	Number of Manual
Main system of EH-150	EH-150 Application Manual	NJI-281* X
Programming Software	LADDER EDITOR (for MS-DOS)	NJI-206/299
	LADDER EDITOR for Windows®(Windows®95/98/NT4)	NB-325

“*” is version starting from A, B, ...

1.1 Before use

Great care has been taken in the manufacture of this product, but it is advised that the following points are checked immediately after purchase.

1. Is the model the same one that you ordered?
2. Has the product been damaged in any way?
3. Are any of the accessories listed in table 1.2 missing?

Contact your dealer in the event of any defects being discovered.

Table 1.2 List of accessories supplied with the EH-SIO

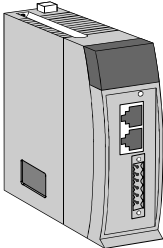
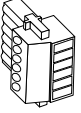
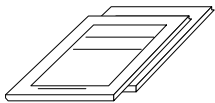
No.	Products name	Model name	Outlook	Pcs	Remarks
1	Serial I/O Interface Module	EH-SIO		1	
2	Connector for RS-422 / 485 Port (Cable side)	BL3.5/6F		1	Widemuller production
3	Instruction manual	NJI-442		1	

« Note »

In order to use EH-SIO, EH-CPU548 (Ver.E402 or newer) / EH-CPU516 (Ver.E202 or newer) is needed. Please confirm the ROM version of your CPU module before using EH-SIO. If the CPU module of ROM version other than the above is used, EH-SIO does not work. Please refer to "1.3 Supported CPU module" for details.

1.2 Feature

EH-SIO is the serial communication module with the following features.

- 2 communication ports

There are two communication ports in EH-SIO. The port 1 is RS-232C interface. The port 2 can be used as RS-232C, RS-422 or 485 interface. Two communication ports can be operated independently and can assign a different function each other.

- Communication operation by user program

Communication with external device is performed by user program. It is controlled by special command "TRNS 9".

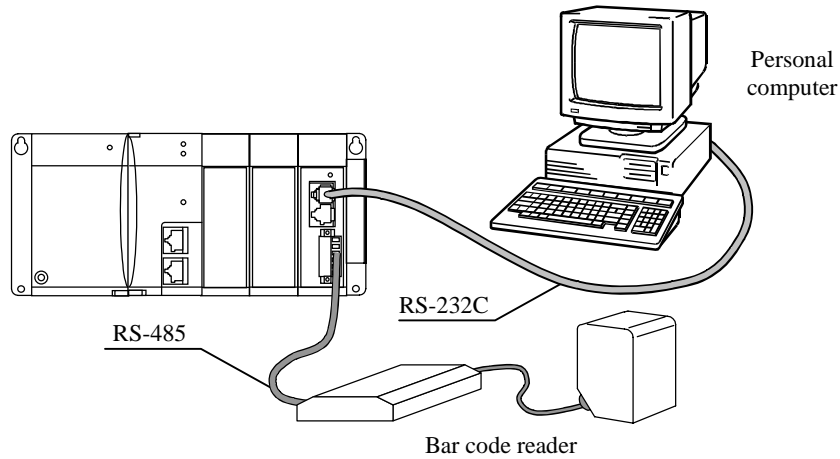

Figure 1.1 System configuration of general-purpose communication

- Exclusive protocol is supported.

Modbus protocol is supported by EH-SIO.

Since EH-SIO can be configured as master or slave, application range of EH-150 will be expanded, such as supervising by host computer or controlling modbus slave.

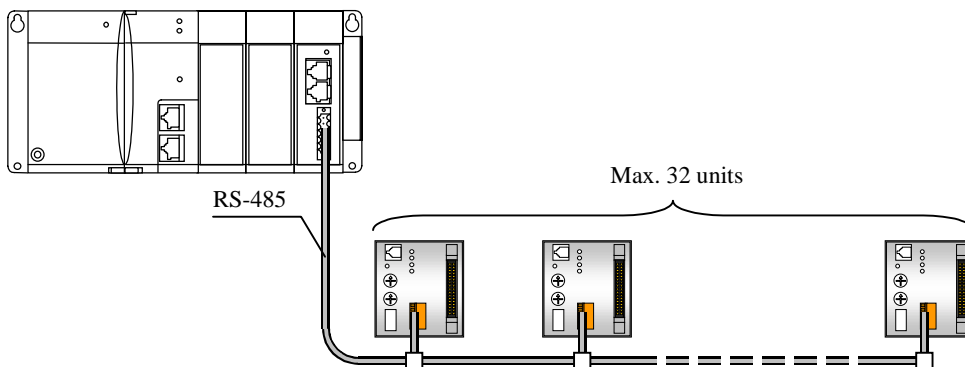

Figure.1.2 System configuration of Modbus protocol application

Reference : What is Modbus?

The Modbus protocol is a communication protocol developed by Modicon Inc. (AEG Schneider Automation International S.A.S.). Only the communication protocol is defined as the modbus protocol. And physical layers, such as a communication medium, are not specified. Please refer to the appendix in the end of this book about a Modbus protocol outline. Please refer to "Modbus Protocol Reference Guide" (PI-MBUS -300) of Modicon Inc. issue for further information.

■ Exclusive protocol for H / EH series (Hi-Protocol) is supported.

EH-SIO can communicate with HMI (Human Machine Interface) which supports H / EH series communication procedure (transmission control procedure 1).

For example, it is convenient when using two or more touch panels to be connected. Moreover, since EH-SIO can be mounted also in an expansion base, system expansion is very flexible.

* Transmission control procedures 2 is supported by the software version 2.1 or newer.

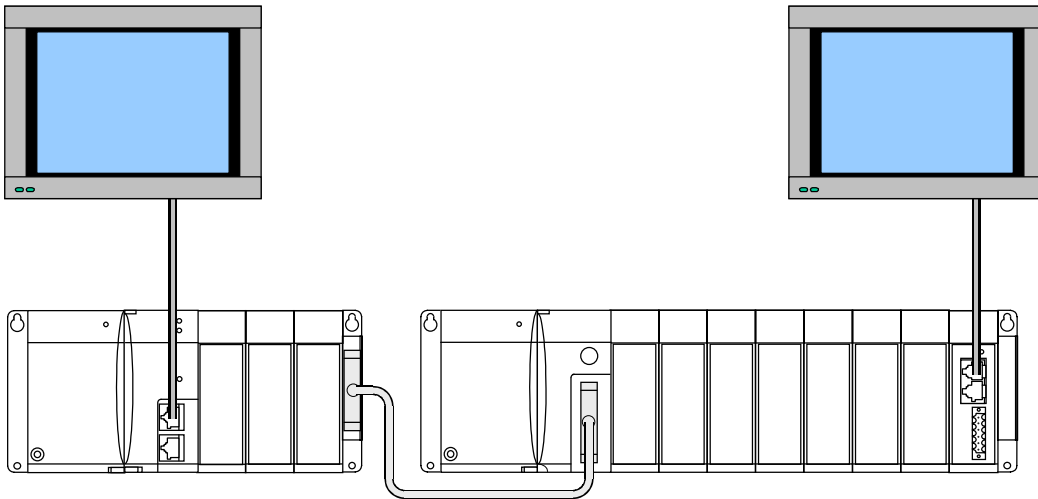

Figure.1.3 System configuration of Hi-Protocol application

« Note »

Programming tools, such as the LADDER EDITOR, are not connectable with EH-SIO.

■ Simple Data Link function

The simple data link is the function to make EH-SIO into a master and to exchange I/O information for the slave by communication.

The models of PLC used as the slave are EH-150* and MICRO-EH*. Completion of initial setting of EH-SIO which becomes a master updates I/O area automatically by the system.

* The model which is supporting transmission control procedures 2 (with a station No.) is required.

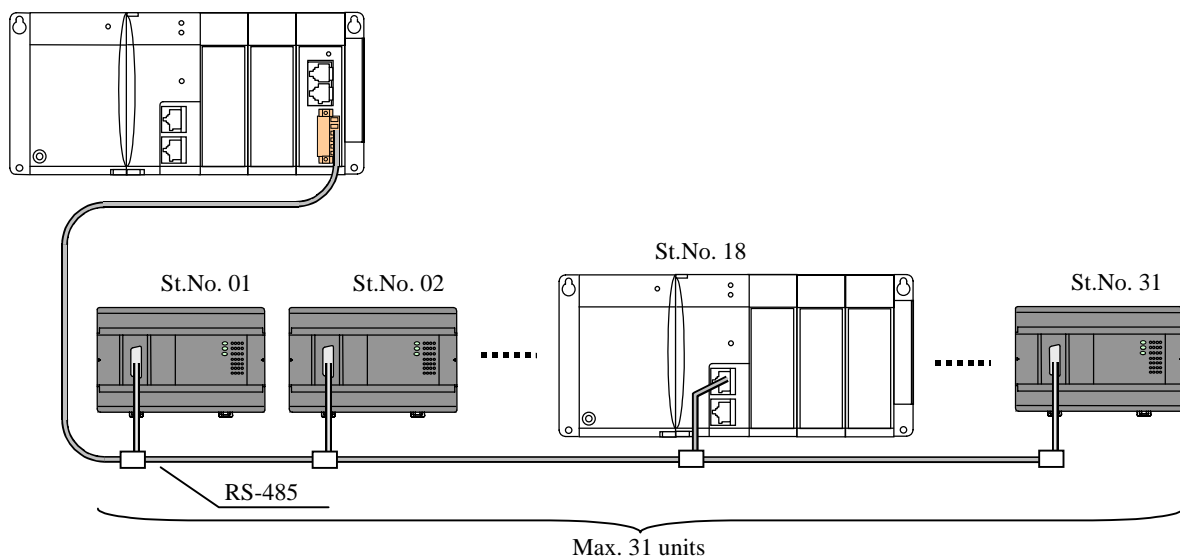

Figure.1.4 System configuration of Simple Data Link

1.3 Supported CPU module

The function of EH-SIO depends on software version of CPU shown in the following table. The function of EH-SIO and the software version of EH-CPU which can be responded are shown in the following table.

Table.1.3 The function of EH-SIO and correspondence CPU module

Function of EH-SIO	Version			Supported CPU module	
	1.0	2.0	2.1	EH-CPU516 (Ver. E2.02 - E2.06) EH-CPU548 (Ver. E4.02 - E4.05)	EH-CPU516 (Ver. E2.07 or newer) EH-CPU548 (Ver. E4.06 or newer)
Free-Protocol	✓	✓	✓	✓	✓
Modbus Master (RTU)	✓	✓	✓	✓	✓
Modbus Master (ASCII)		✓	✓	✓	✓
Modbus Slave (RTU)	✓	✓	✓	✓	✓
Modbus Slave (ASCII)		✓	✓	✓	✓
Modbus Slave (I/O mapping)		✓	✓	✓	✓
Hi-Protocol (procedure 1)		✓	✓		✓
Hi-Protocol (procedure 2)			✓		✓
Simple data link		✓	✓		✓
Self-check			✓	Not depend on the software version of CPU.	

« Remark »

As for the operating of combining with the CPU module which is not supporting the function of EH-SIO, please refer to "Combination with a CPU module" of "7.3 Troubleshooting".

1.4 Confirm the software version of EH-SIO

The software version is indicated in the main label of the module side.

In addition, it can be monitored in WXus3 before initial setting is completed.

* u : Unit No., s : Slot No.

Ex.) WXus3 : H0010 → Ver. 1.0

WXus3 : H0020 → Ver. 2.0

« Note »

Software version cannot be monitored after initial setting is completed. The following procedures are required to confirm a version after initial setting completion. (in the status of the waiting for initial setting.)

- ◆ Free protocol mode ... To stop EH-CPU
- ◆ Modbus master mode ... To stop EH-CPU
- ◆ Modbus slave mode ... To reset EH-SIO
- ◆ Hi-Protocol mode ... To reset EH-SIO
- ◆ Simple data link mode ... To reset EH-SIO

Reference : Description of I/O No.

In this book, the sign "u" and "s" is used for expressing arbitrary I/O number. "u" means unit number and "s" means slot number.

I/O assignment of EH-SIO is WORD 4W/4W. For example, if EH-SIO is mounted in the unit 1 and the slot 7, I/O No. is set to WX170-WX173 and WY174-WY177.

(In this book, it is expressed as WXus0 - WXus3 and WYus4 - WYus7.)

Chapter 2 Specification

The general specification and transmission specification of EH-SIO are shown below.

2.1 General specification

Table 2.1 General Specification

ITEM	SPECIFICATION
Operating temperature	0 to 55°C
Preserving temperature	-10 to 75°C
Operating humidity	No condensation 20 to 90% RH
Preserving humidity	No condensation 10 to 90% RH
Current consumption	5V DC Approx. 250 mA
Mounted slot position	Basic base, Expansion base (Not possible on remote base. (EH-IOCD, EH-IOCP))
The number of mounting	With no restrictions until maximum of I/O numbers. (In case of Modbus slave mode, Hi-Protocol mode*1*2, Simple Data Link mode*1, Max. 8 units)
Number of occupation permitted I/O points.	128 points.
I/O assignment	Word 4W/4W
Unusual detection	Processor abnormal, Watch dog timer error, System ROM/RAM abnormal, Communication data error (parity error, framing error, over run, and so on.)
Supported communication mode	Free protocol, Modbus (RTU/ASCII*1) master / slave, Hi-Protocol (Transmission control procedure 1*1 / 2*2), Simple Data Link*1

*1 : This function supported from software Ver.2.0.

*2 : This function supported from software Ver.2.1.

« Note »

- ◆ Total current consumption can be over the capacity of power supply module depending on module configuration. Be sure to check that the total current is less than the maximum output current of power supply module.
- ◆ In order to use a part of function of EH-SIO supported by software Ver.2.0, CPU module corresponding to the this function is required. Please refer to "1.3 Supported CPU module" for details.

2.2 Communication specification

Table 2.2 Communication specification

ITEM	SPECIFICATION													
Interface	Conforms to RS-232C (2 ports *)	Conforms to RS-422 (1 port *)	Conforms to RS-485 (1 port *)											
Transmission speed	300, 600, 1,200, 2,400, 4,800, 9,600, 19,200, 38,400, 57,600 bps													
Startup method	One-sided startup using the host side command													
Transmission method	Serial transmission (bit serial transmission)													
Transmission code	ASCII, binary													
Transmission code configuration	<p style="text-align: center;">Transmission data 7 or 8 bits</p> <table border="1" style="margin-left: auto; margin-right: auto;"> <tr> <td>a</td> <td>2⁰</td> <td>2¹</td> <td>2²</td> <td>2³</td> <td>2⁴</td> <td>2⁵</td> <td>2⁶</td> <td>2⁷</td> <td>b</td> <td>c</td> </tr> </table> <p>a: Start bit b: Parity bit (Even, Odd, None) c: Stop bit (1 or 2)</p>			a	2 ⁰	2 ¹	2 ²	2 ³	2 ⁴	2 ⁵	2 ⁶	2 ⁷	b	c
a	2 ⁰	2 ¹	2 ²	2 ³	2 ⁴	2 ⁵	2 ⁶	2 ⁷	b	c				
Input buffer	1,024 bytes / 1 port													
Output buffer	1,024 bytes / 1 port													
Error control	Vertical parity check, framing check, overrun check, Input buffer full check, Message error check, Timeout error check													
Connection mode	1:1	1:1	1:N (Max.32 units.)											
Max cable length	15 m	500 m												
Body side connector	TM5RSB-1616 8-pin modular connector	SL3.5/6/90F Pitch 3.5, 6-poles with screw												

* Port 2 chooses either a RS-232C port or RS-422/485 port in DIP Sw. RS-422 and RS-485 are switched by wiring.

Chapter 3 Name and function of each part

	Type	EH-SIO
	Weight	Approx. 0.13 kg
	Dimensions (mm)	

No.	Name	Function	Remark	
[1]	Lock button	When dismantling the module from a base unit, press this button and lift up the module. The module can be fixed firmly by a screw (M4, 10mm)		
[2]	State display LED	It is LED which displays the state of module. Please refer to the following page for details.		
[3]	Reset switch	Reset the module.		
[4]	Port 1	RS-232C Port	The transmission cable of RS-232C is connected.	
[5]	Port 2	RS-232C Port	The transmission cable of RS-232C is connected.	Select using the Communication setting switch.
[6]		RS-422/485 Port	The transmission cable of RS-422 / 485 is connected.	
[7]	Communication setting switch	It is used in order to set up transmission speed, transmission code configuration, etc. Please refer to the “ Chapter 4 Installation” for details.		

■ Display of LED

Table 3.1 Contents of LED display

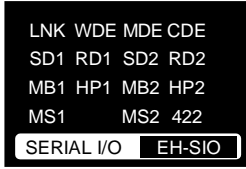
Appearance	LED	Contents of display	Details	Color
	LNK	Simple data link mode operation*	In the case of under simple data link mode operation, This LED is turned on.	Green
	WDE	Watch dog time error	When the watchdog timer detected a microcomputer overload, this LED is turned on. (Port 1 / Port 2 common use)	Red
	MDE	Module error	When abnormalities (minor failure) occur to the module, this LED is turned on. (Port 1 / Port 2 common use)	Red
	CDE	Command error	When the command error (warning) occur to the module, this LED is turned on. (Port 1 / Port 2 common use)	Red
	SD1	Data transmission	It blinks, while transmitting data from a port 1.	Green
	RD1	Data reception	It blinks, while a port 1 receives data.	Green
	MB1	Modbus mode operation	In the case of under Modbus mode operation, This LED is turned on. (Port 1)	Green
	HP1	Hi-protocol mode operation*	In the case of under Hi-protocol mode operation, This LED is turned on. (Port 1)	Green
	MS1	Master mode operation	In the case of under master mode operation, This LED is turned on. (Port 1)	Green
	SD2	Data transmission	It blinks, while transmitting data from a port 2.	Green
	RD2	Data reception	It blinks, while a port 2 receives data.	Green
	MB2	Modbus mode operation	In the case of under Modbus mode operation, This LED is turned on. (Port 2)	Green
	HP2	Hi-protocol mode operation*	In the case of under Hi-protocol mode operation, This LED is turned on. (Port 2)	Green
	MS2	Master mode operation	In the case of under master mode operation, This LED is turned on. (Port 2)	Green
422	RS-422 / 485 I/F operation	When the RS-422/485 interface is selected for Port2, this LED is turned on.	Green	

* "Hi-Protocol" and "Simple data link" mode are supported by ver. 2.0 or newer.

When power supply turned on, state display LED except ERR, RD, SD are turned on. ("422" is turned on or off according to the state of a communication setting switch.) By executing initial setting, LED other than the set-up communication mode turned off.

Please refer to "Chapter 7 System setup" about error LED (WDE, MDE, CDE).

Chapter 4 Installation

4.1 Setup of the communication setting switch

Transmission speed and transmission code configuration are set up with the communication setting switch at the side of the module.

There are 2 pieces of communication setting switches mounted. DIPSW1 is a setting switch for port 1 and DIPSW2 is for port 2. In case of set up, please remove a module from a base.

⚠ The module consists of precise electronic products. When you set up this switch, please don't touch any parts around the communication setting switch.

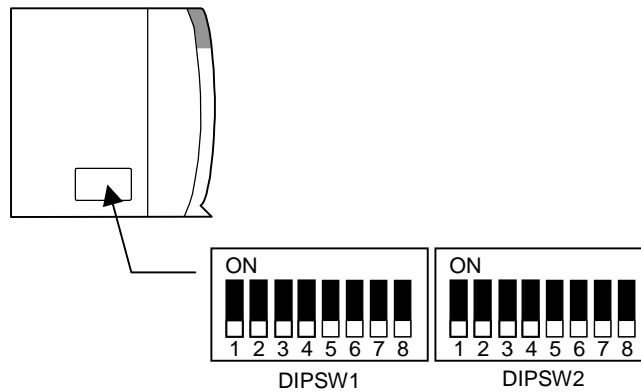
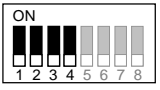



Figure 4.1 Communication setting switch

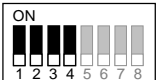
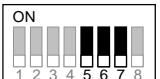

Table 4.1 Setup of the communication setting switch (Port 1)

No.	Setup contents	Details																																																																																					
1	Transmission speed	<p>Bit 1, 2, 3, 4 are used for setting of transmission speed of port 1.</p>  <table border="1" style="margin-left: 20px;"> <thead> <tr> <th>Bit1</th> <th>Bit2</th> <th>Bit3</th> <th>Bit4</th> <th>Transmission speed</th> </tr> </thead> <tbody> <tr><td>OFF</td><td>OFF</td><td>OFF</td><td>OFF</td><td>(Not used)</td></tr> <tr><td>OFF</td><td>OFF</td><td>OFF</td><td>ON</td><td>300 bps</td></tr> <tr><td>OFF</td><td>OFF</td><td>ON</td><td>OFF</td><td>600 bps</td></tr> <tr><td>OFF</td><td>OFF</td><td>ON</td><td>ON</td><td>1,200 bps</td></tr> <tr><td>OFF</td><td>ON</td><td>OFF</td><td>OFF</td><td>2,400 bps</td></tr> <tr><td>OFF</td><td>ON</td><td>OFF</td><td>ON</td><td>4,800 bps</td></tr> <tr><td>OFF</td><td>ON</td><td>ON</td><td>OFF</td><td>9,600 bps</td></tr> <tr><td>OFF</td><td>ON</td><td>ON</td><td>ON</td><td>19,200 bps</td></tr> <tr><td>ON</td><td>OFF</td><td>OFF</td><td>OFF</td><td>38,400 bps</td></tr> <tr><td>ON</td><td>OFF</td><td>OFF</td><td>ON</td><td>57,600 bps</td></tr> <tr><td>ON</td><td>OFF</td><td>ON</td><td>OFF</td><td>(Not used)</td></tr> <tr><td>ON</td><td>OFF</td><td>ON</td><td>ON</td><td></td></tr> <tr><td>ON</td><td>ON</td><td>OFF</td><td>OFF</td><td></td></tr> <tr><td>ON</td><td>ON</td><td>OFF</td><td>ON</td><td></td></tr> <tr><td>ON</td><td>ON</td><td>ON</td><td>OFF</td><td></td></tr> <tr><td>ON</td><td>ON</td><td>ON</td><td>ON</td><td></td></tr> </tbody> </table>	Bit1	Bit2	Bit3	Bit4	Transmission speed	OFF	OFF	OFF	OFF	(Not used)	OFF	OFF	OFF	ON	300 bps	OFF	OFF	ON	OFF	600 bps	OFF	OFF	ON	ON	1,200 bps	OFF	ON	OFF	OFF	2,400 bps	OFF	ON	OFF	ON	4,800 bps	OFF	ON	ON	OFF	9,600 bps	OFF	ON	ON	ON	19,200 bps	ON	OFF	OFF	OFF	38,400 bps	ON	OFF	OFF	ON	57,600 bps	ON	OFF	ON	OFF	(Not used)	ON	OFF	ON	ON		ON	ON	OFF	OFF		ON	ON	OFF	ON		ON	ON	ON	OFF		ON	ON	ON	ON	
Bit1	Bit2	Bit3	Bit4	Transmission speed																																																																																			
OFF	OFF	OFF	OFF	(Not used)																																																																																			
OFF	OFF	OFF	ON	300 bps																																																																																			
OFF	OFF	ON	OFF	600 bps																																																																																			
OFF	OFF	ON	ON	1,200 bps																																																																																			
OFF	ON	OFF	OFF	2,400 bps																																																																																			
OFF	ON	OFF	ON	4,800 bps																																																																																			
OFF	ON	ON	OFF	9,600 bps																																																																																			
OFF	ON	ON	ON	19,200 bps																																																																																			
ON	OFF	OFF	OFF	38,400 bps																																																																																			
ON	OFF	OFF	ON	57,600 bps																																																																																			
ON	OFF	ON	OFF	(Not used)																																																																																			
ON	OFF	ON	ON																																																																																				
ON	ON	OFF	OFF																																																																																				
ON	ON	OFF	ON																																																																																				
ON	ON	ON	OFF																																																																																				
ON	ON	ON	ON																																																																																				
2	Transmission code configuration	<p>Bit5, 6, 7 are used for setting of transmission code configuration of port 1.</p>  <table border="1" style="margin-left: 20px;"> <thead> <tr> <th rowspan="2">Bit5</th> <th rowspan="2">Bit6</th> <th rowspan="2">Bit7</th> <th colspan="3">Transmission code configuration</th> </tr> <tr> <th>Data length</th> <th>Stop bit</th> <th>Kind of parity bit</th> </tr> </thead> <tbody> <tr><td>OFF</td><td>OFF</td><td>OFF</td><td>7</td><td>2</td><td>Even</td></tr> <tr><td>OFF</td><td>OFF</td><td>ON</td><td>7</td><td>2</td><td>Odd</td></tr> <tr><td>OFF</td><td>ON</td><td>OFF</td><td>7</td><td>1</td><td>Even</td></tr> <tr><td>OFF</td><td>ON</td><td>ON</td><td>7</td><td>1</td><td>Odd</td></tr> <tr><td>ON</td><td>OFF</td><td>OFF</td><td>8</td><td>2</td><td>None</td></tr> <tr><td>ON</td><td>OFF</td><td>ON</td><td>8</td><td>1</td><td>None</td></tr> <tr><td>ON</td><td>ON</td><td>OFF</td><td>8</td><td>1</td><td>Even</td></tr> <tr><td>ON</td><td>ON</td><td>ON</td><td>8</td><td>1</td><td>Odd</td></tr> </tbody> </table>	Bit5	Bit6	Bit7	Transmission code configuration			Data length	Stop bit	Kind of parity bit	OFF	OFF	OFF	7	2	Even	OFF	OFF	ON	7	2	Odd	OFF	ON	OFF	7	1	Even	OFF	ON	ON	7	1	Odd	ON	OFF	OFF	8	2	None	ON	OFF	ON	8	1	None	ON	ON	OFF	8	1	Even	ON	ON	ON	8	1	Odd																												
Bit5	Bit6	Bit7				Transmission code configuration																																																																																	
			Data length	Stop bit	Kind of parity bit																																																																																		
OFF	OFF	OFF	7	2	Even																																																																																		
OFF	OFF	ON	7	2	Odd																																																																																		
OFF	ON	OFF	7	1	Even																																																																																		
OFF	ON	ON	7	1	Odd																																																																																		
ON	OFF	OFF	8	2	None																																																																																		
ON	OFF	ON	8	1	None																																																																																		
ON	ON	OFF	8	1	Even																																																																																		
ON	ON	ON	8	1	Odd																																																																																		

« Note »

If bit-7 and 8 of DIP Sw1 are ON, EH-SIO will start up with self-check mode. Communication with external devices and data transmission with CPU are not performed during self-check mode execution. Please refer to “8.3 Self-check mode” for further information.

Table 4.2 Setup of the communication setting switch (Port 2)

No.	Setup contents	Details																																																																																					
1	Transmission speed	<p>Bit 1, 2, 3, 4 are used for setting of transmission speed of port 2.</p>  <table border="1"> <thead> <tr> <th>Bit1</th> <th>Bit2</th> <th>Bit3</th> <th>Bit4</th> <th>Transmission speed</th> </tr> </thead> <tbody> <tr><td>OFF</td><td>OFF</td><td>OFF</td><td>OFF</td><td>(Not used)</td></tr> <tr><td>OFF</td><td>OFF</td><td>OFF</td><td>ON</td><td>300 bps</td></tr> <tr><td>OFF</td><td>OFF</td><td>ON</td><td>OFF</td><td>600 bps</td></tr> <tr><td>OFF</td><td>OFF</td><td>ON</td><td>ON</td><td>1,200 bps</td></tr> <tr><td>OFF</td><td>ON</td><td>OFF</td><td>OFF</td><td>2,400 bps</td></tr> <tr><td>OFF</td><td>ON</td><td>OFF</td><td>ON</td><td>4,800 bps</td></tr> <tr><td>OFF</td><td>ON</td><td>ON</td><td>OFF</td><td>9,600 bps</td></tr> <tr><td>OFF</td><td>ON</td><td>ON</td><td>ON</td><td>19,200 bps</td></tr> <tr><td>ON</td><td>OFF</td><td>OFF</td><td>OFF</td><td>38,400 bps</td></tr> <tr><td>ON</td><td>OFF</td><td>OFF</td><td>ON</td><td>57,600 bps</td></tr> <tr><td>ON</td><td>OFF</td><td>ON</td><td>OFF</td><td>(Not used)</td></tr> <tr><td>ON</td><td>OFF</td><td>ON</td><td>ON</td><td></td></tr> <tr><td>ON</td><td>ON</td><td>OFF</td><td>OFF</td><td></td></tr> <tr><td>ON</td><td>ON</td><td>OFF</td><td>ON</td><td></td></tr> <tr><td>ON</td><td>ON</td><td>ON</td><td>OFF</td><td></td></tr> <tr><td>ON</td><td>ON</td><td>ON</td><td>ON</td><td></td></tr> </tbody> </table>	Bit1	Bit2	Bit3	Bit4	Transmission speed	OFF	OFF	OFF	OFF	(Not used)	OFF	OFF	OFF	ON	300 bps	OFF	OFF	ON	OFF	600 bps	OFF	OFF	ON	ON	1,200 bps	OFF	ON	OFF	OFF	2,400 bps	OFF	ON	OFF	ON	4,800 bps	OFF	ON	ON	OFF	9,600 bps	OFF	ON	ON	ON	19,200 bps	ON	OFF	OFF	OFF	38,400 bps	ON	OFF	OFF	ON	57,600 bps	ON	OFF	ON	OFF	(Not used)	ON	OFF	ON	ON		ON	ON	OFF	OFF		ON	ON	OFF	ON		ON	ON	ON	OFF		ON	ON	ON	ON	
Bit1	Bit2	Bit3	Bit4	Transmission speed																																																																																			
OFF	OFF	OFF	OFF	(Not used)																																																																																			
OFF	OFF	OFF	ON	300 bps																																																																																			
OFF	OFF	ON	OFF	600 bps																																																																																			
OFF	OFF	ON	ON	1,200 bps																																																																																			
OFF	ON	OFF	OFF	2,400 bps																																																																																			
OFF	ON	OFF	ON	4,800 bps																																																																																			
OFF	ON	ON	OFF	9,600 bps																																																																																			
OFF	ON	ON	ON	19,200 bps																																																																																			
ON	OFF	OFF	OFF	38,400 bps																																																																																			
ON	OFF	OFF	ON	57,600 bps																																																																																			
ON	OFF	ON	OFF	(Not used)																																																																																			
ON	OFF	ON	ON																																																																																				
ON	ON	OFF	OFF																																																																																				
ON	ON	OFF	ON																																																																																				
ON	ON	ON	OFF																																																																																				
ON	ON	ON	ON																																																																																				
2	Transmission code configuration	<p>Bit5, 6, 7 are used for setting of transmission code configuration of port 2.</p>  <table border="1"> <thead> <tr> <th rowspan="2">Bit5</th> <th rowspan="2">Bit6</th> <th rowspan="2">Bit7</th> <th colspan="3">Transmission code configuration</th> </tr> <tr> <th>Data length</th> <th>Stop bit</th> <th>Kind of parity bit</th> </tr> </thead> <tbody> <tr><td>OFF</td><td>OFF</td><td>OFF</td><td>7</td><td>2</td><td>Even</td></tr> <tr><td>OFF</td><td>OFF</td><td>ON</td><td>7</td><td>2</td><td>Odd</td></tr> <tr><td>OFF</td><td>ON</td><td>OFF</td><td>7</td><td>1</td><td>Even</td></tr> <tr><td>OFF</td><td>ON</td><td>ON</td><td>7</td><td>1</td><td>Odd</td></tr> <tr><td>ON</td><td>OFF</td><td>OFF</td><td>8</td><td>2</td><td>None</td></tr> <tr><td>ON</td><td>OFF</td><td>ON</td><td>8</td><td>1</td><td>None</td></tr> <tr><td>ON</td><td>ON</td><td>OFF</td><td>8</td><td>1</td><td>Even</td></tr> <tr><td>ON</td><td>ON</td><td>ON</td><td>8</td><td>1</td><td>Odd</td></tr> </tbody> </table>	Bit5	Bit6	Bit7	Transmission code configuration			Data length	Stop bit	Kind of parity bit	OFF	OFF	OFF	7	2	Even	OFF	OFF	ON	7	2	Odd	OFF	ON	OFF	7	1	Even	OFF	ON	ON	7	1	Odd	ON	OFF	OFF	8	2	None	ON	OFF	ON	8	1	None	ON	ON	OFF	8	1	Even	ON	ON	ON	8	1	Odd																												
Bit5	Bit6	Bit7				Transmission code configuration																																																																																	
			Data length	Stop bit	Kind of parity bit																																																																																		
OFF	OFF	OFF	7	2	Even																																																																																		
OFF	OFF	ON	7	2	Odd																																																																																		
OFF	ON	OFF	7	1	Even																																																																																		
OFF	ON	ON	7	1	Odd																																																																																		
ON	OFF	OFF	8	2	None																																																																																		
ON	OFF	ON	8	1	None																																																																																		
ON	ON	OFF	8	1	Even																																																																																		
ON	ON	ON	8	1	Odd																																																																																		
3	Communication I/F for Port2	<p>Bit 8 is used for I/F selection (RS-232C, or RS-422/485) of a port 2. (RS-422 or RS-485 are decided by external wiring.)</p>  <table border="1"> <thead> <tr> <th>Bit8</th> <th>Communication I/F for Port2</th> </tr> </thead> <tbody> <tr><td>OFF</td><td>RS-232C Port</td></tr> <tr><td>ON</td><td>RS-422 / RS-485Port</td></tr> </tbody> </table>	Bit8	Communication I/F for Port2	OFF	RS-232C Port	ON	RS-422 / RS-485Port																																																																															
Bit8	Communication I/F for Port2																																																																																						
OFF	RS-232C Port																																																																																						
ON	RS-422 / RS-485Port																																																																																						

4.2 Mounting the Module

How to attach a module and how to remove are shown below.

(1) Attach

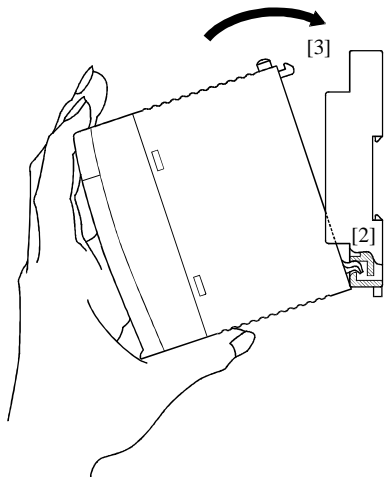

[1] Please check whether there are any abnormalities in a base side connector or a module side connector.

[2] Hook the bottom part of the module to the hole in the base.

[3] Press in the upper side of the module until it clicks.

Note 1 : If abnormalities should be in a connector part, please contact your local supplier.

Note 2 : Please check that a module does not separate after attaching a module.

(2) Remove

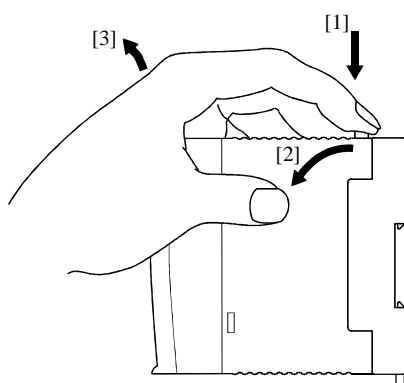

[1] Push in the lock button.

[2] With the lock button pushed in, pull the top of the module toward the front.

[3] Raise it toward the top and pull it out.

« Note »

- ◆ EH-SIO is supported by a basic base and an extension base. It does not work on the remote base where EH-IOCD (DeviceNet slave controller) or EH-IOCP (Profibus slave controller) is mounted.
- ◆ Total current consumption can be over the capacity of power supply module depending on module configuration. Be sure to check that the total current is less than the maximum output current of power supply module.

4.3 Connection of the communication port

4.3.1 Connection of the RS-232C interface

The port 1 is fixed as RS-232C interface. The port 2 is selectable as RS-232C or RS-422 / 485.

Table 4.3 RS-232C interface

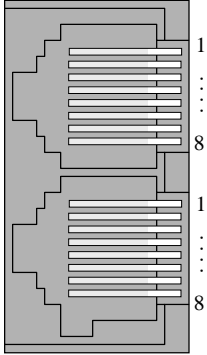
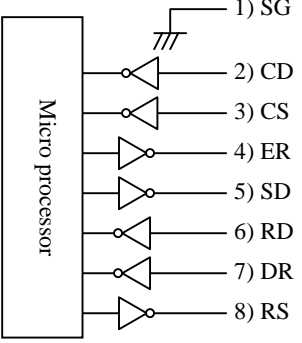
Terminal layout	No.	Symbol	Signal name	Diagram of Internal circuit
	1	SG	Ground for signal	
	2	CD	Carrier detect	
	3	CS	Clear to Send	
	4	ER	Communication enabled signal	
	5	SD	Data sent from EH-SIO	
	6	RD	Data received by EH-SIO	
	7	DR	Peripheral units connected signal	
	8	RS	Transmission request signal	

■ Signal name and Connector pin arrangement

Table 4.4 Signal name (EH-SIO side) and connector pin arrangement (RS-232C Port)

Pin No.	Signal Name	Symbol	Signal Direction		Specifications
			EH-SIO	External device	
1	Signal for Ground	SG	--	--	Ground for communication
2	Carrier Detect* ²	CD	←	←	A career is detected while it is connectable with the external device. EH-SIO does not receive data when it is Low.
3	Clear to Send* ²	CS	←	←	It means that external device can be received. EH-SIO does not transmit data when it is Low.
4	Data Terminal Ready* ²	ER* ¹	→	→	It means that data (or command) is receivable. Control by the user program is possible.
5	Send Data	SD	→	→	Data from EH-SIO.
6	Received Data	RD	←	←	Data from external device.
7	Data set Ready* ²	DR	←	←	It means that external device can operate. It becomes "port connection error" at the time of Low.
8	Request to Send* ²	RS* ¹	→	→	This signal is turned on to transmit data. Control by the user program is possible.

*1 When EH-SIO operates in free protocol mode, RS and ER can be controlled by the control register. (A setup always turned on is also possible.) Please refer to "5.2.3 Detail of output register".

*2 When EH-SIO operates in Modbus mode, a control signal does not use. (It communicates without being dependent on the state of each signal.) Moreover, in the case of Hi-Protocol mode, ER, DR, and RS are watched and controlled.

⚠ When using in Hi-Protocol mode

There is a signal line by which the input / output directions differ in the communication port of EH-CPU and EH-SIO. (Pin No.3)

Even if you are a cable with the actual result which communicated with EH-CPU, please be sure to check the signal line of a cable.

■ The example of cable connection

(1) When connecting with the general-purpose port of a personal computer

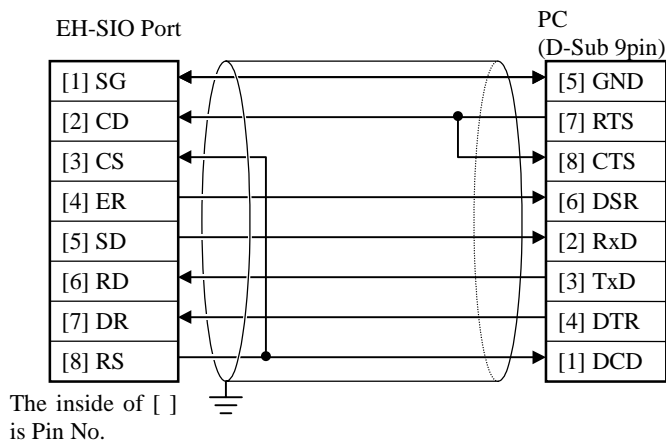

(2) When connecting with the modem

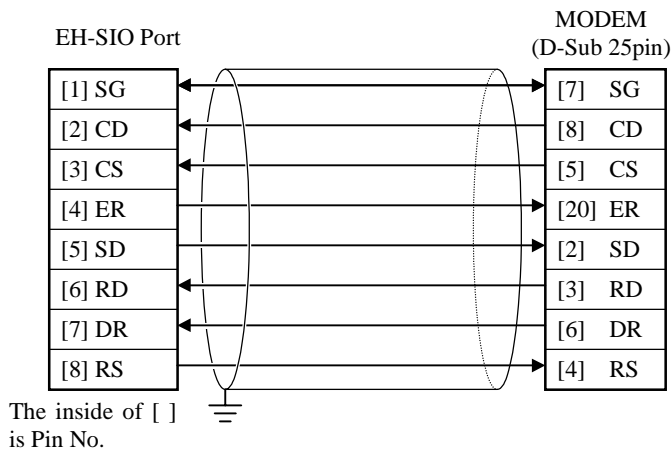

(3) When a control signal is not used

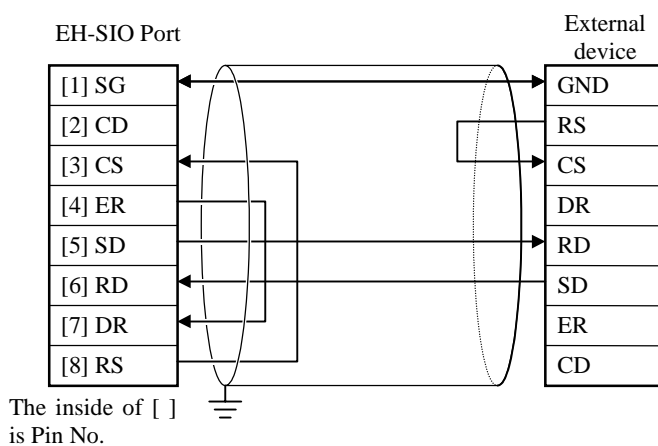

Note :

Please make a shield part one end grounding in principle. However, both-ends grounding or no grounding may be effective by the noise. Please choose the suitable grounding method according to environment.

4.3.2 Connection of the RS-422 / 485 interface

The port 2 can select a communication interface. When you use RS-422 or RS-485 interface, please set up with a communication setting switch. In addition, RS-422 or RS-485 interface is decided by connection of signal.

Table 4.5 RS-422/485 Signal

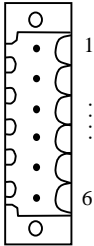
Terminal layout	No.	Signal	Signal Name	Diagram of internal circuit
	1	SD +	Send data +	
	2	SD -	Send data -	
	3	RD +	Receive data +	
	4	RD -	Receive data -	
	5	TERM	Built-in terminator	
	6	SG	Ground for signal	

■ Signal name and Connector pin arrangement

Table 4.6 Signal name (EH-SIO side) and connector pin arrangement (RS-422/485 Port)

Pin No.	Signal Name	Symbol	Signal Direction		Specifications
			EH-SIO	External device	
1	Send data +	SD +	→	→	Data send from EH-SIO.
2	Send data -	SD -	→	→	Data send from EH-SIO.
3	Receive data +	RD +	←	←	Data received from external device.
4	Receive data -	RD -	←	←	Data received from external device.
5	Built-in terminator	TERM	(→ RD -)	--	When you use built-in terminator, please connect with RD -.
6	Ground for signal	SG	--	--	Ground for signal

« Note »

A communication cable should use the twisted pair wire with a shield.

■ The example of cable connection

The example of cable connection of RS-422 I/F and RS-485 I/F is shown below.

Additional terminal block is useful for multi-drop communication.

(1) When connecting in RS-422 I/F

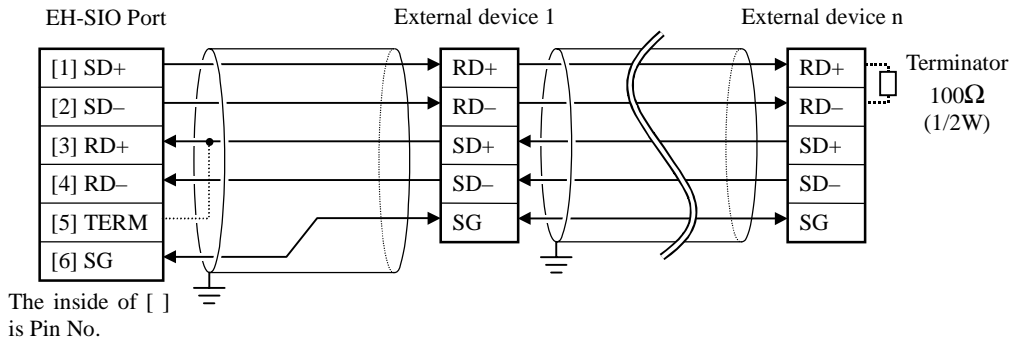

Please attach terminator if needed.

(2) When connecting in RS-485 I/F

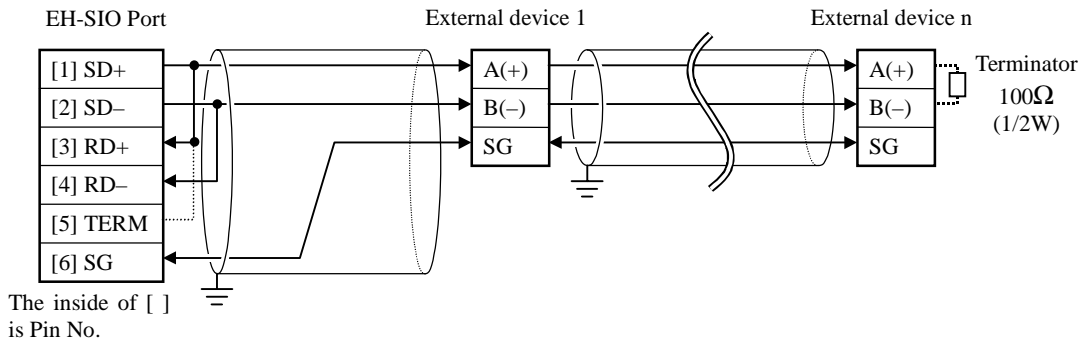

Please attach terminator if needed.

« Note »

Please make a shield part one end grounding in principle. However, both-ends grounding or no grounding may be effective by the noise. Please choose the suitable grounding method according to environment.

Chapter 5 Control of EH-SIO

EH-SIO works based on the instructions from EH-CPU. The instructions of EH-CPU is made by user program. This chapter explains the command which controls EH-SIO, the register which display the status of EH-SIO, the register which controls EH-SIO.

5.1 EH-SIO Control command (TRNS 9)

5.1.1 Function of command

Control of EH-SIO is executed by transmission command "TRNS 9".

TRNS 9 is the command to send / receive the data between EH-CPU and EH-SIO. This data includes commands which controls EH-SIO, and a command. EH-SIO analyzes the command sent from EH-CPU, and executes operation according to the command.

5 fundamental functions of TRNS 9 command are shown below.

(1) Setting of EH-SIO

If TRNS 9 command (initial-setting command) is executed, the communication mode of EH-SIO will be set up.

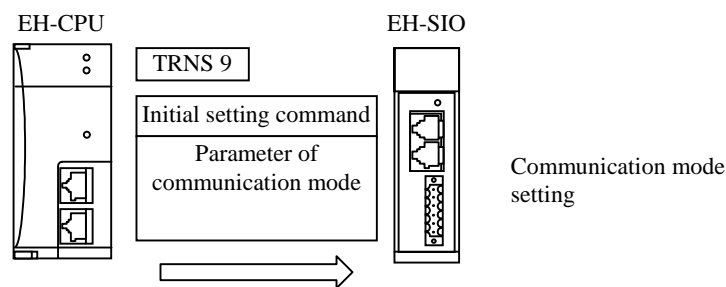

Figure.5.1 Operation of TRNS 9 (Initial setting)

(2) Data receiving from EH-SIO

If TRNS 9 command (Receive command) is executed, the data stored in the receiving buffer of EH-SIO is read to the receiving data area of EH-CPU.

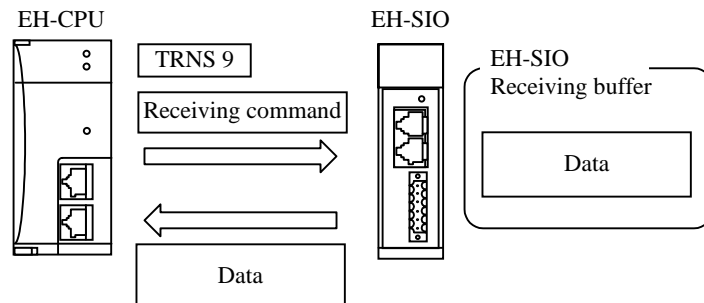

Figure 5.2 Operation of TRNS 9 (Receiving command)

(3) Data sending from EH-SIO (Send only)

If TRNS 9 command (Send command + Send data) is executed, data will be sent from EH-SIO.

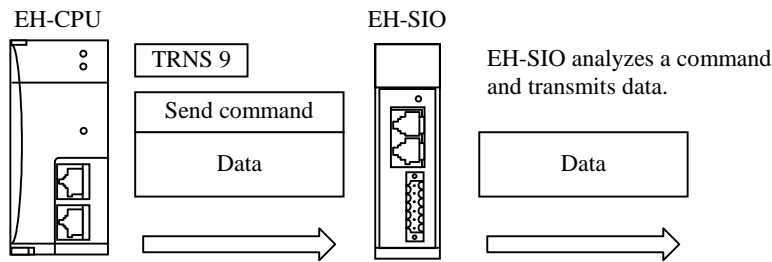

Figure 5.3 Operation of TRNS 9 (Send command)

(4) Data sending and receiving

If TRNS 9 command (Receives after sending command + send data) is executed, data will be sent from EH-SIO. Then the receiving data is stored in EH-CPU. (In this case, data sending and receiveing are operated by one command.)

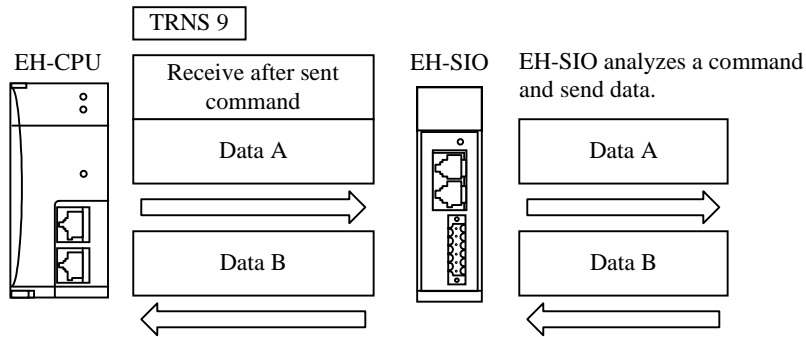

Figure 5.4 TRNS 9 Operation of TRNS 9 (Receive after sent command)

(5) Data receiving and sending

If TRNS 9 command (Send after receiving command + send data) is executed, EH-SIO waits to receive data from external device. After receiving, EH-SIO will send data. The received data is stored in EH-CPU. In this case, data receiveing and sending are operated by one command.)

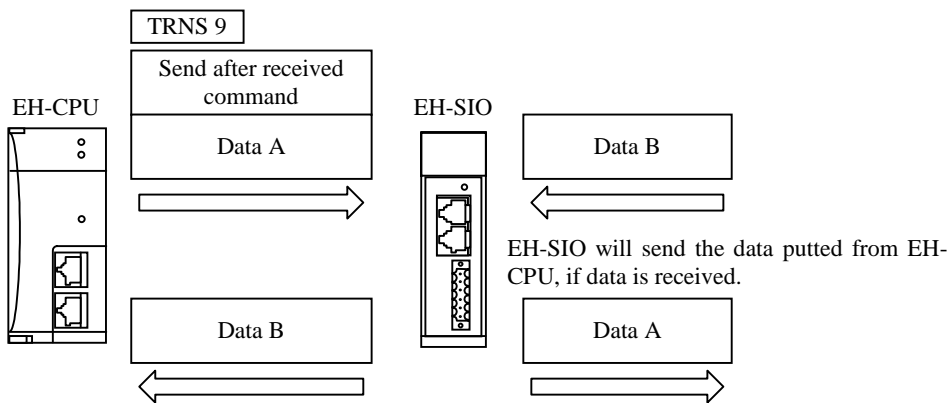

Figure 5.5 TRNS 9 Operation of TRNS 9 (Send after received command)

5.1.2 TRNS 9 Command format

TRNS 9 command consists of three parameters, d, s, and t.

And data table area (called send data area, receiving data area) are exist. Data table address to send and receive are configured in "s" parameter.

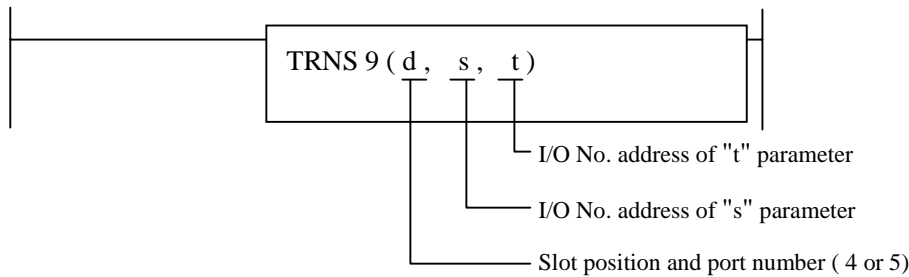
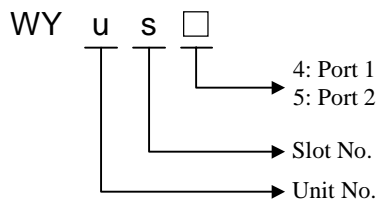

Figure 5.6 TRNS 9 Command format

■ d parameter

The slot position and port number are designated by this parameter



Ex.) In case of the port 2 of a basic unit (unit 0) and slot 3. → WY035

■ s parameter

The s parameter is used for 14 words in total. The configuration of s parameter is shown below.

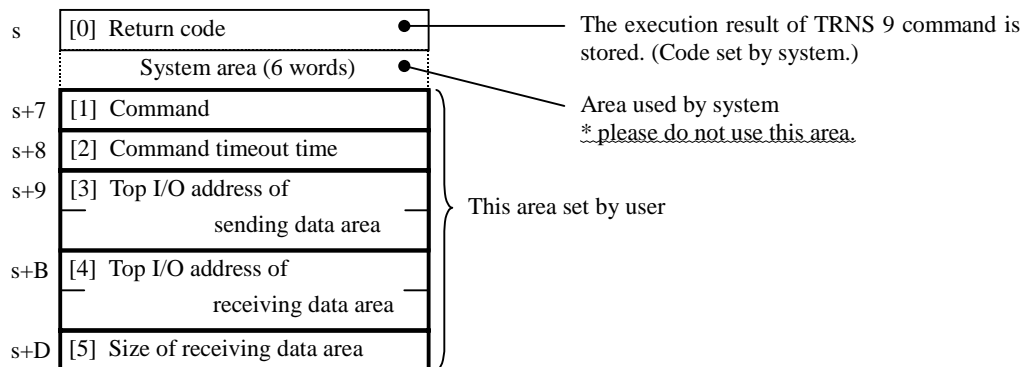

Figure 5.7 Configuration of s parameter (TRNS 9 command)

[0] Return code

When TRNS 9 command is executed, an execution result is stored in high byte, and the executed command is stored in low byte. The execution result code is set to H00 when TRNS 9 command is executed properly. About the code area at the time of abnormalities, please refer to the return code in "Chapter 6 communication mode".

Ex.) In case of executed ommand H21 → Normal completion : H0021

[1] Command

Set command according to operation.

Please refer to "Chapter 6 Communication mode."

[2] Command timeout time

Set the timeout time of TRNS 9 command.

- = H0000 : command timeout disable
- ≠ H0000 : command timeout eable. (Setting value x 10 ms)

If EH-SIO does not receive data within the configured time, TRNS 9 is cancelled as command timeout error.

Max. timeout time is 655,350 ms(HFFFF).

[3] Top I/O address of sending data area

Set the top I/O address of sending data area.

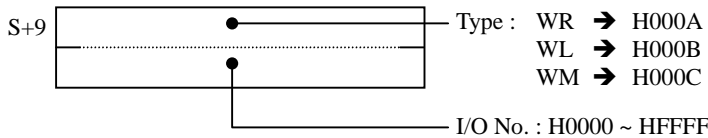

[4] Top I/O of receiving data area

Set the top I/O address of receiving data area.

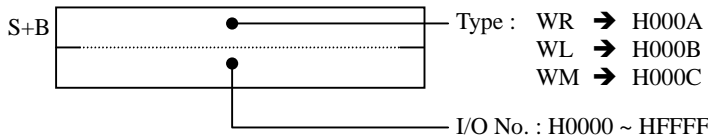

[5] Size of receiving data area

Set reserved size of receiving data area

Ex.) H000A → 10 words area reserved.

Reference : Two "timeouts"

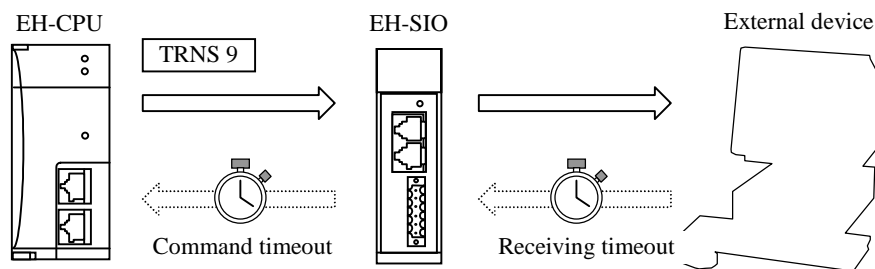

"Timeout" exists in TRNS 9 command and EH-SIO each other. The "command timeout" is for EH-CPU module configured in s parameter. The "receiving timeout" is for EH-SIO configured in initial setting. The purpose of each timeout is different.

If a command timeout error occurs, EH-CPU will close TRNS 9 command while EH-SIO is still working. In this case, EH-SIO does not receive the new command from EH-CPU. The command timeout time should be larger value than the receiving timeout time. (If command timeout error occurs, please initialize TRNS 9 command.)

■ t parameter

The t parameter is used 5 bits in all. The configuration of t parameter is shown below.

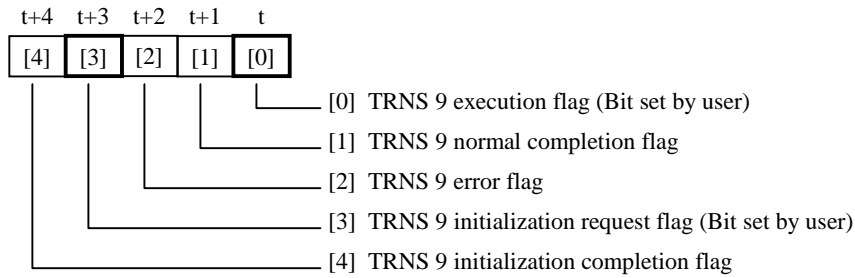

Figure 5.8 Configuration of t parameter (TRNS 9 command)

[0] TRNS 9 execution flag

When this bit is set to ON, TRNS 9 command is executed. (The command and data are sent to EH-SIO.) After TRNS 9 command is completed, it is set to OFF automatically.

[1] TRNS 9 normal completion flag

If TRNS 9 command is completed properly, this bit is set to ON. When the command execution flag (t+0) is set to ON, it is set to OFF automatically.

[2] TRNS 9 error flag

If TRNS 9 command is not completed properly, this error flag will be set to ON. When a command execution flag (t+0) is set to ON, it is set to OFF automatically.

[3] TRNS 9 initialization request

When this bit is set to ON, the status of the TRNS 9 command and a handshake with EH-SIO are returned to an initial state. Moreover, EH-SIO is returned to the state after initial setting completion. (All the packets that EH-SIO had received till then are also cleared.)

Please turn on, when a command timeout error occurs. If an initialization is completed, it is set to OFF automatically.

[4] TRNS 9 initialization completion

If the initialization of TRNS 9 command is completed, it is set to ON automatically. If a command execution flag (t+0) or a TRNS 9 initialization request (t+3) is set to ON, it is set to OFF automatically.

« Note »

- ◆ TRNS 9 command performs initialization of the internal work memory and so on at the first scan. Therefore, please do not turn on a TRNS 9 command execution flag with RUN after 1 scan.
- ◆ If two or more TRNS 9 commands are executed to the same communication port, TRNS 9 command will not perform properly. Please make a program so several execution flags not to be ON in parallel.
- ◆ Please do not set the area of s parameter and t parameter as power failure memory. Since former information remains next time at the time of power supply ON, TRNS9 may stop operating normally.

■ Sending data area

The configuration of sending data area is shown below.

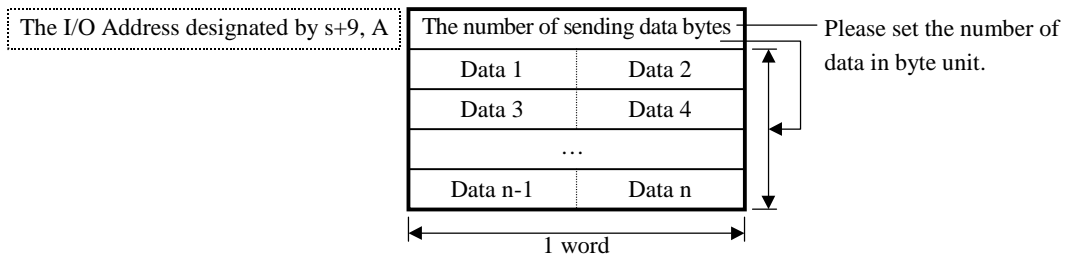

Execution of TRNS 9 command send the data of the designated number of bytes (Top address of sending data area) to EH-SIO. As for a data part, the purposes differ according to an execution command. Please refer to "Chapter 6 Communication mode" for details.

■ Receiving data area

The configuration of receiving data area is shown below.

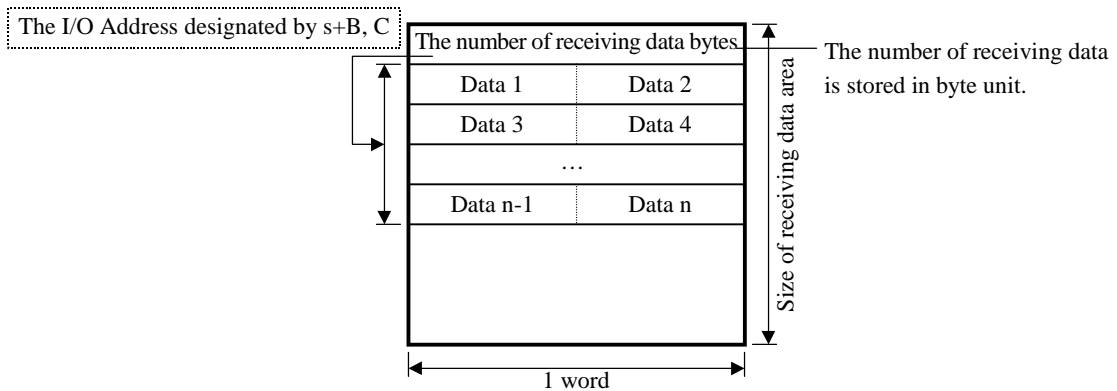

If data is receive from EH-SIO by TRNS 9 command, the receive data is stored in receiving data area. The number of bytes of the received data is stored in the top of receiving data area. The contents of received data depends on executed commnad. Please refer to "Chapter 6 Communication mode" for details.

« Note »

- ◆ When the received data is odd bytes, low byte of the last word is H00.
- ◆ When the received data exceeds receiving data area size, data within the size is stored, but the data beyond is omitted.

📖 Reference : The internal output used by TRNS 9

TRNS 9 seems to use only two internal output area, t and s, on a command format. However, there are sending data area and receiving data area designated with s parameter. Therefore, a total of four internal output area is required. It is necessary to create a program so that each area is not overlaped.

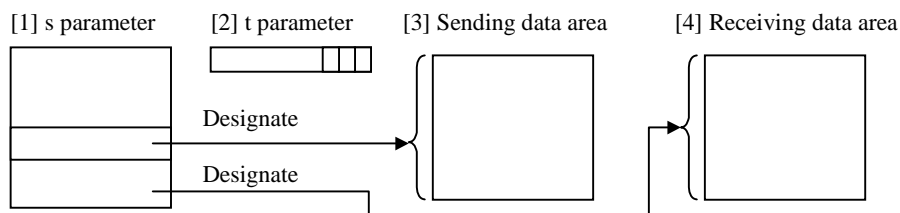

5.2 Input / Output register

By using an input / output register, the state of EH-SIO can be checked or EH-SIO can be reset* without using TRNS 9 command.

The input / output register is assigned to the I/O area (area of 4W/4W) of EH-SIO. The input register is in WXus0-WXus3, and especially WXus0 and 1 are called status register. The output register is in WYus4-WYus7, and especially WYus4 and 5 are called control register. The status register indicates the state of EH-SIO. The control register is used when sending instructions from EH-CPU to EH-SIO.

* It restricts, when the system of EH-SIO is operating normally. Reset by the hard switch is required at the time of serious failure occurred.

« Note »

Be careful of the treatment of the input / output register by the user program, or a set / reset.

- ♦ If the value of an input-and-output register is rewritten during TRNS 9 command execution, the status of the handshake of EH-CPU and EH-SIO may shift. The handshake once shifted does not return to normal, unless it carries out the initial of the TRNS 9 command.
- ♦ If initial setting is completed by EH-SIO at the time of Modbus slave mode, Hi-Protocol mode, and simple data link mode operation, a handshake will be started automatically (TRNS9 command is not executed.). If the value of an input-and-output register is rewritten during each mode operation, EH-SIO may stop operating. In this case, reset and initial setting of EH-SIO are needed.

Reference :

Exchanging data between EH-CPU and EH-SIO is automatically executed by TRNS 9 command. It is not always necessary to use input / output register for programming, except for controlling hand shake signals.

5.2.1 Register configuration

The function of the input / output register is shown below.

Table 5.1 Function of Input / Output register

Word No	Direction	Function
WX u s 0	EH-CPU ← EH-SIO (CPU Read)	Status register for port 1 The data about the state of a port 1 is set.
WX u s 1	EH-CPU ← EH-SIO (CPU Read)	Status register for port 2 The data about the state of a port 2 is set.
WX u s 2	EH-CPU ← EH-SIO (CPU Read)	System area for port 1 Before initial setting : Used by system In free protocol mode : Number of receive packet In dedicated procedure mode : Error code In Simple data link mode : Used by system <u>Note : An error code is indicated when serious failure occurs in the system of EH-SIO.</u>
WX u s 3	EH-CPU ← EH-SIO (CPU Read)	System area for port 2 Before initial setting : Software version In free protocol mode : Number of receive packet In dedicated procedure mode : Error code In Simple data link mode : Error code
WY u s 4	EH-CPU → EH-SIO (CPU Write)	Control register for port 1 The data for EH-CPU controlling a port 1 is set. Set by EH-CPU or user.
WY u s 5	EH-CPU → EH-SIO (CPU Write)	Control register for port 2 The data for EH-CPU controlling a port 2 is set. Set by EH-CPU or user.
WY u s 6	EH-CPU → EH-SIO (CPU Write)	System area for port 1 <u>Note: Please do not write. It is used by EH-CPU</u>
WY u s 7	EH-CPU → EH-SIO (CPU Write)	System area for port 2 <u>Note: Please do not write. It is used by EH-CPU</u>

u : Unit No. (0 to 4)

s : Slot No. (0 to 7)

0 ~ 7 : Word No. which EH-SIO occupies

*Dedicated procedure ... Modbus slave mode, Hi-Protocol mode

5.2.2 Detail of input register

■ Configuration of status register

The status register consists of 16 bits. A meaning is different for each bit.

		WXrus0															
Bit		15	14	13	12	11	10	9	8	7	6	5	4	3	2	1	0
Abbreviation		XCNT1	XHS1	XIC1	--	--	XMDE	XCDE1	XDTE1	CD1	CS1	DR1	--	TII1	PTE1	OBE1	IBE1

		WXrus1															
Bit		31	30	29	28	27	26	25	24	23	22	21	20	19	18	17	16
Abbreviation		XCNT2	XHS2	XIC2	--	--	XMDE	XCDE2	XDTE2	CD2	CS2	DR2	IFS	TII2	PTE2	OBE2	IBE2

Figure 5.9 Configuration of status register

Table 5.2 Contents of status register

Bit	Abbreviation	Name	Contents of each flag
15	XCNT1	X-CoNTinue flag	It is set to "1" while having transmitted the data of a port 1 to CPU.
14	XHS1	X-HandShake flag	It is set to "1" when ready for sending the data of a port 1 to CPU.
13	XIC1	X-Initial Complete flag	It is set to "1" if initial setting of a port 1 is completed.
12	--		Undefined, always "0".
11	--		Undefined, always "0".
10	XMDE	X-ModuleError flag	It is set to "1" when a serious failure error occurs in EH-SIO.
9	XCDE1	X-CommanD Error flag	It is set to "1" when the error of a warning level occurs in a port 1.
8	XDTE1	X-DaTa Error flag	It is set to "1" when an error occurs to the transmission data in the port 1.
7	CD1	Port1 CD signal status	The state of CD signal of a port 1. It is set to "1" at the time of High.
6	CS1	Port1 CS signal status	The state of CS signal of a port 1. It is set to "1" at the time of High.
5	DR1	Port1 DR signal status	The state of DR signal of a port 1. It is set to "1" at the time of High.
4	--		Undefined, always "0".
3	TII1	Port1 Trns Instruction Invalid	It is set to "1" when a port 1 is in the state of the TRNS command non-effect (setup the dedicated procedure mode* ¹).
2	PTE1	Port1 Error	It is set to "1" when a port 1 has an error.
1	OBE1	Out Buffer 1 Empty	It is set to "1" when the send buffer for port 1 is empty.
0	IBE1	In Buffer 1 Exist	It is set to "1" when data is in the receive buffer for port 1.

Bit	Abbreviation	Name	Contents of each flag
31	XCNT2	X-CoNTinue flag	It is set to "1" while having transmitted the data of a port 2 to CPU.
30	XHS2	X-HandShake flag	It is set to "1" when ready for sending the data of a port 2 to CPU.
29	XIC2	X-Initial Complete flag	It is set to "1" if initial setting of a port 2 is completed.
28	--		Undefined, always "0".
27	--		Undefined, always "0".
26	XMDE	X-ModuleError flag	It is set to "1" when a serious failure error occurs in EH-SIO.
25	XCDE2	X-CommanD Error flag	It is set to "1" when the error of a warning level occurs in a port 2.
24	XDTE2	X-DaTa Error flag	It is set to "1" when an error occurs to the transmission data in the port 2.
23	CD2* ²	port2 CD signal status	The state of CD signal of a port 2. It is set to "1" at the time of High.
22	CS2* ²	port2 CS signal status	The state of CS signal of a port 2. It is set to "1" at the time of High.
21	DR2* ²	port2 DR signal status	The state of DR signal of a port 2. It is set to "1" at the time of High.
20	IFS	InterFace Select	The communication I/F of Port2. It is set to "1" at the time of RS-422/485. It is set to "0" at the time of RS-232C.
19	TII2	port2 Trns Instruction Invalid	It is set to "1" when a port 2 is in the state of the TRNS command non-effect (setup the dedicated procedure mode * ¹).
18	PTE2	Port2 Error	It is set to "1" when a port 2 has an error.
17	OBE2	Out Buffer 2 Empty	It is set to "1" when the send buffer for port 2 is empty.
16	IBE2	In Buffer 2 Exist	It is set to "1" when data is in the receive buffer for port 2.

*1 Modbus slave mode, Hi-Protocol mode, Simple data link mode

*2 When RS-422 and 485 are used for communication I/F of a port 2, undefined. (always "1")

Please refer to "7.2 Error indication" about the details of error flags (XMDE, XCDE, XDTE, and PTE).

■ Contents of system area

The system area of the input register consists of 1 word per port. The contents depends on operation mode (communication mode). In addition, when serious failure (except for a WDT error) occurs during operation, The serious failure error code is indicated in the system area for port 1 regardless of operation mode.

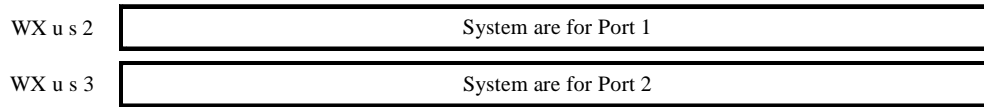

Figure 5.10 System area of input register

Table 5.3 Contents of system area (Port1, 2 common)

No.	Status of communication port	Contents of display
1	Before initial setting	Software version
2	Free protocol mode	The number of effective packets of the data received in the port* ¹
3	Modbus master mode	Not used (H0000 fixed)
4	Modbus slave mode	The newest error code* ²
5	Hi-Protocol mode	The newest error code* ³
6	Simple data link mode	The newest error code* ⁴

*1 The number of the data which EH-SIO made one packet. However, when an error occurs to receiving data, error information is also treated as one packet.

*2 Error code at receiving query. If the next query is received properly, the error code is cleared.

*3 The contents of an error occurred at the time of request task code reception are displayed. An error will be cleared if the task code which received after that is processed normally. (It is set to H0000.)

*4 WXus2 is H0000 fixation. The contents of an error occurred at the time of the data link are displayed on WXus3. Restoration of the data link clears an error. (It is set to H0000.)

5.2.3 Detail of output register

■ Configuration of control register

The control register consists of 16 bits. A meaning is different for each bit.

		WYrus4															
Bit		79	78	77	76	75	74	73	72	71	70	69	68	67	66	65	64
Abbreviation		YCNT1	YHS1	YCV1	--	PRST1	--	RS1	ER1	System area							

		WYrus5															
Bit		95	94	93	92	91	90	89	88	87	86	85	84	83	82	81	80
Abbreviation		YCNT2	YHS2	YCV2	--	PRST2	--	RS2	ER2	System area							

Figure 5.11 Configuration of control register

Table 5.4 Contents of control register

Bit	Abbreviation	Name	Contents of each flag
79	YCNT1	Y-CoNTinue flag	It is set to "1" when there is a continuation of the data sent to EH-SIO (port 1) from CPU.
78	YHS1	Y-HandShake flag	It is set to "1" when sending data to EH-SIO (port 1) from CPU.
77	YCV1	Y-Command Valid flag	It is set to "1" when the command to a port 1 is decided.
76	--		Used by system.
75	PRST1	Port1 ReSeT	Please set 1, when you return the state of a port 1 to the state at the time of a power supply ON (before initial setting completion). It resets by the system.
74	--		Undefined.
73	RS1*	port1 RS signal control	RS signal of a port 1 is controllable at the time of free protocol mode / modem control enable. RS signal will be set to High if 1 is set.
72	ER1*	port1 ER signal control	ER signal of a port 1 is controllable at the time of free protocol mode / modem control enable. ER signal will be set to High if 1 is set.
71 to 64	--	System Area	Used by system.

Bit	Abbreviation	Name	Contents of each flag
95	YCNT2	Y-CoNTinue flag	It is set to "1" when there is a continuation of the data sent to EH-SIO (port 2) from CPU.
94	YHS2	Y-HandShake flag	It is set to "1" when sending data to EH-SIO (port 2) from CPU.
93	YCV2	Y-Command Valid flag	It is set to "1" when the command to a port 2 is decided.
92	--		Used by system.
91	PRST2	Port2 ReSet	Please set 1, when you return the state of a port 2 to the state at the time of a power supply ON (before initial setting completion). It resets by the system.
90	--		Undefined.
89	RS2*	port2 RS signal control	RS signal of a port 2 is controllable at the time of free protocol mode / modem control enable. RS signal will be set to High if 1 is set.
88	ER2*	port2 ER signal control	ER signal of a port 2 is controllable at the time of free protocol mode / modem control enable. ER signal will be set to High if 1 is set.
87 to 80	--	System Area	Used by system

* In case of the initial setting completion before or the setup of control signal non-effect, it is ignored even if it turns on this bit. Moreover, this bit is not used when using RS-422 and 485 for communication I/F of a port 2.

« Note »

- ◆ Only "PRST" , "RS", and "ER" of a control register can be operated by user.

The other bits and other system area (WYus6 and WYus7) are used by the system, please do not write those area, otherwise EH-SIO does not work properly.

- ◆ When EH-SIO has stopped by serious failure, reset by the PRST flag cannot be performed.
- ◆ When EH-SIO is reset with a PRST flag, please initialize EH-SIO (an initialization request flag is turned on) by TRNS 9 command.

Chapter 6 Communication Mode

For EH-SIO, after the initial setting is complete, the communication procedure is then decided. This communication procedure is called the communication mode. EH-SIO has two communication ports which are operated independently, therefore a different communication mode can be assigned to each communication port.

This chapter explains the details of each communication mode. Please create a communication program after carefully reading this chapter and "Chapter 5 Control of EH-SIO."

6.1 Introduction

This paragraph explains the basic operation of EH-SIO. Please refer to the next paragraph for a detailed explanation of the communication mode.

■ Basic operation of EH-SIO

Operation of EH-SIO is shown in the following figure.

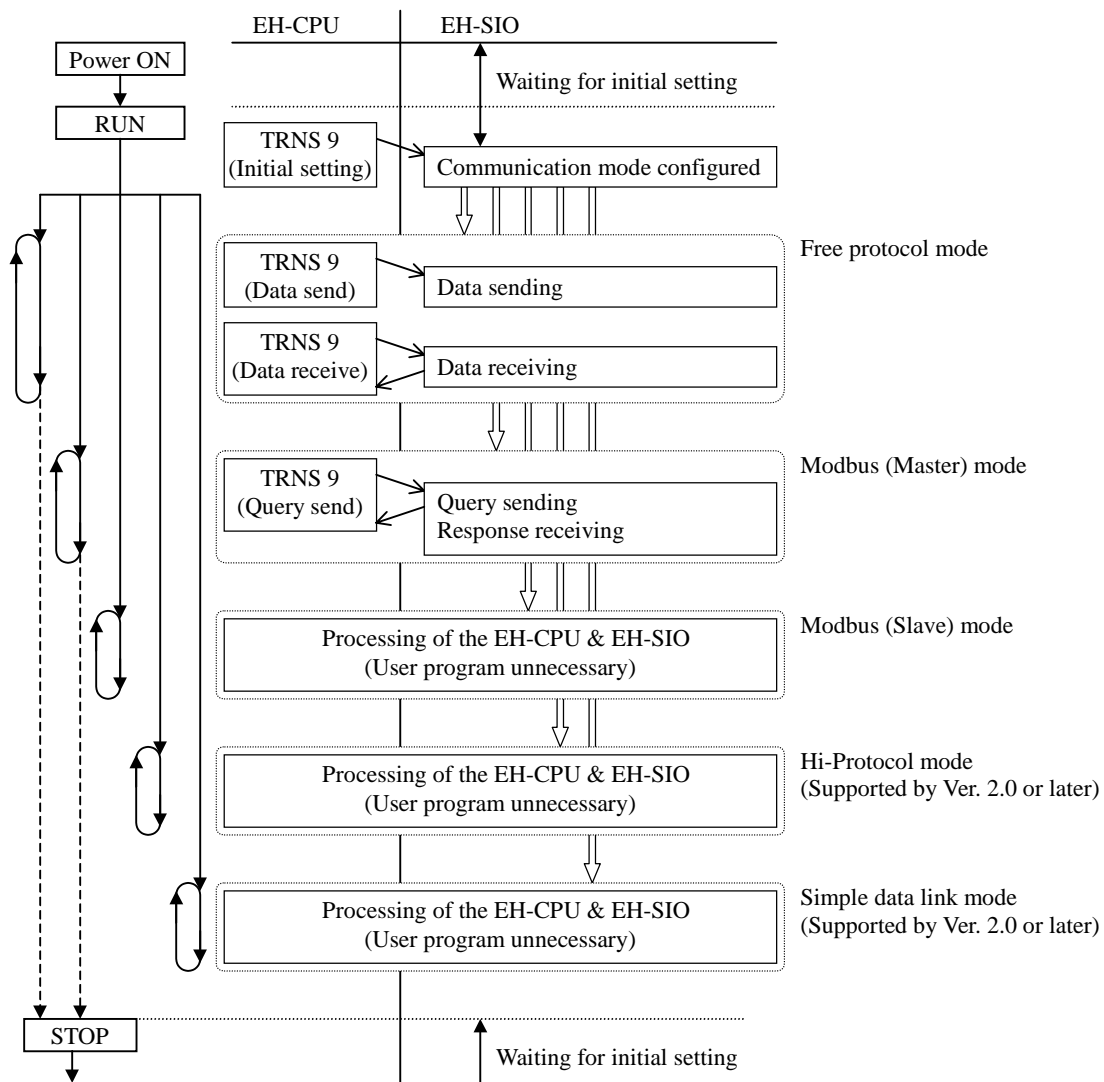

Figure 6.1 Basic operation of EH-SIO

EH-SIO will not communicate until initial setting is completed. After the initial setting is completed, the operation will start according to the setting.

When the communication mode is set for free protocol mode or modbus master mode, communication is controlled by TRNS 9 command. In the case of modbus slave mode and Hi-Protocol mode, a system performs automatically from the watch of a request to response transmission. In the case of simple data link mode, the I/O information of data link area is automatically updated by the system.

In addition, in case of modbus slave mode, Hi-Protocol mode, simple data link mode, operation works even if EH-CPU is in stop. (Please reset EH-SIO, in order to cancel the setup.)

6.2 Free protocol mode

In free protocol mode, EH-SIO works according to the command transmitted from EH-CPU. There are three types of commands: initial setting, data receive, and data send.

6.2.1 Overview

■ Data Receiving

EH-SIO will start data receiving by the system, after initial setting is completed. The received data is divided according to the message composition registered in the initial setting, and is stored in a receiving buffer. (In this book, each data division is referred to as a “packet”.)

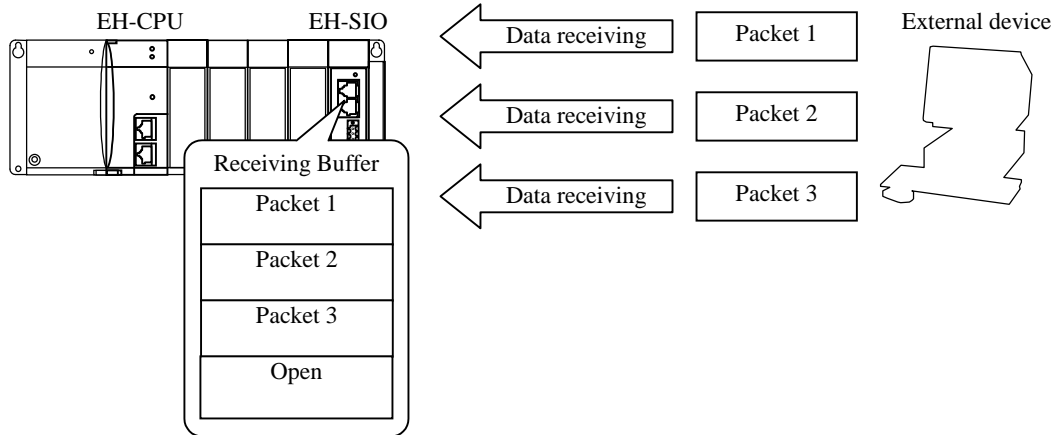

Figure 6.2 Structure of data reception 1

When EH-SIO receives one or more packets in a receiving buffer, the indication of receiving packet in input register will be added. If EH-CPU execute TRNS 9 (data read command) in this state, EH-SIO will send the oldest packet from a receiving buffer to EH-CPU, and this area in receiving buffer is left as empty.

In addition, only one packet can be passed per the data read command. In order to have all packets sent to EH-CPU, TRNS 9 (read command) must be performed until the receiving buffer is clear.

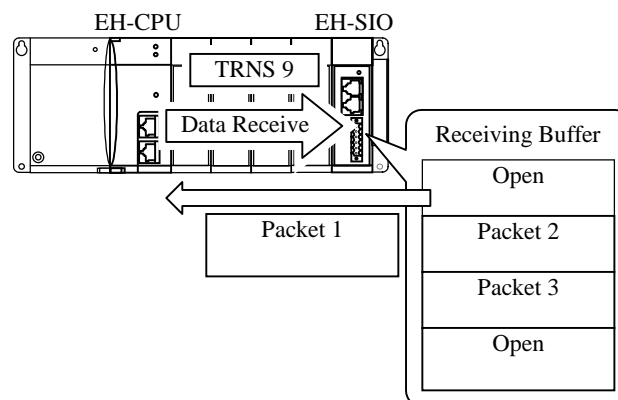

Figure 6.3 Structure of data reception 2

■ Sending data

EH-SIO send a packet to external device, shortly after receiving the packet transmitted by TRNS 9 (data sending command) from EH-CPU. If Message composition is registered at initial setting, EH-SIO will process a sending packet automatically and will send it.

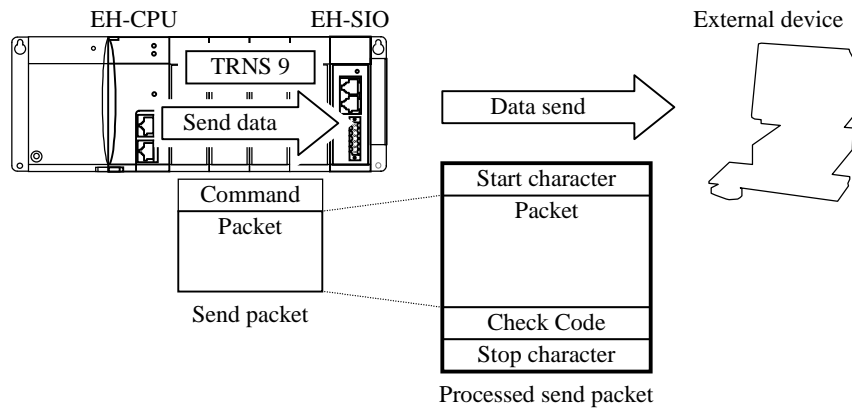

Figure 6.4 Structure of data transmitting

< Variation of data transmission >

There are three methods of data send: sending only, receives after sending, send after receiving.

■ Error detection

EH-SIO is able to detect errors in the hardware and can check receiving data. When error of hardware (ROM error, RAM error, WDT error, etc.) are detected, error information is shown on the LED display, and operation stops. When error in receiving data (parity error, framing error, etc.) are detected, error information is shown on the LED display, and the information is stored in a receiving buffer as one packet. When the packet of error information is read, the error code is stored in a return code area. In addition, the errors of receiving data are classified into "Warning", and EH-SIO continues operation.

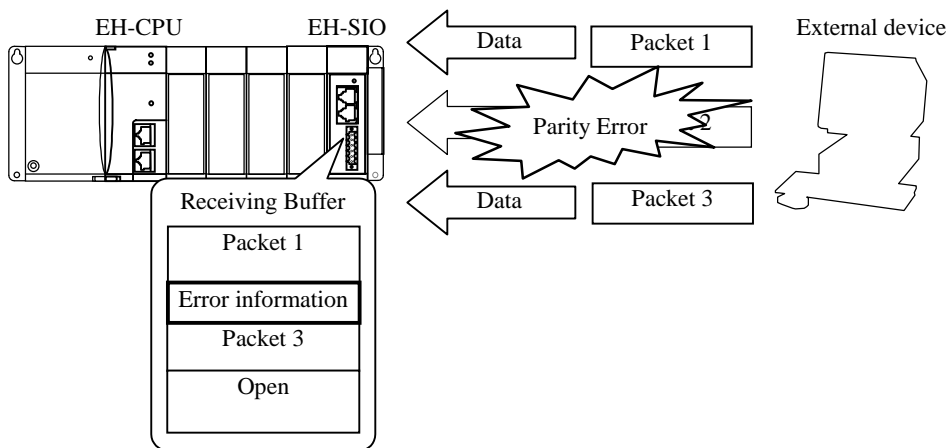

Figure 6.5 Detection of warning (receiving error)

6.2.2 User project structure

Following user project structure is required in case of usage of free protocol mode of EH-SIO.

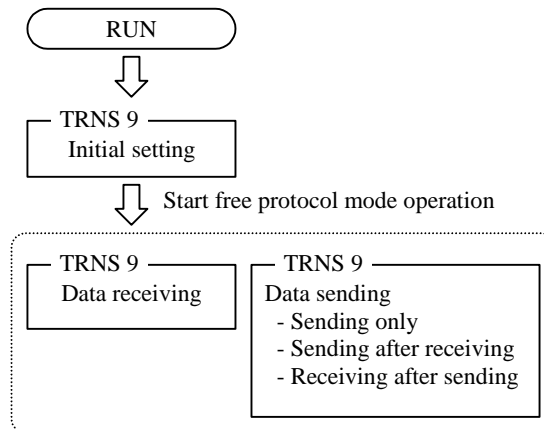

Figure.6.6 User project structure (Free protocol)

[STEP 1]

To configure communication port of EH-SIO as free protocol mode by using TRNS9 command.

[STEP 2]

"Data reception" and "Data transmission" are performed according to the devices to connect.

Regarding initial setting, data reception and data sending detailed, explanation are shown in subsequent paragraphs.

6.2.3 Initial setting

When the power is turned on, the EH-SIO will be in idling state (waiting for initial setting from EH-CPU). After the initial setting from the EH-CPU, operation in free protocol mode begins. Once initial setting is completed, the setup cannot be changed unless EH-CPU is stopped or EH-SIO is reset.

« Note »

When there is no initial setting, EH-SIO will not receive any other data from EH-CPU and external device than initializing command.

■ Parameters required for initial setting

Table 6.1 Parameter table for initialization

No.	Parameter	Contents
1	Communication mode (Indispensable)	Operation after initial setting depends on chosen communication modes of EH-SIO. Please specify the parameter corresponding to free protocol mode.
2	Message composition (Indispensable)	Configuration of the data sent and received. There are ten types of combinations. Please specify the parameter corresponding to the message composition to be used. If message composition is registered, a start character, stop character, and check code will be automatically added or deleted by EH-SIO.
	Modem line control (Indispensable)	When RS-232C port is connected with a modem and communicating, the state of a control signal (RS, ER) can be switched by the user program. Also, as the control signal can be turned on, please choose according to use. * For RS-422/485 port, this setup cannot be used.
	Data conversion type (Indispensable)	EH-SIO has a function which changes the character transmitted from EH-CPU and sent it, and a function which changes the character of receiving data and passes it to EH-CPU. The following are the three types of conversion types supported: 1) EH-CPU ⇔ EH-SIO Through (no change) 2) EH-CPU(Binary) ⇔ EH-SIO(ASCII) Binary ⇔ ASCII Conversion 3) EH-CPU(Binary) ⇔ EH-SIO(Binary) Binary through
3	Start character (Optional)	When the message composition has a start character, a start character (max. 2 byte) is recommended to be specified. Only one type of start character can be registered.
4	Stop character (Optional)	When the message composition has a stop character, a stop character (max. 2 byte) is recommended to be specified. Only one type of stop character can be registered.
5	Check code calculation type (Optional)	When the Message composition has check codes (BCC, sum, etc.), the calculation type of a check code is recommended to be specified. When the check code by the calculation type which is not supported by EH-SIO is required, please choose message composition without a check code and calculate by the user program.
6	Receiving timeout (Optional)	When timeout is specified, EH-SIO will receive timeout error in the following cases: 1) When there is no response from external device after specified time passes. 2) When data receiving is not completed within the specified time. Please set this parameter to check for receiving a timeout by EH-SIO in the case of reception after sent.
7	Data interval time (Optional)	When performing data reception without specification of a stop character, EH-SIO detects the end of data by the time of no data. This period is called the data interval. When the end of the message composition does not have a stop character, this parameter needs to be set. (If not specified, 100ms is the default.)

■ s parameter of initial setting

Initializing command (specified as s+7) is H0000. Although nothing is stored in the receiving data area specified by s+B-s+D upon the performance of the initial setting command, please set during parameters in s+B to s+D.

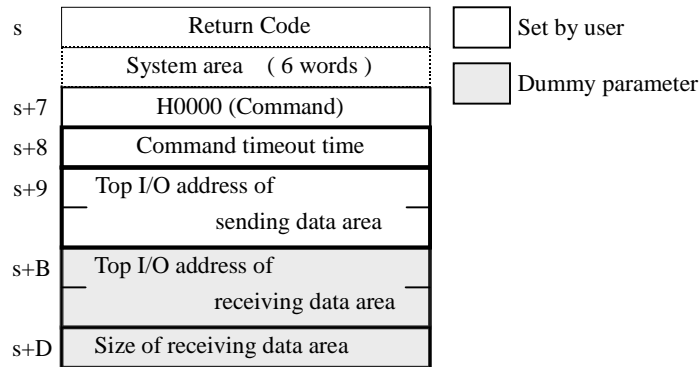

Figure 6.7 s parameter format (Free protocol / Initial setting)

■ Sending data area of initial setting

The sending data area parameter composition (the top I/O address is specified in s+9 and s+A) is as follows:

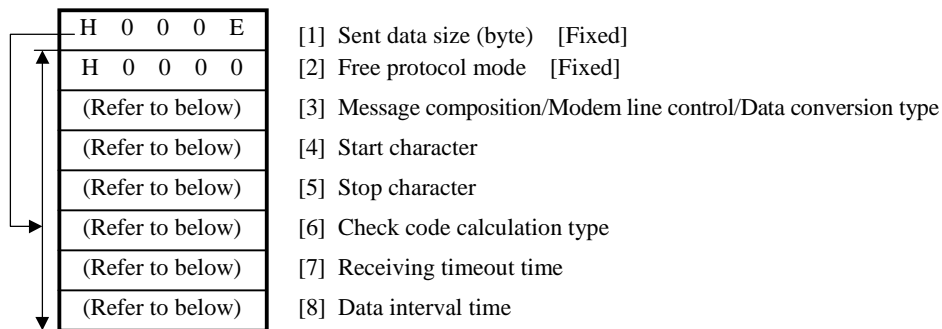

Figure 6.8 Sending data area format (Free protocol / initial setting)

The meaning and setting value of each parameter are shown below.

[1] Sent data size (byte)

The number of bytes of the data sent to EH-SIO is specified. Since the setting parameter is fixed to seven words, the number of transmission data bytes should be set to 14 bytes (14 / H000E).

[2] Communication mode specification

When you using free protocol mode, please set to H0000.

[3] Message composition / Control of modem line / Data conversion type

1 word

(1)	(2)	(3)
-----	-----	-----

(1) Message composition

Specify message format as below. If message composition is registered, EH-SIO will handle sending / receiving data automatically according to the setting.

Table 6.2 Registration message composition list

No.	Setup Value	Message composition
1	H00xx	Data only
2	H01xx	Data + Stop character
3	H02xx	Data + Check code * ¹
4	H03xx	Data + Check code + Stop character * ²
5	H04xx	Data + Stop character + Check code
6	H10xx	Start character + Data
7	H11xx	Start character + Data + Stop character
8	H12xx	Start character + Data + Check code * ¹
9	H13xx	Start character + Data + Check code * ¹ + Stop character
10	H14xx	Start character + Data + Stop character + Check code * ²
-	Others	Initial setting error

*1 Check code is calculated for a data part.

*2 Check code is calculated for a data part and a stop character part.

When a start character is not specified, EH-SIO will start receiving by any data. When a stop character is not specified, EH-SIO will stop receiving by interval time.

Reference : Message composition

If message composition is registered, only data part is handled by user program. The message composition of start character (STX) + data + check code + stop character (CR) is explained with the example below.

Data sending:

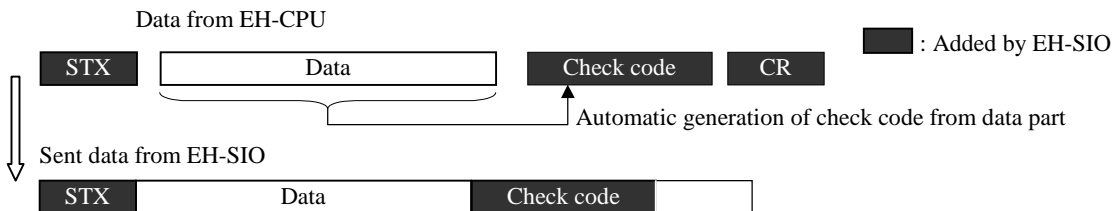

Data receiving:

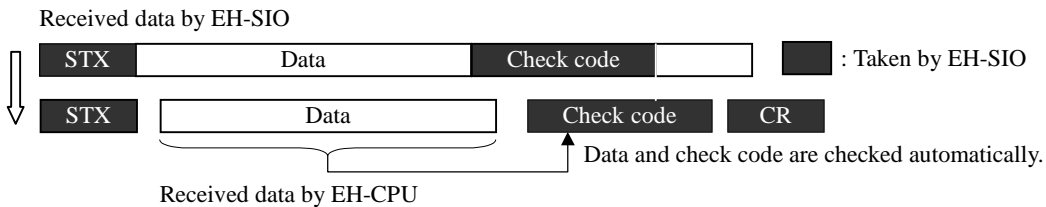

As shown in the above figure, the other part than data is handled by EH-SIO.

(2) Control of modem line

Specify whether the state of the control signal (RS, ER) is always set to high or switched by user program.

Table 6.3 Control list of registration modem lines

No.	Set value	Control of modem line
1	Hxx0x	RS, ER always high
2	Hxx1x	RS, ER follows the state of RS and ER flag of control register.
-	Others	Initial setting error

This setting is effective only when using the RS-232C port. When using port 2 with RS-422/485, so please set "0".

Regardless of the above setting, RS and ER will be turned off automatically when an error occurs in EH-SIO and receiving buffer is full.

(3) Data conversion type specification

EH-SIO has data conversion function. Specify the conversion type as below.

Table 6.4 Registration data conversion type list

No.	Set Value	Data conversion type
1	Hxxx0	Through (no conversion)
2	Hxxx1	Binary / ASCII conversion (EH-CPU / Binary ⇔ EH-SIO / ASCII)
3	Hxxx2	Binary through (EH-CPU / Binary ⇔ EH-SIO / Binary)
-	Others	Initial setting error

Through type (no conversion) :

The data stored in sending data area are transmitted as is, and the received data are stored in receiving data area as is.

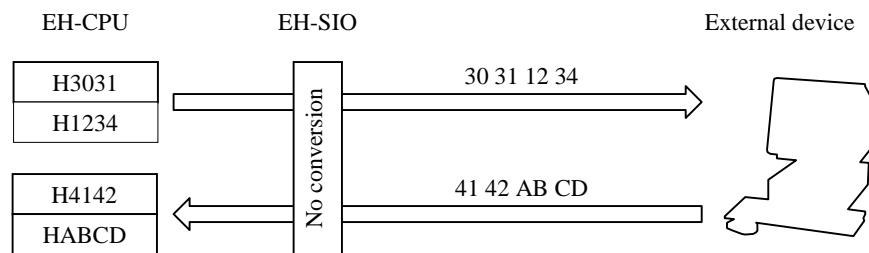

Figure 6.9 Example of through type (no conversion)

« Note »

- ◆ Caution is necessary when using a message composition with start/stop characters since those parts will be considered as starting and stopping points.
- ◆ When using 7-bit transmission code configuration, the data of H80-HFF cannot be transmitted and received correctly.

Binary ⇔ASCII conversion type :

The data stored in sending data area are changed into an ASCII code and transmitted, and the received data are changed into binary data and stored in receiving data area.

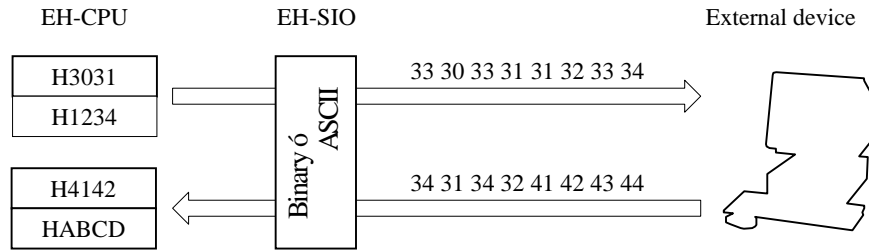

Figure 6.10 Example of Binary ⇔ ASCII conversion type

- ◆ The A-F EH-CPU data are changed into capital letter of ASCII code.
- ◆ When there is an ASCII code outside 0-9 / A-F in received message, the ASCII code error will be detected.

« Note »

EH-SIO is not able to send / receive odd number of byte data (in Binary ⇔ASCII conversion type).

Binary Through type :

The binary data stored in sending data area are transmitted, and the received binary data are stored in the receiving data area. This conversion type uses DLE (0x10) for discernment of a control code (a start character and stop character). Upon transmission, DLE is added in front of control code and 0x10 data and transmitted. Then, upon data reception, DLE is removed from received data and passed to EH-CPU.

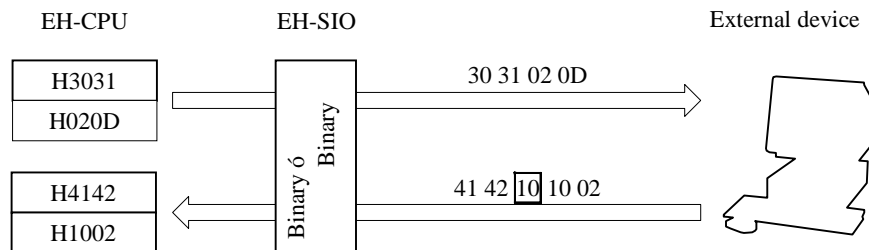

Figure 6.11 Example of Binary Through Type

Ex.) Start character STX(0x02), Stop character CR(0x0D), when data part is 40302010

➔ The data are actually transmitted as 10024030201010100D in a circuit.

In addition, when including a check code in message composition, a check code is calculated except for discernment DLE.

« Note »

EH-SIO is not able to send / receive odd number of byte data (in Binary through type).

[4] Start character

When message composition has a start character, start character is recommended to be specified. Start character can be registered 2 bytes max.

Case of one byte : Be sure to specify a start character in high byte, and a low byte must be HFF. Effective ranges are H00-HFE. However, H10 cannot be used when a binary through type is chosen at [3]. If a character that cannot be used is registered, it will become an initial setting error.

Ex.) Start character is “STX” → H02FF

Case of 2 bytes : Specify the start character with one word.

Effective range is H0000 to HFFFE. However, a character that uses the same code twice cannot be used. Moreover, when a binary through type is chosen at [3], the character (H10xx and Hxx10) containing H10 cannot be used. If a character that cannot be used is registered, it will become an initial setting error.

[5] Stop character

When message composition has a stop character, a stop character is recommended to be specified. Stop character can be registered 2 bytes max.

Case of one byte : Be sure to specify a stop character in high byte, and a low byte must be HFF. Effective ranges are H00-HFE. The effective range is same as start character.

Ex.) Stop character is “CR” → H0DFF

Case of 2 bytes : Specify the start character with one word.

The effective range is same as start character.

Ex.) Stop character is “CR+LF” → H0D0A

[6] Check code calculation type

EH-SIO corresponds to various types of check codes. When using the message composition containing a check code, please choose the calculation type from Table 6.5. If a check code is registered, EH-SIO will perform generation and collation automatically for the data transmitted and received.

Table 6.5 Check code calculation type list

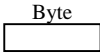
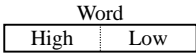
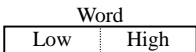
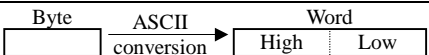
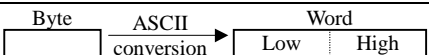
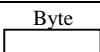
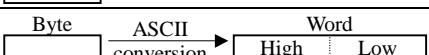
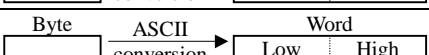
No.	Set Value	Formula	Calculation result
1	H0000	$(B1) + (B2) + \dots + (Bn)$	Calculates by binary 
2	H0001	$(B1) + (B2) + \dots + (Bn)$	Calculates by binary 
3	H0002	$(B1) + (B2) + \dots + (Bn)$	Calculates by binary 
4	H0003	$(B1) + (B2) + \dots + (Bn)$	Calculates by binary 
5	H0004	$(B1) + (B2) + \dots + (Bn)$	Calculates by binary 
6	H0010	$\{(B1) \text{ xor } (B2)\} \text{ xor } \dots \text{ xor } (Bn)$	Calculates by binary 
7	H0011	$\{(B1) \text{ xor } (B2)\} \text{ xor } \dots \text{ xor } (Bn)$	Calculates by binary 
8	H0012	$\{(B1) \text{ xor } (B2)\} \text{ xor } \dots \text{ xor } (Bn)$	Calculates by binary 
-	Others	Initial setting error	

« Note »

- ◆ Check codes not found in Table 6.5 are not supported. In this case, please choose message composition without a check code and make ladder program to handle check code.
- ◆ When the calculation type, which makes binary data a check code as is, is used, please make it an 8-bit transmission code configuration.

[7] Receiving timeout

Receiving timeout is defined as time between the end of sent data and the end of received data.

= H0000 → Timeout disabled.

≠ H0000 → Timeout enabled in setting time x 10ms. The maximum timeout is HFFFF.

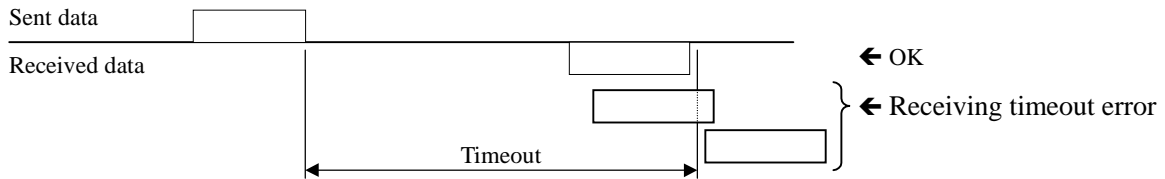

Figure 6.12 Monitoring of receiving timeout

[8] Data interval time

Data interval time is the time for determining the end of data, when a stop character is not contained in message composition. The end of data reception is determined when data are not received with the set data interval time. The timeout in characters is shown in Figure 6.13.

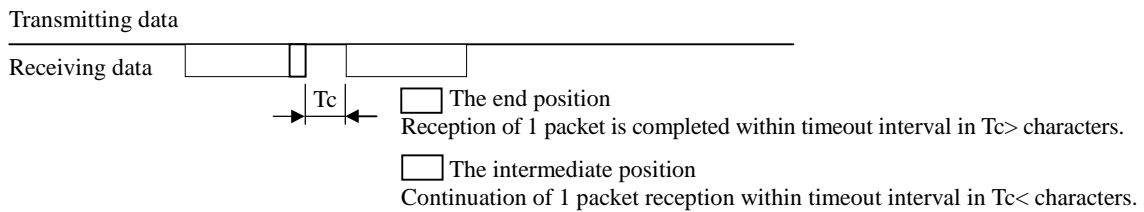

Figure 6.13 Timeout in characters

= H0000 → 100 ms fixed.

≠ H0000 → When there is x10ms data interval, it is recognized as the end of data. The maximum timeout is HFFFF.

« Note »

Please set the data interval time shorter than the [7] receiving timeout.

■ Execution of initial setting

After the required s parameter and parameter for send data are stored, please turn on the command execution flag (t+0).

■ End of initial setting

(1) Completed properly

H0000 is stored in return code area (s+0), and completion flag (t+1) goes on. A status register XICx goes on and LNK, MBx, HPx, and MSx on the LED will be off.

(x-1: Port 1, 2: Port 2)

(2) Error

Error flag (t+2) goes on, and error code will be stored in return code area. Please eliminate the error factor by referring to the return code in Section “6.2.7 Error detection in free protocol mode”.

■ Sample program [Initial setting]

(1) Ladder program

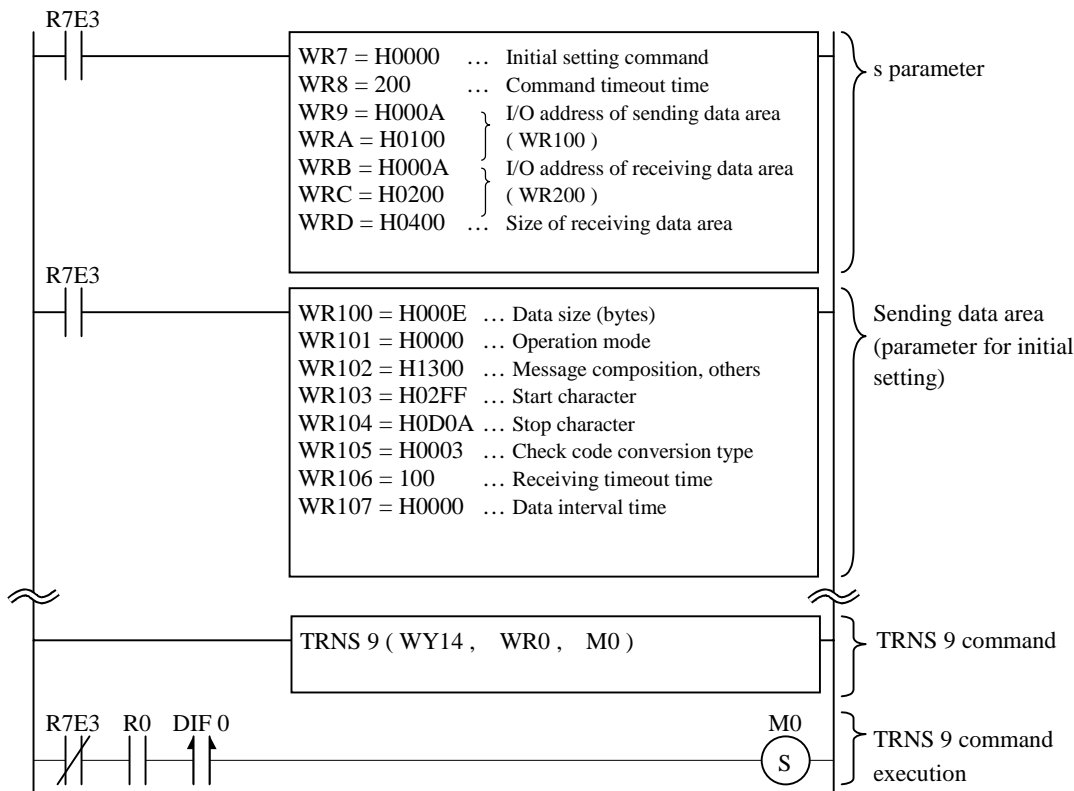

(2) Sample program description

The s parameter and the sending data area parameter are set upon first scan.

When R0 is on, TRNS 9 will be performed, and initial settings for basic unit (unit 0) and port 1 of slot 1 are shown in the following table.

Items	Setup value	Setup contents
Communication mode	H0000	Free protocol mode
Message composition	H13xx	Start character + data + check code + stop character
Modem line control	Hxx0x	RS, ER regular ON
Data conversion type	Hxxx0	Through type
Start character	H02FF	STX (02)
Stop character	H0D0A	CR/LF (0D0A)
Check code calculation type	H0003	Byte, ASCII, Sum
Receiving timeout interval	100	1000 ms
Data interval time	-	Disabled because of stop code used

« Note »

TRNS 9 is initialized at the 1st scan. So other settings and operations should be executed after the 2nd scan.

6.2.4 Communication start

After initial setting is completed, EH-SIO will be waiting for data. Data will be transmitted when a transmitting command is transmitted from EH-CPU. However, since the monitoring of the control signal is performed when communication port is using RS-232C, data are not received unless "DR" and "CS" of EH-SIO are selected. The flow chart up to the beginning of communication when RS-232C I/F is in use is shown below.

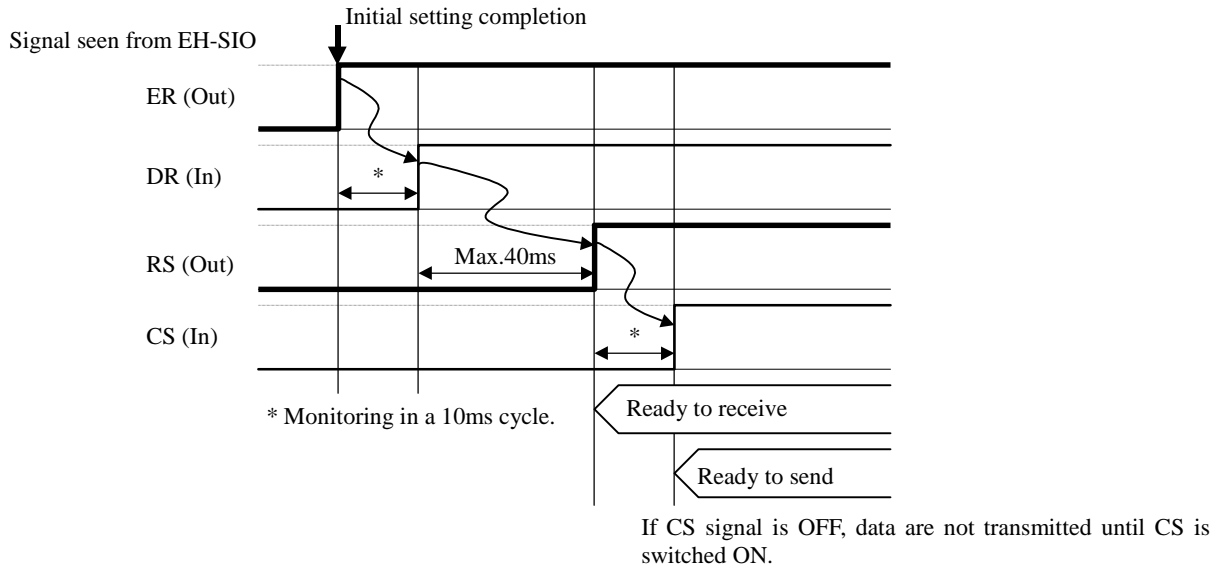

Figure 6.14 Flow chart up to beginning of communication when RS-232C I/F is in use

Since DR signal is checked with filtering, it takes more time to detect compared with other signals. In addition, "ER" and "RS" can be selected as automatic or manual, but even when manual operation is chosen, the operation follows the flow chart above. For example, when the RS flag is ON, the control register will be ON, and the actual signal line will not turn ON until the DR signal comes ON.

Reference : When a control line is not used

When there is no control signal in the connected device, please make the loop back connection (ER to DR, RS to CS). In this case, EH-SIO is ready to send / receive data 60 ms after initializing.

Please refer to section "4.3 Connection of the communication port" for more information on communication cable.

6.2.5 Receiving data

Received data is divided into packets according to the message composition registered in initial setting, and is stored in a receiving buffer. The number of effective receiving packets is displayed on an input register (for port 1: WXus2, and for port 2: WXus3).

EH-CPU reads one packet from the receiving buffer of EH-SIO by executing TRNS 9 command (data receive command). Only one packet can be read by one command execution. The packets are read in the order in which they were stored in the receiving buffer. In addition, when an error occurs at the time of data reception, error information is counted as one packet.

■ s parameter

Data receiving command from EH-CPU to EH-SIO is H0010

In addition, although the sending data area, specified by s+9 and s+A, is not used in this command. Please set dummy parameters in s+9 to s+A.

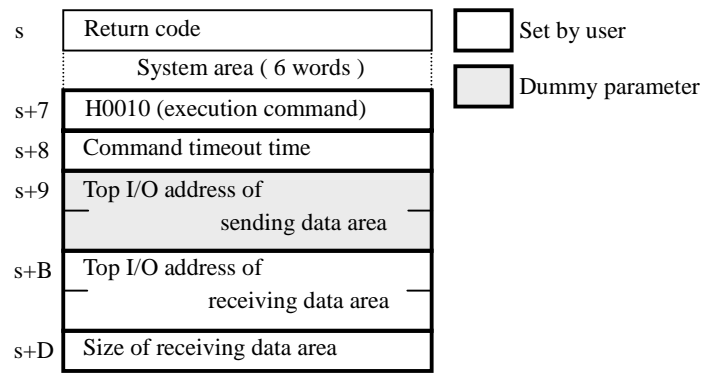

Figure 6.15 s parameter format (Free protocol / Data receiving)

■ Execution of data read

Please turn on command execution flag (t+0) after storing the parameter required for s parameter.

■ End of data read

(1) Receiving data are read

When receiving data are read properly, completion flag (t+1) goes on, and H0010 is set to return code area. The read data are stored according to s parameter s+B and s+D. (The number of data [byte] is stored at the top of the area.)

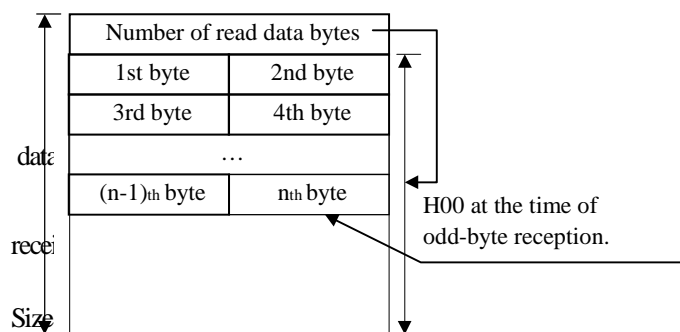

Figure 6.16 Receiving data area format (Free protocol)

When read data exceed the receiving area size, surplus data part is ignored.

(2) When error information is read

If an error occurs at data receiving, error code will be treated as one data packet. When EH-CPU reads the packet of error information, error flag (t+2) goes on, and error information is displayed on the return code area of s parameter. At this time, the number of received data bytes is set to 0, and the last data content is kept.

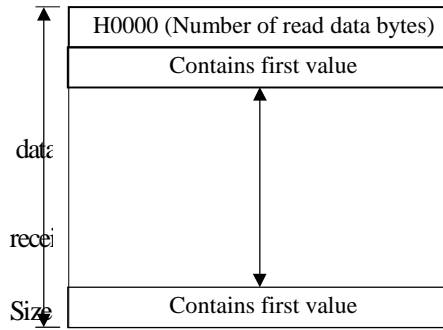

Figure 6.17 Receiving data area format (Free protocol)

« Note »

In case of error at data reading, previous data remain in receiving data area. Therefore, if a program which refers to the data part of receiving data area directly is created, old data will be referred to when errors occur.

By the methods as below, users can check if receiving command is executed properly.

- 1) The completion flag (t+1) ON of t parameter or the error flag (t+2) is monitored.
- 2) Return code area is monitored.

■ Sample program [Data reception]

(1) Ladder program

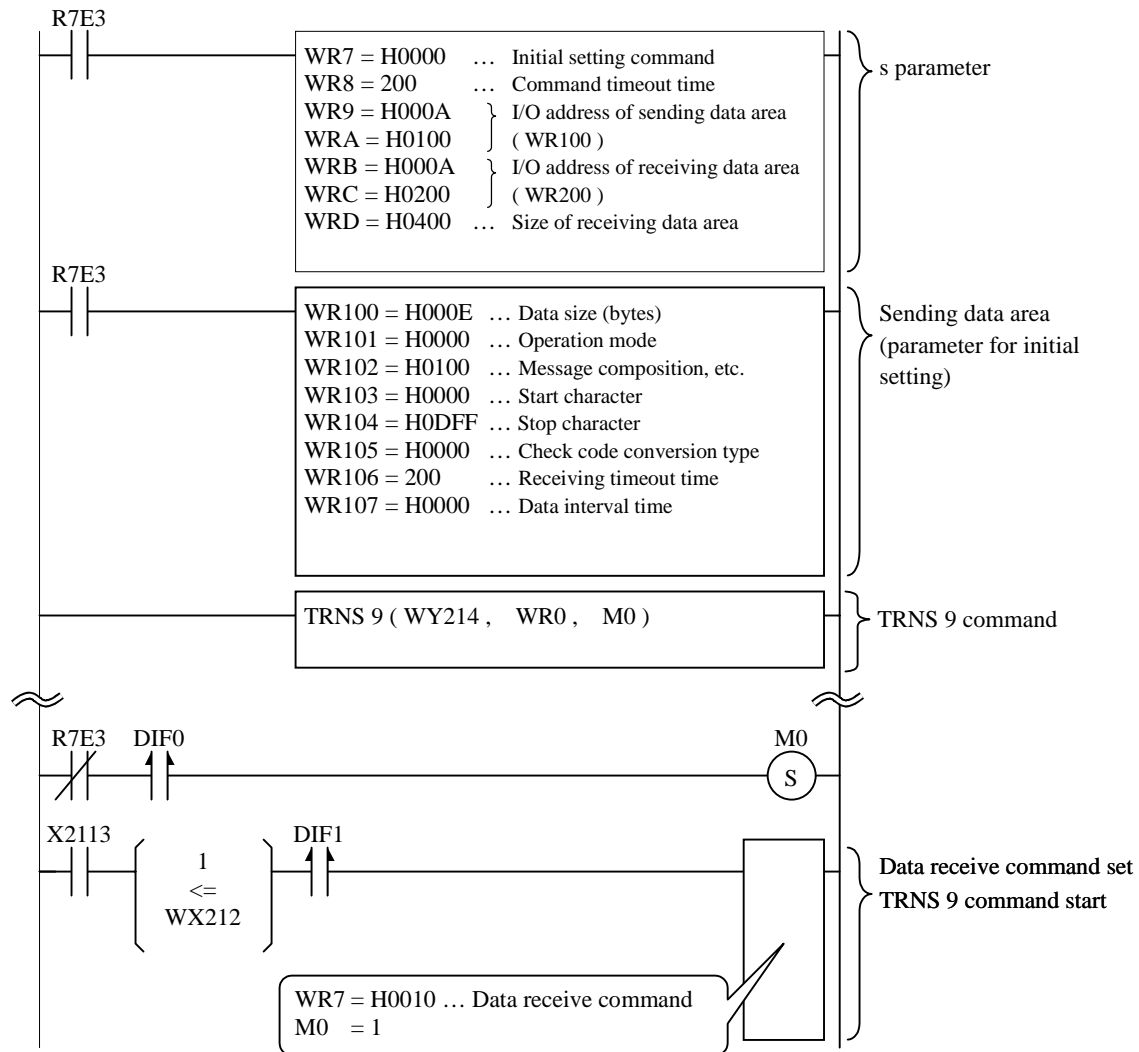

Reference : Refresh of Input / Output data

Since the I/O processing system of EH-150 is refreshment processing, the data of X and Y is usually refreshed at a scanning end. (In the case of the above program, it becomes a scanning end that X2113 and WX212 change.)

EH-150 are supporting the command refreshed for I/O data (FUN 80 – FUN 82) also in the middle of scan. Please describe, just before referring to X and WX if needed.

(2) Sample program description

The s parameter and the parameter of sending data area are set upon first scan.

After TRNS 9 command is completed, M0 will be ON and initial setting for the port 1 slot 1, unit 2 will be performed. X2113 in a program is a flag in the status register of EH-SIO, and if initial setting is completed, it is turned on.

After the initial setting completed, the port will start receiving operation. When data are received, the number of packets received via port 1 (input register value of WX212) will be counted.

In the last circuit of the above sample, even if one packet is received in port 1 of slot 1, unit 2, those data are read after WR200.

« Note »

As for the system area (WXus2 and 3) of an input register, software version is displayed till completion of initial setting. When you create a user program which refers to the number of packets, please use it combining the initial-setting completion flag (XICx) of a status register.

The contents of initial setting

Item	Setting value	Setting contents
Communication mode	H0000	Free protocol mode
Message composition	H01xx	Data + stop character
Control of modem line	Hxx0x	RS and ER regular ON
Data conversion type	Hxxx0	Through type
Start character	H0000	Not used
Stop character	H0DFF	CR (0D)
Check code calculation type	H0000	Not used
Receiving timeout interval	200	2000 ms
Data interval time	-	Disabled because of stop code used.

6.2.6 Data Sending

There are three types of data transmission: Sending only, Receives after sending, Send after receiving. The data sending type is specified by TRNS 9 command.

■ Data sending

Upon execution of TRNS 9 command, the specified data are transmitted from EH-SIO. When data are transmitted from EH-SIO, TRNS 9 command will be completed.

◆ TRNS 9 command s parameter at time of data transmission

Data sending command from EH-SIO to external device is H0020

In addition, although the receiving data area, specified by s+B and s+D, is not used in this command. Please set dummy parameters in s+B to s+D.

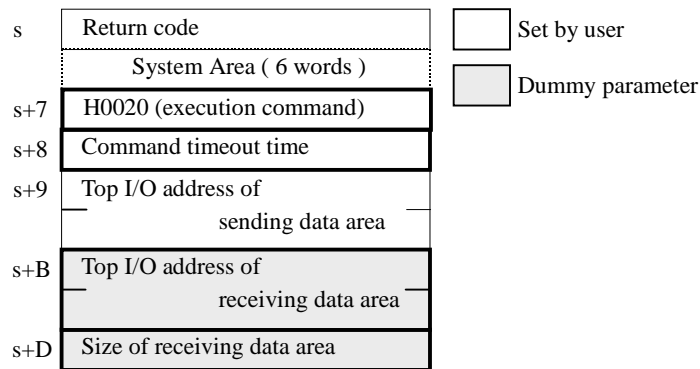

Figure 6.18 s parameter format (Free protocol / Data sending)

◆ Data to transmit

Store the sending data before execution of the TRNS 9 command. Set the number of data [byte] sending bytes into the top of the sending data area. Data should become after the next word.

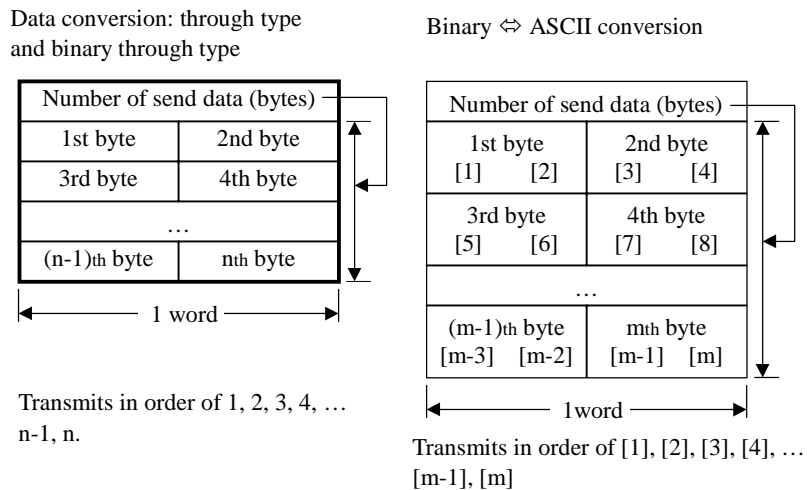

Figure 6.19 Sending data area format (Free protocol / Data sending)

◆ Execution of data sending.

Please turn on command execution flag (t+0) after storing the parameter required for s parameter and send data for the sent data area.

◆ End of data transmission.

When EH-SIO sends data properly, completion flag (t+1) will be ON, and H0020 will be set to return code area. If the transmission of data is failed, error flag (t+2) turns on, and error factor code is stored in the upper byte of return code area.

■ Receives after sending

When TRNS 9 command is executed, EH-SIO sends data and receives a reply data. When EH-CPU receives the data from EH-SIO, TRNS 9 command is completed.

◆ s parameter

Command for receives after sending is H0021

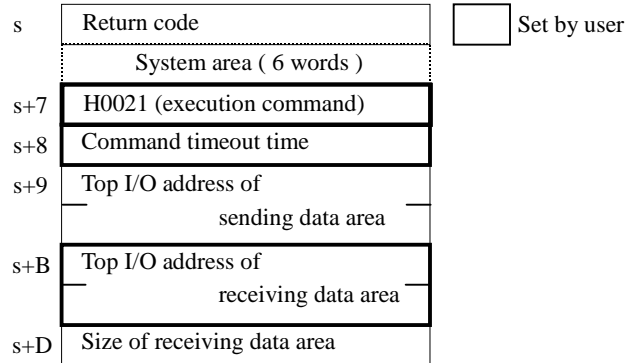

Figure 6.20 s parameter format (Free protocol / Receives after sending)

« Note »

When this command is executed, EH-SIO will clear the receiving buffer, even if previous data remained.

◆ Data to transmit

Please refer to command H0020 (sending only).

◆ Execution of command

Please turn on command execution flag (t+0) after storing the parameter required for s parameter and send data for the sent data area.

◆ The end of reception after data transmission

When EH-SIO sends data properly, completion flag (t+1) will be ON, and H0021 will be set to return code area. If the transmission of data is failed, error flag (t+2) turns on, and error factor code is stored in the upper byte of return code area.

■ Send after receiving

When TRNS 9 command is executed, EH-SIO will wait for data from an external device. When data is received, the specified data is sent. (Time between receive can be configured.) When data transmission is complete, EH-CPU will read the data which EH-SIO received. EH-CPU's acquisition of the data which EH-SIO received terminates the TRNS 9 command.

◆ s parameter

Command for send after receiving is Hxx22.

Upper byte of command word (s+7) is interval time between receiving and sending.

For example: for command H1022

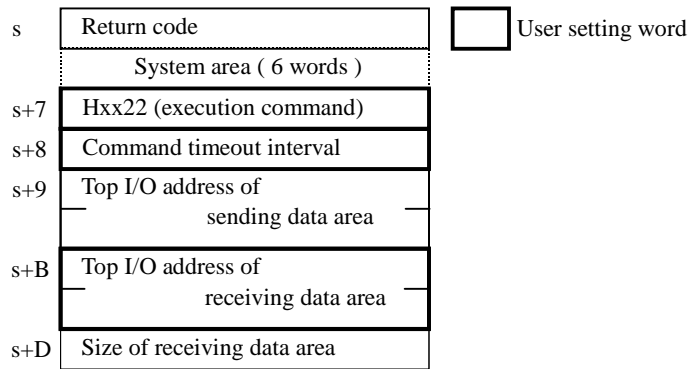
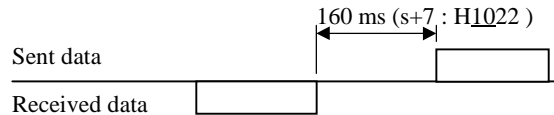

Figure 6.21 s parameter format (Free protocol / Send after receiving)

« Note »

- ◆ When this command is executed, EH-SIO will clear the receiving buffer, even if previous data remained.
- ◆ Received data become a reception packet according to the message composition registered in the initial setting. If EH-SIO detects an unusual factor in the received data, transmission will not be performed, and the abnormal contents will be returned to EH-CPU as a return code.

◆Data to transmit

Please refer to command H0020 (sending only).

◆Execution command

Please store the parameter required for the s parameter, set the number of transmitting data bytes and the transmission data for the sending data area, and turn on the command execution flag (t+0).

◆The end of reception after data transmission

When EH-SIO sends data properly, completion flag (t+1) will be ON, and H0022 will be set to return code area. If the transmission of data is failed, error flag (t+2) turns on, and error factor code is stored in the upper byte of return code area.

■ Sample program [Receives after sending]

(1) Ladder program

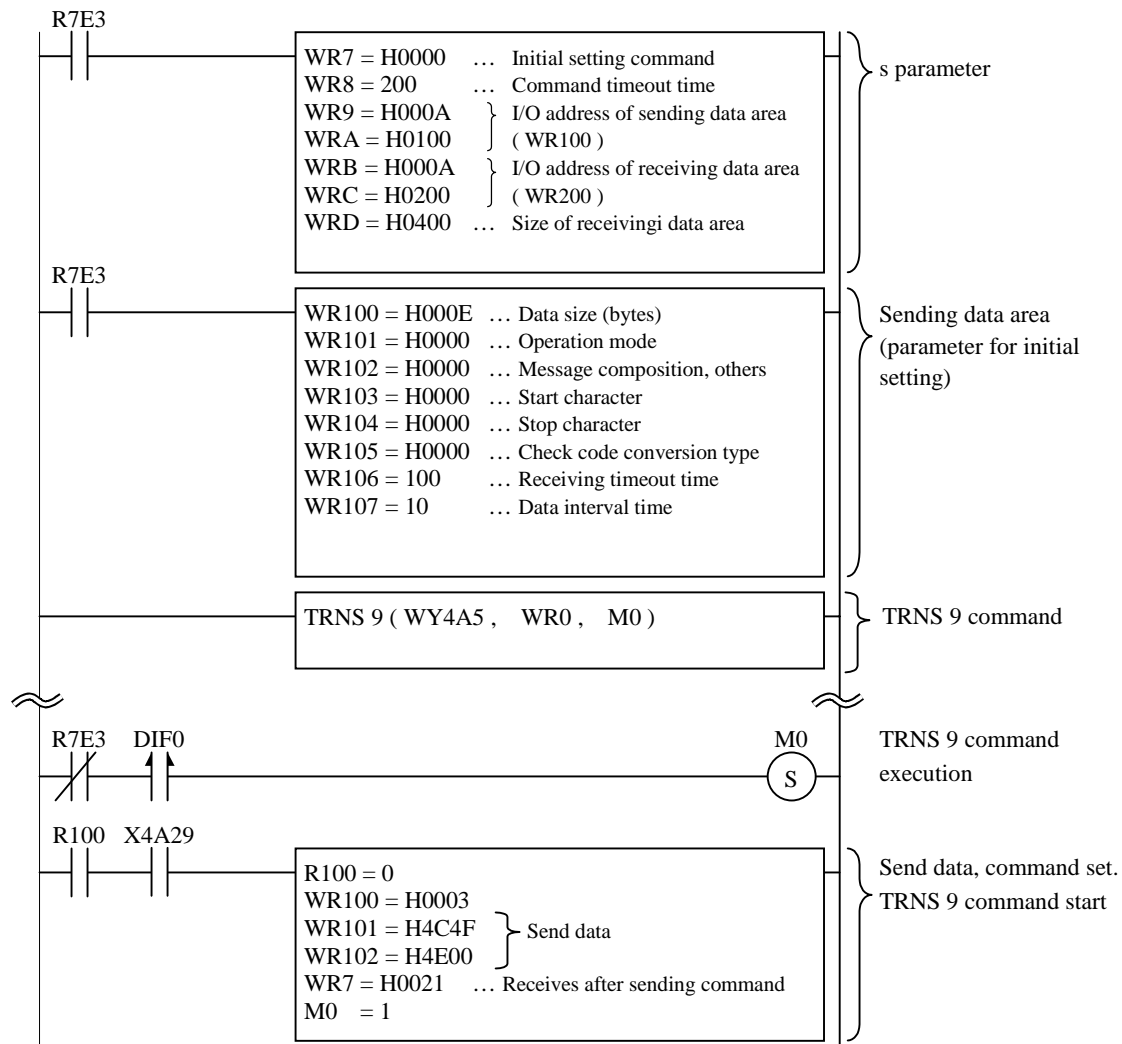

(2) Sample program description

The s parameter and the sending data area parameter are set upon the first scan.

M0 will be turned on at the 2nd scan, and initial setting for port 2 of slot A, unit 4 will be performed.

When R100 is turned on, then data “H4C4F4E” will be sent to a connected device. Reply data will be stored in WR200. Bit X4A29 is a status flag of EH-SIO. When initial setting is completed, this flag will be ON.

Item	Setting value	Setting contents
Communication mode	H0000	Free protocol mode
Message composition	H00xx	Only data
Control of modem line	Hxx0x	RS and ER regular ON
Data conversion type	Hxxx0	Through type
Start character	H0000	Not used
Stop character	H0000	Not used
Check code calculation type	H0000	Not used
Receiving timeout interval	100	1000 ms
Data interval time	10	Detect end of data according to 100ms interval

6.2.7 Error detection in free protocol mode

TRNS 9 command can check the execution results with t parameter and the details with s parameter. If error flag (t+2) of t parameter comes ON after TRNS 9 command execution, some type of error has occurred.

■Return code area

The execution result of the TRNS 9 command and the executed command are stored in return code area (s parameter head word).

s+0	Execution result	Execution command
-----	------------------	-------------------

If the command is executed properly, the result code is H00. The low byte of command in s+7 is stored in the low byte of return code area.

■Error code

The types of errors are divided into four categories.

- (1) Hardware errors of EH-SIO
- (2) Errors detected by the EH-CPU (mostly errors of s parameter)
- (3) Errors detected by the EH-SIO (errors of the parameter sent from EH-CPU, etc.)
- (4) Errors of communication data

Description (3) and (4) is shown blow. Refer to Section “A.4 TRNS 9 Return code” for a list of error codes.

Table 6.6 Free protocol mode abnormalities detected in EH-SIO

No.	Error code	Name	Error level	Details
1	H81	Non-supported command error	Warning	- Command not supported. - Initializing duplicates.
2	H82	Initial-setting error	Warning	- Parameter error in initializing - Initializing incomplete
3	H83	Transmission data error	Warning	Parameter error
4	H84	Receiving buffer full	Warning	The input buffer of EH-SIO is filled with the receiving data which is not read by CPU.
5	H85	Connection error	Warning	Since DR signal from external device is OFF, data cannot be transmitted.

« Note »

- ◆ EH-SIO has two buffers: The one is receiving data buffer and the other is error information buffer. If the receiving data buffer becomes full and error information buffer is also full, the ER signal is turned off regardless of automatic / manual setup.
- ◆ If data exceeding 1,024 bytes is received, the error code is not H84(Receiving buffer full), but H91(“Inaccurate data content of message”). Please refer to next page about error code H91.

Table 6.7 Free protocol mode abnormalities detected at time of communication

No.	Error code	Item	Error level	Details
1	H8A	Parity error	Warning	Parity error in receiving data.
2	H8B	Framing error	Warning	Framing error in receiving data.
3	H8C	Overrun error	Warning	Overrun error in receiving data.
4	H8D	Check code error	Warning	Check code error in receiving data.
5	H8E	Receiving timeout error	Warning	Reception of data was not completed within the time specified by EH-SIO.
6	H8F	Sending timeout error	Warning	EH-SIO did not complete transmission of data by within the time interval. (Monitoring time is fixed by the system. It cannot be changed.)
7	H91	Inaccurate data content of message	Warning	A message containing inaccurate data was transmitted and received. (Example: The wording is correct as a telegram message, but the contents of the data are abnormal ASCII data.)

« Note »

EH-SIO monitors every byte for parity error, framing error, etc. Therefore, if it communicates in a situation differs from transmission code configuration or transmission speed, even if the data were originally data only one packet, they may become two or more packets because of the error information.

6.3 Modbus master mode

In modbus master mode, EH-SIO is able to send requests (called “query” in this manual) according to the modbus protocol to an external device (a maximum of 32 sets), and receives an answer (called “response” in this manual) from external device by TRNS 9 command.

A connected device works according to function code, which is included in a query.

6.3.1 Overview

Upon completion of initial setting, EH-SIO will be waiting for query transmission. Query is sent by TRNS 9 command. When the parameter for sending data area is stored and TRNS 9 command is executed, EH-SIO will generate query and will send it. When the reply comes, EH-SIO stores data in the receiving data area of EH-CPU according to the format.

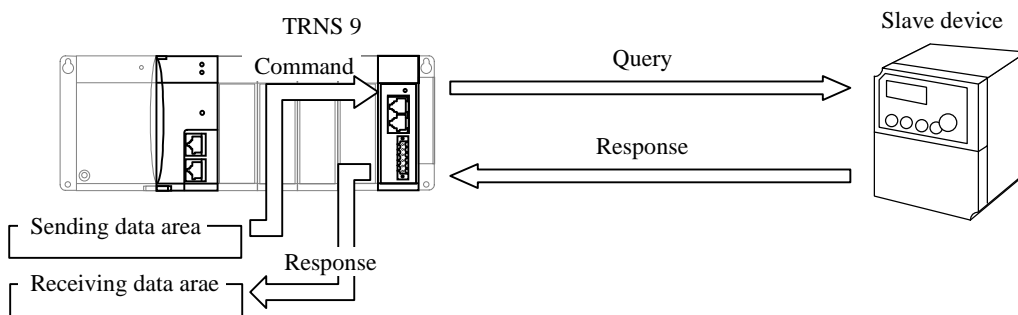

Figure 6.22 Overview of Modbus master mode

■ Error detection

(1) EH-SIO hardware error

Hardware error is detected by the self-diagnostic function of EH-SIO, operation will stop if a serious failure occurs. In this case, please reboot the power, or push the reset switch on the front of the module.

(2) Query error

An error code is stored in the return code area of TRNS 9 command, when data error is detected or when communication errors (a parity error, abnormalities in a check code, etc.) are detected. Operation will not stop upon these errors. Rebooting or resetting are not necessary.

(3) An exception response from the external device

Although the communication itself may be performed normally, when the message format is not correct (for example, the specified function code is not supported), an exception response returns from slaves. When an exception response is received, EH-SIO stores an exception response code in the receiving data area and return code area of TRNS 9 command. Operation will not stop upon these errors. Rebooting or resetting are not necessary.

6.3.2 User project structure

Following user project structure is required in case of usage of Modbus master mode of EH-SIO.

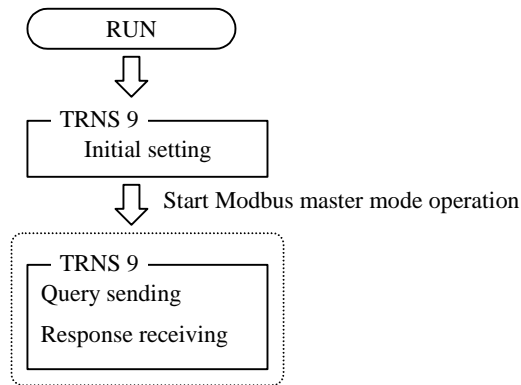

Figure.6.23 User project structure (Modbus master)

[STEP 1]

To configure communication port of EH-SIO as Modbus master mode by using TRNS9 command.

[STEP 2]

The program which transmits query is performed. (By one TRNS 9 command execution, it carries out to the response reception from a slave.)

Regarding initial configuration and query sending (response reception) detailed, explanation are shown in subsequent paragraphs.

6.3.3 Initial setting

When power is turned ON, EH-SIO will be in idle state (initial setting waiting from EH-CPU). Operation in modbus master mode is started by initial setting from EH-CPU.

In addition, once initial setting is completed, the setting cannot be changed, unless EH-CPU is stopped or EH-SIO is reset.

« Note »

In there is no initial setting, EH-SIO will not receive any other command from EH-CPU and external device than initializing command.

■ Parameters for initial setting

Table 6.8 Parameters list for initial setting

No.	parameter	Contents
1	Operation mode	Be sure to set modbus master mode (H0010)
2	Modbus transmission mode	Select RTU mode (0) or ASCII mode (1). Only RTU mode is supported by ver. 1.0.
3	Receiving timeout interval	Specify timeout if necessary The definition of timeout is as follows. [1] No response with in specified time. [2] Data receiving not completed within specified time.

■ s parameter of TRNS 9 command for initial setting

Initializing command (specified as s+7) is H0000.

Although nothing is stored in the receiving data area specified by s+B to s+D upon the performance of the initial-setting command, each parameter needs to be specified.

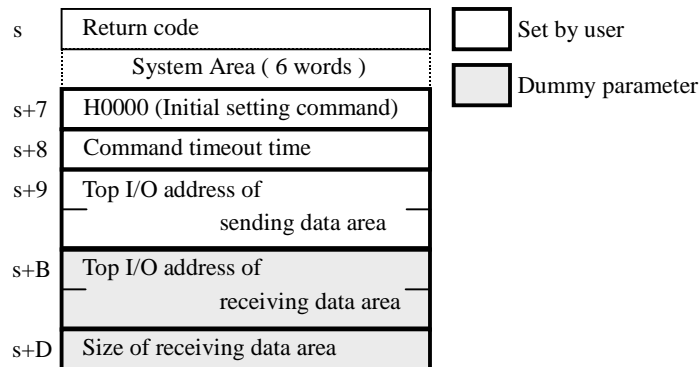

Figure 6.24 s parameter format (Modbus master / Initial setting)

■ Sending data area for initial setting

Sending data area (head address is specified as s+9 and s+A) format is as follows:

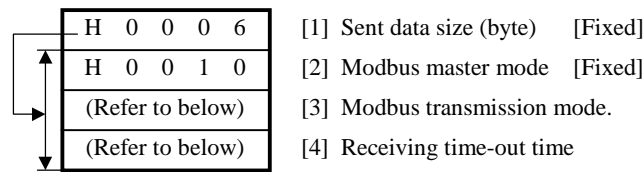

Figure 6.25 Sending data area format (Modbus master / Initial setting)

The meaning of each parameter described as below.

[1] Sent data size (byte)

Set 6 byte (H0006) in case of modbus master mode (initial setting).

[2] Communication mode

When you using modbus master mode, please set to H0010.

[3] Modbus transmission mode

Modbus transmission mode is specified as either ASCII mode or RTU mode.

Table 6.9 Modbus transmission mode

Setting value	Transmission mode
H0000	RTU mode
Others	ASCII mode (Not supported in Ver. 1.0)

[4] Receiving timeout time

Receiving timeout is defined as time between the end of query and the end of received response.

= H0000 → Timeout disabled.

≠ H0000 → Timeout enabled in setting time x 10ms. The maximum timeout is HFFFF.

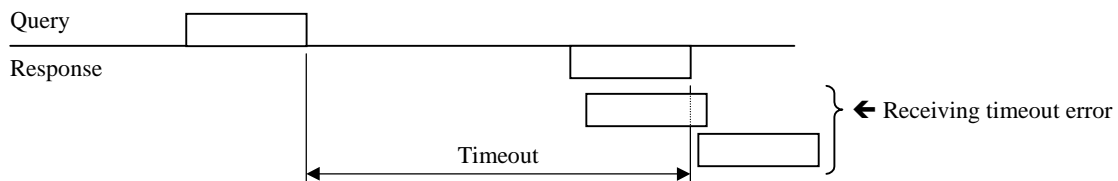

Figure 6.26 Monitoring of receiving timeout

■ Execution of initial setting

After the required s parameter and parameter for sending data are stored, please turn on the command execution flag (t+0).

■ End of initial setting

(1) Completed properly

H0000 is stored in return code area (s+0), and completion flag (t+1) goes on. A status register XICx goes on and LNK and HPx on the LED will be off.

(x-1: Port 1, 2: Port 2)

(2) Error

Error flag (t+2) goes on, and error code will be stored in return code area. Please eliminate the error factor by referring to the return code in section “6.3.5 Error detection in modbus master mode”.

■ Sample program [Initial setting]

(1) Ladder program

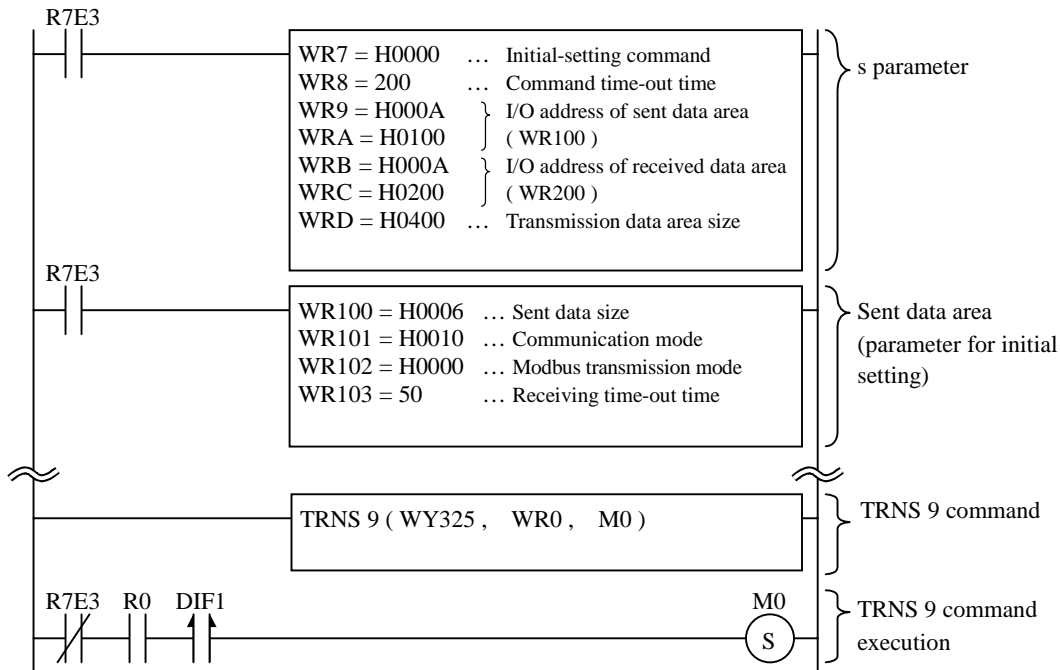

(2) Sample program description

The s parameter and the parameter of sending data area are set upon first scan.

If R0 is turned on, the following initial setting is configured on port 2 mounted on slot 2 of unit 3.

Item	Setting value	Set-up contents
Communication mode	H0010	Modbus master mode
Modbus transmission mode	H0000	RTU mode
Receiving time-out time	50	500 ms

« Note »

TRNS 9 is initialized at the 1st scan. So other settings and operations should be executed after the 2nd scan.

6.3.4 Query transmission, Response reception

- The TRNS 9 command s-parameter at time of query transmission

Command (specified as s+7) of query sending is H0080

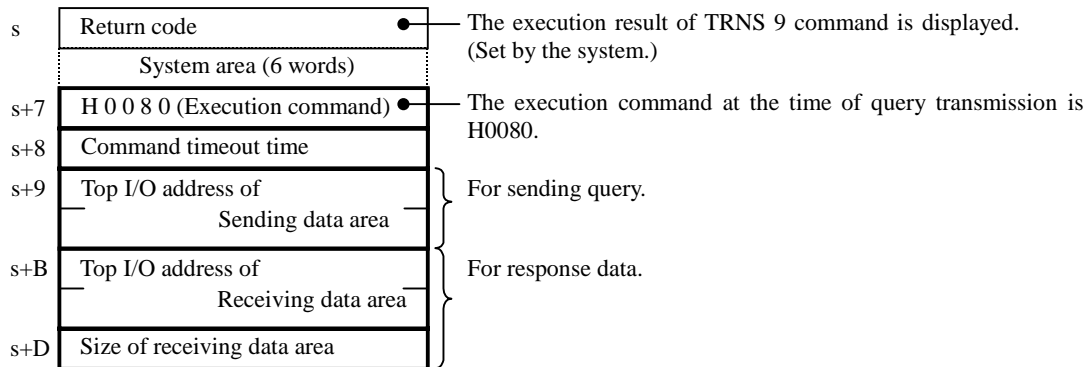

Figure 6.27 s parameter format (Modbus master / Query transmission)

- Execution of query transmission

After setting each parameter in Fig. 6.27 to s parameter area and storing the query parameter in the sending data area, please turn ON the command execution flag (t+0). (The format of the query data area depends on function code.)

- Response reception

Response data is automatically stored receiving data area with completion flag being ON. (In modbus master mode, one cycle of TRNS 9 command is from sending to receiving.)

When any errors from the slave response are detected or an exception response is returned, an error flag (t+2) turns on. The exception response data (exception code) is stored in the receiving data area.

« Note »

EH-SIO checks the validity of the response code, the function code, and the check code only. Therefore, if the above-mentioned item is correct, the data are stored in receiving data area even if more data than requested is received.

■ EH-SIO support function codes

EH-SIO supports the function codes shown in the following table.

Table 6.10 EH-SIO support functions

Function Code	Function	Broadcasting	
01 (0x01)	Read Coil Status	State of coil is read.	-
02 (0x02)	Read Input Status	State of input status is read.	-
03 (0x03)	Read Holding Registers	State of holding register is read.	-
04 (0x04)	Read Input Registers	State of input register is read.	-
05 (0x05)	Force Single Coil	State of coil changes between ON/OFF.	OK
06 (0x06)	Preset Single Register	State of holding register is changed.	OK
15 (0x0F)	Force Multiple Coils	State of two or more coils changes between ON/OFF.	OK
16 (0x10)	Preset Multiple Registers	State of two or more holding registers is changed	OK

■ Exception code

When the contents of a query message are inaccurate or a slave cannot process the query, the slave returns an exception response including error factor.

Table 6.11 Exception code list

Exception code	Item	Meaning
01	Illegal function	Requested function is not supported
02	Illegal data address	Specified data address does not exist in the slave.
03	Illegal data value	Data value is not allowed for the slave.
04	Slave device failure	An unrecoverable error occurred in the slave.
05	Acknowledge	Although query is recognized, it takes time to reply. (To prevent timeout error.)
06	Slave device busy	Processing of previous query.

Reference : Modbus data address

Data address must be specified for data reading and writing. According to the “Modbus Protocol Reference Guide” there are four types of data (coil, input status, input register, and holding register).

- (1) Coil Bit data from 1 to 9,999 for reading and writing.
- (2) Input status Bit data from 10,001 to 19,999 for reading only.
- (3) Input register Word data from 30,001 to 39,999 for reading only.
- (4) Holding register Word data from 40,001 to 49,999 for reading and writing.

Since data type is specified by function code, the address in message is only 4 digits. Moreover, if the address of a message format is set to "0000", then the specified address is "x0001" (x being the maximum higher rank for each data classification).

Ex.) Input register Data address 10789

4 low figures 789 → Offset from Address 788 → Specification of data address 0x0314

Hereafter, the explanation of each function code is written in accordance with this.

■ Function code 0x01 (Read Coil Status)

The function code 01 is a query to read the state of coil of the slave system. Broadcasting is not supported.

(1) Sending data area format

Sending data area requires 4 words. Please set 6 bytes for head word.

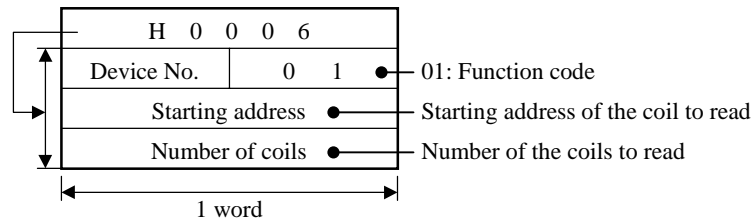

Figure 6.28 Sending data area format (Function code 0x01)

- 1) Device No.: Please set the code of the slave to a hexadecimal number. (H01 to HFF. H00 cannot be used.)
- 2) Set function code to H01.
- 3) Starting address: Set the head address of the reading coil to a hexadecimal number. (H0000 to HFFFF)
- 4) Number of coils: Set the number of the reading coils to a hexadecimal number. (H0000 to H07F0)

Ex.) When reading the situation of 16 coils from address 32 of the slave No.24.

The head address of sending data area WR100 → WR100 = H0006
 WR101 = H1801
 WR102 = H001F
 WR103 = H0010

(2) The state of receiving data area

1) Completed properly

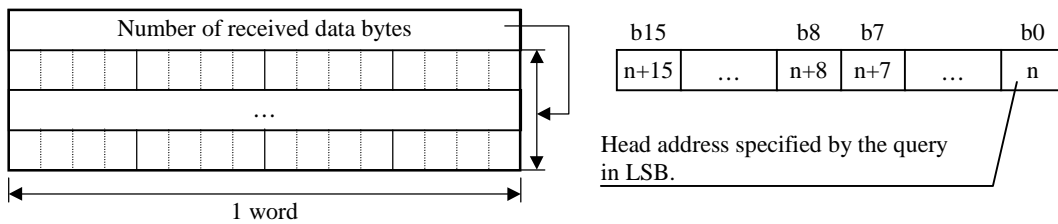

Figure 6.29 Receiving data area format (Function code 0x01)

When a response is received properly from the slave, completion flag (t+1) will be ON, and the coil information is stored in the address specified by the query from LSB. Since the information on the coil is handled per byte, 0 is stored in the remaining area when the information on a coil does not fill 1 byte.

For example, when nine pieces of coil are read, 0 is stored in b9-b15.

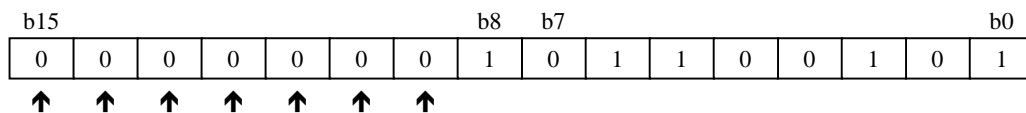

Figure 6.30 Storing of coil information (not fill 1 byte)

EH-SIO handles coil data by word unit. If received data from the slaves is odd number byte, this data will be sent to EH-CPU as even number byte with one byte attached.

2) Receiving exception response

When an exception response is received, error flag (t+2) turns on, and the receiving data area is as follows.

Number of received data bytes (H0002)	
H 8 1	Exception code

Figure 6.31 Receiving data area format (Function code 0x01 / Exception response)

3) Other errors (except for exception response)

When there is no response from a slave or an abnormal factor is detected in the response, error flag (t+2) turns on, an error code is stored in the return code area of the s parameter, and the number of receiving data area is cleared to H0000. (Data other than the number of acquisition data bytes maintains previous values.)

Please refer to section “6.3.5 Error detection in modbus master mode” for more information on error codes.

■ Function code 0x02 (Read Input Status)

The function code 02 is a query to read input status of the slave. Broadcasting is not supported.

(1) Sending data area format

Sending data area requires 4 words. Please set head word to 6 bytes.

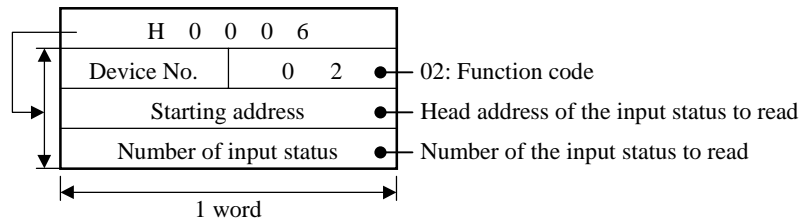

Figure 6.32 Sending data area format (Function code 0x02)

- 1) Device No.: Please set the code of the slave to a hexadecimal number. (H01 to HFF. H00 cannot be used.)
- 2) Set function code to H02.
- 3) Start address: Set the reading head address of the input status to a hexadecimal number. (H0000 to HFFFF)
- 4) Input status number: Set the reading number of the input status to a hexadecimal number. (H0000 to H07F0)

Ex.) When reading the situation of 48 input status from the address 10321 of the code 01 slave.

The head address of Sending data area WR100 → WR100 = H0006
 WR101 = H0102
 WR102 = H0140
 WR103 = H0030

(2) The state of receiving data area

1) Completed properly

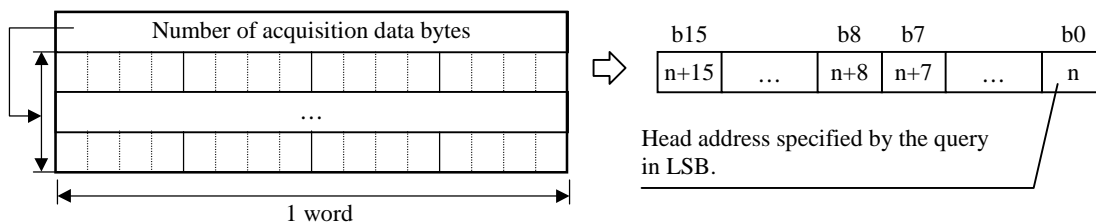

Figure 6.33 Receiving data area format (Function code 0x02)

When a response is received properly from the slave, completion flag (t+1) will be ON, and the input status information is stored in the address specified by the query from LSB. (same as function code 0x01.) Data unit of EH-SIO is one word same as function code 01.

2) Receiving exception response

When an exception response is received, error flag (t+2) turns on, and the receiving data area is as follows.

Number of received data bytes (H0002)	
H 8 2	Exception code

Figure 6.34 Receiving data area format (Function code 0x02 / Exception response)

3) Other errors (except for exception response)

When there is no response from a slave or an abnormal factor is detected in the response, error flag (t+2) turns on, an error code is stored in the return code area of the s parameter, and the number of receiving data area is cleared to H0000. (Data other than the number of acquisition data bytes maintains previous values.)

Please refer to section “6.3.5 Error detection in modbus master mode” for more information on error codes.

■ Command 0x03 (Read Holding Registers)

The function code 03 is a query to read holding register of the slave system. Broadcasting is not supported.

(1) Sending data area format

Sending data area requires 4 words. Please set head word to six transmission bytes.

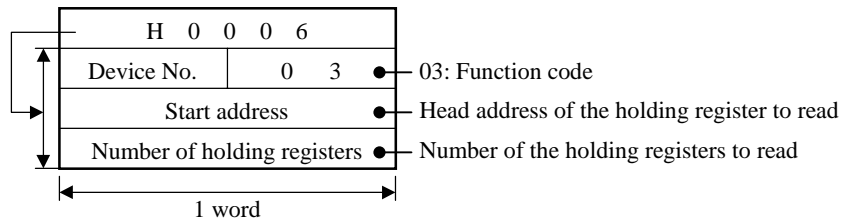

Figure 6.35 Sending data area format (Function code 0x03)

- 1) Device No.: Please set the code of the slave to a hexadecimal number. (H01 to HFF. H00 cannot be used.)
- 2) Set function code to H03.
- 3) Start address: Set the reading head address of the holding register to a hexadecimal number. (H0000 to HFFFF)
- 4) Number of holding registers: Set the reading number of the holding registers to a hexadecimal number. (H0000 to H00FE)

Ex.) When reading the situation of 12 holding registers from the address 40129 of the code 7 slave.

The head address of Sending data area WR100 → WR100 = H0006
 WR101 = H0703
 WR102 = H0080
 WR103 = H000C

(2) The state of receiving data area

- 1) Completed properly

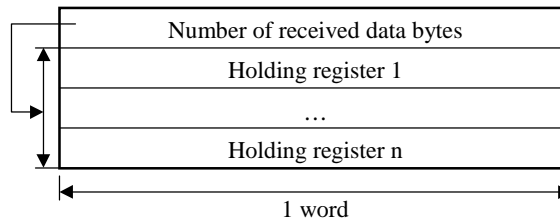

Figure 6.36 Receiving data area format (Function code 0x03)

When a response is received properly from the slave, completion flag (t+1) will be ON, and the holding register information is stored in the address specified by the query from head word.

- 2) Receiving exception response

When an exception response is received, error flag (t+2) turns on, and the receiving data area is as follows.

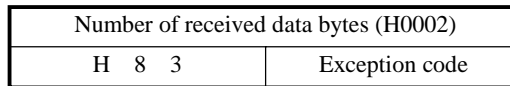

Figure 6.37 Receiving data area format (Function code 0x03 / Exception response)

- 3) Other errors (except for exception response)

When there is no response from a slave or an abnormal factor is detected in the response, error flag (t+2) turns on, an error code is stored in the return code area of the s parameter, and the number of receiving data area is cleared to H0000. (Data other than the number of acquisition data bytes maintains previous values.)

Please refer to section “6.3.5 Error detection in modbus master mode” for more information on error codes.

■ Command 0x04 (Read Input Registers)

The function code 04 is a query to read input register of slave apparatus. Broadcasting is not supported.

(1) Sending data area format

Sending data area requires 4 words. Please set head word to six transmission bytes.

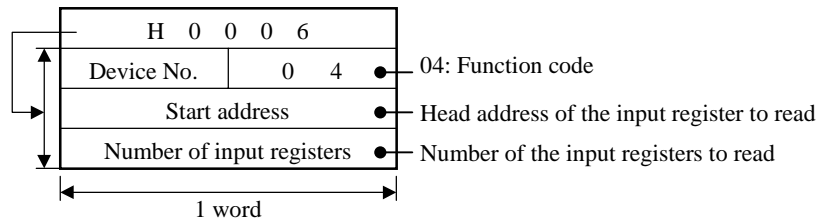

Figure 6.38 Sending data area format (Function code 0x04)

- 1) Device No.: Please set the code of the slave to a hexadecimal number. (H01 to HFF. H00 cannot be used.)
- 2) Set function code to H04.
- 3) Start address: Set the reading head address of the holding register to a hexadecimal number. (H0000 to HFFFF)
- 4) The number of input registers : Set the reading number of the input registers to a hexadecimal number. (H0000 to H00FE)

Ex.) When reading the situation of 104 input registers from the address 30464 of code 14 slave.

The head address of Sending data area WR100 →
 WR100 = H0006
 WR101 = H0E04
 WR102 = H01CF
 WR103 = H0068

(2) The state of receiving data area

- 1) Completed properly

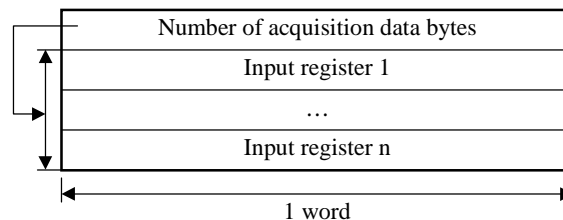

Figure 6.39 Receiving data area format (Function code 0x04)

When a response is received properly from the slave, completion flag (t+1) will be ON, and the input register information is stored in the address specified by the query from head word.

- 2) Receiving exception response

When an exception response is received, error flag (t+2) turns on, and the receiving data area is as follows.

Number of received data bytes (H0002)	
H 8 4	Exception code

Figure 6.40 Receiving data area format (Function code 0x04 / Exception response)

- 3) Other errors (except for exception response)

When there is no response from a slave or an abnormal factor is detected in the response, error flag (t+2) turns on, an error code is stored in the return code area of the s parameter, and the number of receiving data area is cleared to H0000. (Data other than the number of acquisition data bytes maintains previous values.)

Please refer to section “6.3.5 Error detection in modbus master mode” for more information on error codes.

■ Command 0x05(Force Single Coil)

The function code 05 is a query to change state of coil of the slave to ON/OFF (only 1 point.). In broadcasting, the state of the same coils of all slaves is changed.

(1) Sending data area format

Sending data area requires 4 words. Please set head word to 6 bytes.

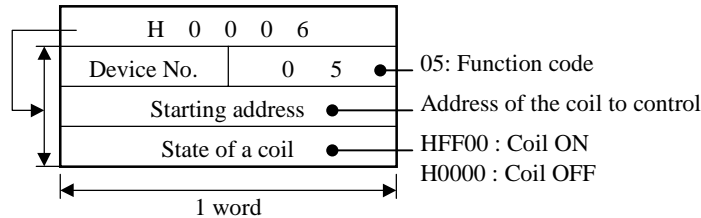

Figure 6.41 Sending data area format (Function code 0x05)

- 1) Please set the device No. of the slave to a hexadecimal number. (H01 to HFF. H00 is for broadcast.)
- 2) Set function code to H05.
- 3) Start address: Please set the address of the coil to change to a hexadecimal number. (H0000 to HFFFF)
- 4) The state of the coil: Please set the state of the coil to change. (For changing to ON: HFF00; for changing to OFF: H0000)

Ex.) When the 253rd coil of the code 44 slave is turned on:

The head address of Sending data area WR100 →
 WR100 = H0006
 WR101 = H2C05
 WR102 = H00FC
 WR103 = HFF00

(2) The state of receiving data area

1) Completed properly

When performance is properly, completion flag (t+1) will be ON, and nothing is stored in receiving data area. A properly execution code is stored in a return code (s+0).

2) Receiving exception response

When an exception response is received, error flag (t+2) turns on, and the receiving data area is as follows.

Number of received data bytes (H0002)	
H 8 5	Exception code

Figure 6.42 Receiving data area format (Function code 0x05 / Exception response)

3) Other errors (except for exception response)

When there is no response from a slave or an abnormal factor is detected in the response, error flag (t+2) turns on, an error code is stored in the return code area of the s parameter, and the number of receiving data area is cleared to H0000. (Data other than the number of acquisition data bytes maintains previous values.)

Please refer to section “6.3.5 Error detection in modbus master mode” for more information on error codes.

■ Command 0x06 (Preset Single Register)

The function code 06 is a query to change state of the holding register of the slave. In broadcasting, the state of the same holding registers of all slaves is changed.

(1) Sending data area format

Sending data area requires 4 words. Please set the head word to 6 bytes.

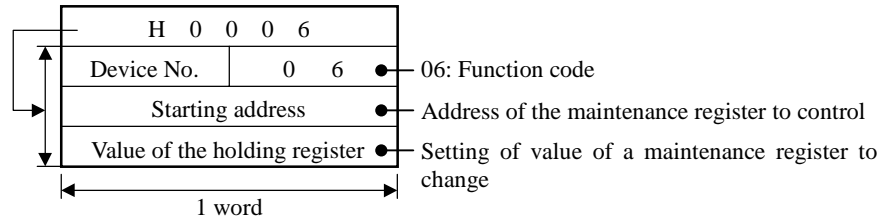

Figure 6.43 Sending data area format (Function code 0x06)

- 1) Device No.: Please set the code of the slave to a hexadecimal number. (H01 to HFF. H00 is broadcast.)
- 2) Set function code to H06.
- 3) Start address: Please set the address of the holding register to change to a hexadecimal number. (H0000 to HFFFF)
- 4) The state of a holding register: Please set the value of the holding register to change.

Ex.) When the value of register 40255 of the code 51 slave is changed to H54AC:

The head address of Sending data area WR100 →

WR100 = H0006
WR101 = H3306
WR102 = H00FE
WR103 = H54AC

(2) The state of receiving data area

1) Completed properly

When performance is properly, completion flag (t+1) will be ON, and nothing is stored in receiving data area. A properly execution code is stored in a return code (s+0).

2) Receiving exception response

When an exception response is received, error flag (t+2) turns on, and the receiving data area is as follows.

Number of received data bytes (H0002)	
H 8 6	Exception code

Figure 6.44 Receiving data area format (Function code 0x06 / Exception response)

3) Other errors (except for exception response)

When there is no response from a slave or an abnormal factor is detected in the response, error flag (t+2) turns on, an error code is stored in the return code area of the s parameter, and the number of receiving data area is cleared to H0000. (Data other than the number of acquisition data bytes maintains previous values.)

Please refer to section “6.3.5 Error detection in modbus master mode” for more information on error codes.

■ Command 0x0F (Force Multiple Coils)

Function code 0F is a query to change state of two or more coils of slave. In broadcasting, the state of the same coils of all slaves is changed.

(1) Sending data area format

Sending data area changes with the number of coils to change. Please set the head word to number of transmission bytes.

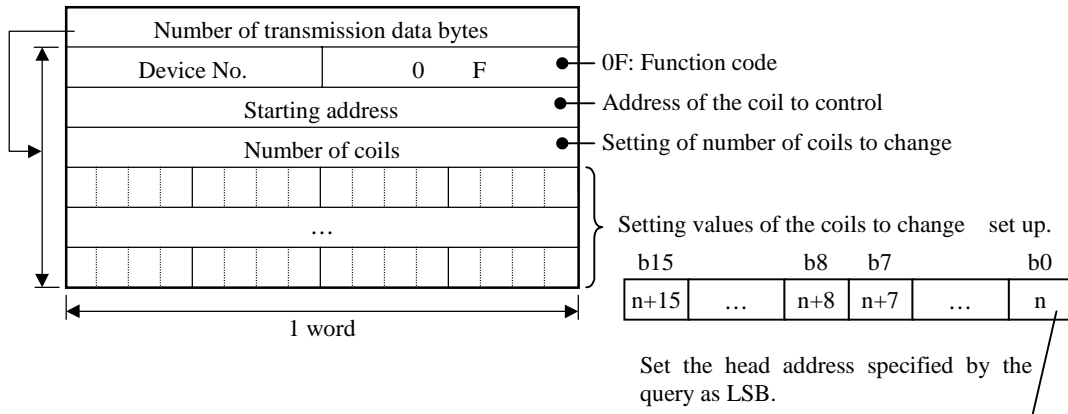

Figure 6.45 Sending data area format (Function code 0x0F)

- 1) Please set the device No. of the slave to a hexadecimal number. (H01 to HFF. H00 is for broadcast.)
- 2) Set function code to H0F.
- 3) Start address: Please set the head address of the coil to change to a hexadecimal number. (H0000 to HFFFF)
- 4) The number of coils: Please set the number of the coils to change to a hexadecimal number. (H0001 to H07F0)
- 5) State of coils: Please set the state of the coils to change. (ON: 1, OFF: 0)

Ex.) When the values of all eight coils from number 17 of the code 39 slave are changed to ON:

The head address of Sending data area WR100 → WR100 = H0008
 WR101 = H270F
 WR102 = H0010
 WR103 = H0008
 WR104 = H00FF

« Note »

Be sure to set an even number for the transmission data bytes.

For example, when the number of the coils to set is 19 bits (3 bytes), please set the high byte of last data to H00, and set the number of transmission data bytes including H00.

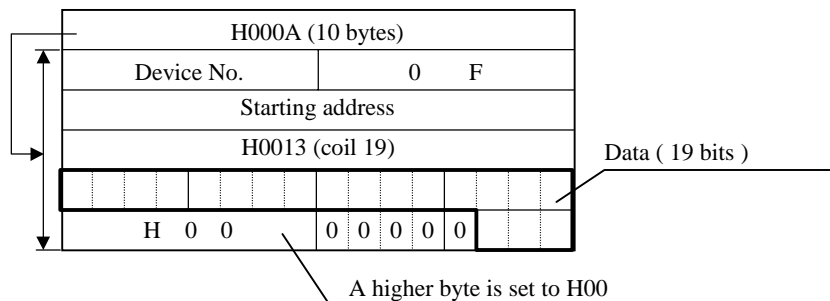

(2) The state of receiving data area

1) Completed properly

When performance is properly, completion flag (t+1) will be ON, and nothing is stored in receiving data area. A properly execution code is stored in a return code (s+0).

2) Receiving exception response

When an exception response is received, error flag (t+2) turns on, and the receiving data area is as follows.

Number of received data bytes (H0002)	
H 8 F	Exception code

Figure 6.46 Receiving data area format (Function code 0x0F / Exception response)

3) Other errors (except for exception response)

When there is no response from a slave or an abnormal factor is detected in the response, error flag (t+2) turns on, an error code is stored in the return code area of the s parameter, and the number of receiving data area is cleared to H0000. (Data other than the number of acquisition data bytes maintains previous values.)

Please refer to section “6.3.5 Error detection in modbus master mode” for more information on error codes.

■ Command 0x10 (Force Multiple Registers)

Function code 10 is a query to change two or more holding registers of slave. In broadcasting, the state of the same holding registers of all slaves is changed.

(1) Sending data area format

Sending data area changes with the number of the holding registers to change. Please set the head word to the number of transmission bytes.

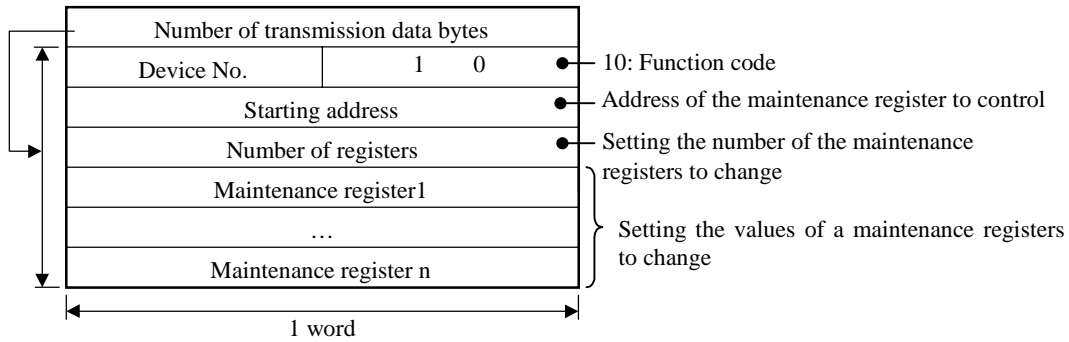

Figure 6.47 Sending data area format (Function code 0x10)

- 1) Device No.: Please set the code of the slave to a hexadecimal number. (H01 to HFF. H00 is for broadcast.)
- 2) Set function code to H0F.
- 3) Start address: Please set the head address of the holding register to change to a hexadecimal number. (H0000 to HFFFF)
- 4) The number of holding registers: Please set the number of the holding registers to change to a hexadecimal number. (H0000 to H007F)
- 5) State of holding registers: Please set the state of the holding registers to change.

Ex.) When the values of holding registers 40101 and 40102 of the code 90 slave are changed into H1234 and H5678:

The head address of Sending data area WR100 →
 WR100 = H000A
 WR101 = H5A10
 WR102 = H0064
 WR104 = H0002
 WR105 = H1234
 WR106 = H5678

(2) The state of receiving data area

1) Completed properly

When performance is properly, completion flag (t+1) will be ON, and nothing is stored in receiving data area. A properly execution code is stored in a return code (s+0).

2) Receiving exception response

When an exception response is received, error flag (t+2) turns on, and the receiving data area is as follows.

Number of acquisition data bytes (H0002)	
H 9 0	Exception code

Figure 6.48 Receiving data area format (Function code 0x10 / Exception response)

3) Other errors (except for exception response)

When there is no response from a slave or an abnormal factor is detected in the response, error flag (t+2) turns on, an error code is stored in the return code area of the s parameter, and the number of receiving data area is cleared to H0000. (Data other than the number of acquisition data bytes maintains previous values.)

Please refer to section “6.3.5 Error detection in modbus master mode” for more information on error codes.

6.3.5 Error detection in modbus master mode

TRNS 9 command can check the execution results with t-parameter and the details with s parameter. If error flag (t+2) of t parameter comes ON after TRNS 9 command execution, some type of error has occurred.

■ Return code area

The TRNS 9 command execution results and the executed command (H80) are stored in return code area (s parameter head word).

s+0	Execution result	Execution command (H80)
-----	------------------	-------------------------

Exception result H00 means operation is completed properly. Other values are error code as below table.

■ Error code

The types of errors are divided into four categories. (Please refer to section “A.4 TRNS 9 Return code” for details on EH-SIO hardware errors and error detected by EH-CPU.)

Table 6.12 Modbus master mode errors detected by EH-SIO

No.	Error code	Item	Error level	Details
1	H81	Command not supported	Warning	<ul style="list-style-type: none"> ◆ Issued command is not supported. ◆ Initializing command is executed more than twice.
2	H82	Initial setting error	Warning	<ul style="list-style-type: none"> ◆ The parameter of initial setting is wrong. ◆ The port has not been initialized yet.
3	H83	Transmission data error	Warning	The parameter value or the number is wrong.
4	H84	Receiving buffer full	Warning	The EH-SIO input buffer is full with receiving data.

Table 6.13 Modbus master mode errors detected in communication

No.	Error code	Item	Error level	Details
1	H8A	Parity error	Warning	EH-SIO detected parity error in response.
2	H8B	Framing error	Warning	EH-SIO detected framing error in response.
3	H8C	Overrun error	Warning	EH-SIO detected overrun error in response.
4	H8D	Check code error	Warning	EH-SIO detected abnormalities in validity of the check code of a response.
5	H8E	Receiving timeout error	Warning	Reception of a response was not completed within the time specified by EH-SIO.
6	H8F	Transmitting timeout error	Warning	EH-SIO did not complete transmission of query within set time interval. (Monitoring time is fixed by the system. It cannot be changed.)
7	H90	Error message response reception	Warning	Error message response was received. (Example: Modbus exception response reception, etc.)
8	H91	Message incorrect	Warning	Received data format is wrong.
9	H92	Query designation error	Warning	Sent data (query) format is wrong.

If exception response is received, error code will be H90. In this case, the exception code (refer to P6-28) is stored in receiving data area.

6.4 Modbus slave mode

In modbus slave mode, EH-SIO responds to a query from master according to modbus protocol. Since operation from receiving a query to sending a response is automatic, no other program is necessary than initial setting.

6.4.1 Overview

EH-SIO gets ready to receive a query after initial setting completed.

When EH-SIO receives a query from external device, EH-SIO analyzes the query and send a command to EH-CPU .

When EH-SIO receives a response from EH-CPU, EH-SIO converts the message to Modbus protocol and send to the external device.

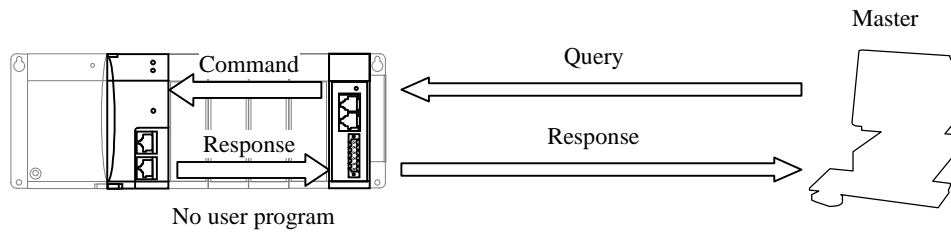

Figure 6.49 Overview of Modbus slave mode

■ Supported function code

Supported function code and the meanings of EH-SIO is shown below.

Table 6.14 Supported function and meanings

Function	Function	
	Modbus Original	corresponding Hitachi I/O
01 (0x01)	Read Coil Status	Read continuous n points of bit output "Y"
02 (0x02)	Read Input Status	Read continuous n points of bit input "X"
03 (0x03)	Read Holding Registers	Read continuous n points of internal register "WR"
04 (0x04)	Read Input Registers	Read continuous n points of internal register "WM"
05 (0x05)	Force Single Coil	Write bit output "Y"
06 (0x06)	Preset Single Register	Write word internal output "WM"
15 (0x0F)	Force Multiple Coils	Write continuous n point of bit output "Y"
16 (0x10)	Preset Multiple Registers	Write continuous n points of internal register "WR"

■ I/O mapping function

The I/O mapping function was supported from software Ver.2.0.

If an I/O mapping function is used, arbitrary I/O classification and addresses can be assigned to the address to H0000 - HFFFF. (The table after address translation is called mapping table.)

Two mapping tables (for bits, for words) can be set up.

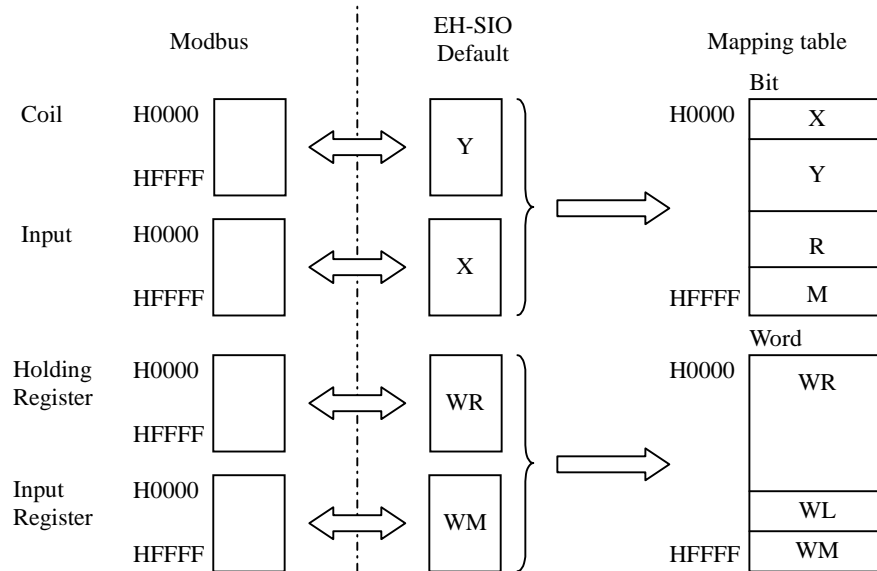

Figure 6.50 I/O mapping image

« Note »

Be careful of the following point at the time of I/O mapping functional use.

- ◆ The function codes 01 (Read Coil Status) and 02 (Read Input Status) turn into a code of the same purpose.
- ◆ The function codes 03 (Read Holding Registers) and 04 (Read Input Registers) turn into a code of the same purpose.
- ◆ An input (Input) and an output (Coil) are intermingled in an address H0000 - HFFFF. The set to an input and a N continuation set come be made, the data set to the input is updated by the actual input value by I/O refreshment.
- ◆ N continuation read or N continuation set cannot be performed ranging over I/O from which classification differs.

📖 Reference : Merit / demerit of the I/O mapping

(1) Merit

Since I/O which can be accessed in function code was decided as shown in Table 6.14, EH-SIO cannot be accessed at I/O which does not correspond to a function code.

Moreover, although the address of I/O is specified by 1-word data (H0000 - HFFFF) in a Modbus protocol, since the number of the addresses of remote I/O of EH-150 is five, they cannot be accessed by the Modbus protocol.

These problems are solved by using an I/O mapping function.

(2) Demerit

Since I/O of two or more classification is made intermingled in an address H0000 - HFFFF, a user needs to manage the assigned address. A host has to send query conscious of I/O mapping.

Ex.) When WR0 is mapped in H8000 → For accessing WR2000, it is specified as an address HA000.

■ Error detection

(1) EH-SIO hardware error

When EH-SIO detects serious error, operation is stopped. Try to push reset button in front panel or reboot the power.

(2) Query error

When EH-SIO detects communication error (parity error, check code error, etc) or in received query, error code will be stored, and the response will not be sent out. Since EH-SIO keeps operation, rebooting or resetting is not necessary.

« Note »

EH-SIO does not send a response in case of error. Be sure to make fail-safe system like timeout in master side if necessary.

(3) Exception response

If the slave receives the query without a communication error, but cannot handle it (for example, if the request is to read a non-existent coil or register), the EH-SIO will return an exception response informing the master of the nature of the error and keep operation. So rebooting or necessary is not necessary.

6.4.2 User project structure

Following user project structure is required in case of usage of Modbus slave mode of EH-SIO.

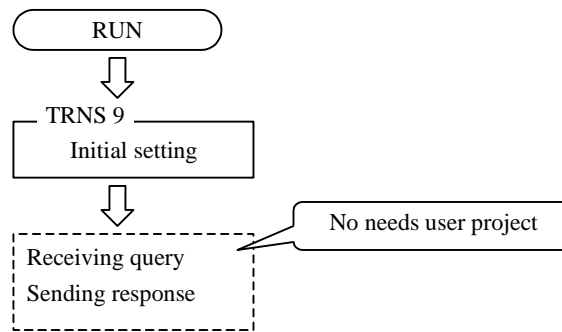

Figure 6.51 User project structure (Modbus slave)

[STEP 1]

To configure communication port of EH-SIO as Modbus slave mode by using TRNS9 command.

EH-SIO will operate automatically by completion of initial setting of Modbus slave mode. Specific user program is not required to make communication.

Once EH-SIO specified Modbus slave mode, even if EH-CPU stop operation has been done, EH-SIO continues Modbus communication. To stop this operation of EH-SIO, Reset operation of EH-SIO is required.

Regarding initial setting, detailed explanation are shown in subsequent paragraphs.

6.4.3 Initial setting

EH-SIO becomes idle status (waiting to be initial setting by EH-CPU) after power ON.

In modbus slave mode, EH-SIO works while EH-CPU in stop mode. Communication mode is cleared by reset button or rebooting the power.

« Note »

EH-SIO will not receive any operation command from EH-CPU or external device before initial setting.

■ Parameters for initial setting

Table 6.15 Parameter table for initial setting

No.	Parameter	Description
1	Operation mode	Set Modbus slave mode (H0011)
2	Modbus mode	Select ASCII mode or RTU mode Note : Only RTU mode is available in Ver.1.0
3	Node number	Set node number (station number)
4	Waiting time	Waiting time from receiving a query to sending response.
5	I/O mapping information (Bit)	Please specify, when you assign a coil (bit data) to I/O other than a default. * The I/O mapping function has not been supported in Ver.1.00. Set H0000 in Ver. 1.0
6	I/O mapping information (Word)	Please specify, when you assign a register (word data) to I/O other than a default. * The I/O mapping function has not been supported in Ver.1.00. Set H0000 in Ver. 1.0

■ Parameter of TRNS 9 command for initial setting

Command number of initial setting in s+7 is H0000

Be sure to set parameters in the sent data area (s+9 to s+A) according to the next page, and be sure to set dummy parameter in the receiving data area (s+B to s+D) although nothing is stored in the configured address area.

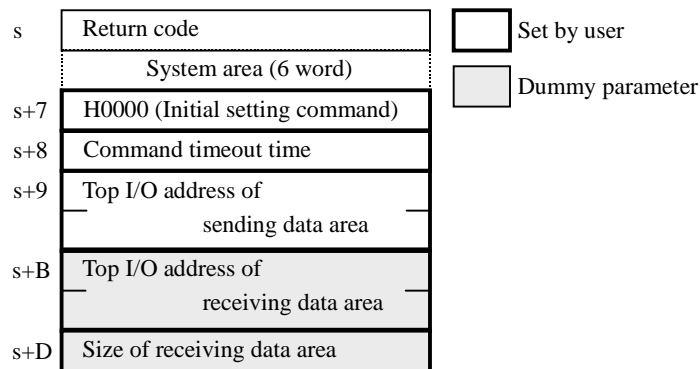

Figure 6.52 s parameter format (Modbus slave / Initial setting)

■ Sending data area for initial setting

Parameter table for the sending data area (s+9, s+A) is as follows.

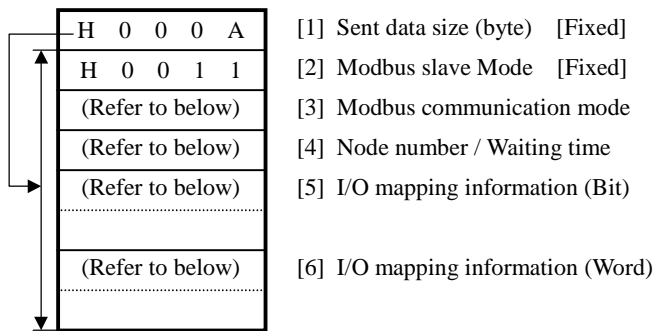

Figure 6.53 Sending data area format (Modbus slave / Initial setting)

Meaning of each parameter described as follows.

[1] Sent data size (byte)

The number of data transmitted to EH-SIO is specified.

The number of transmission data changes with setup of I/O mapping information. When you do not use I/O mapping (use default setting), the number of transmission data should set to 10 bytes (10 / H000A).

« Note »

Software ver.1.0 are not supporting the I/O mapping function. Since the setting parameter in Ver.1.0 is 10 word fixation.

[2] Communication mode

Set H0011 in case of modbus slave mode.

[3] Modbus communication mode

Select modbus ASCII mode or RTU mode.

Table 6.16 Modbus communication mode

Value	Communication mode
H0000	RTU mode
others	ASCII mode (Not supported in Ver. 1.0)

[4] Device address / waiting time



(1) Device address

Set device address in the high byte.

Note : No.00 is not possible to set.

(2) Waiting time [×10ms]

Waiting time is a time between receiving a query and sending a response. Actual waiting time is set time multiplied by 10ms.

Note : The waiting time is the minimum value. It takes longer depending on system processing time of EH-SIO.

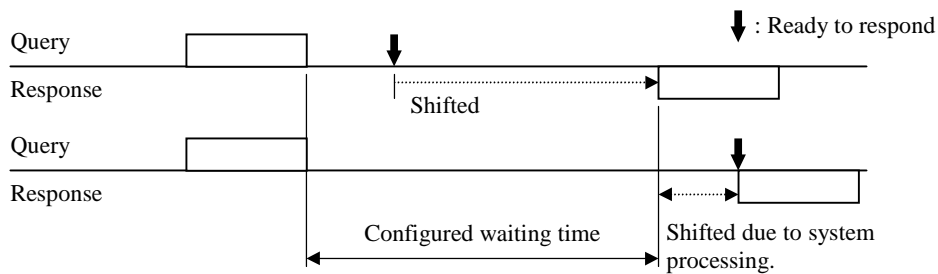
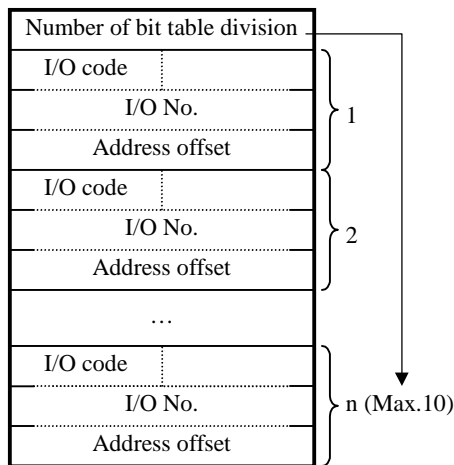

Figure 6.54 Waiting time

[5] I/O Mapping information (Bit)



(1) The number of bit table division (1 word)

The maximum of the number of table division is 10. If a larger value than 10 is set up, it will become an initial setting error.

(2) I/O Code / I/O address (2 word / 1 class)

I/O code is specified from the high byte of 1st word. A top address is specified from low byte of 1st word and 2nd word.

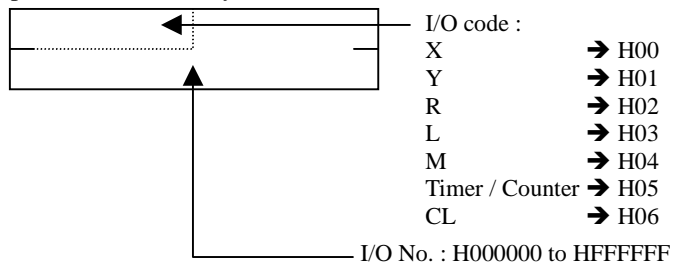

Ex) In case of Y20316 1st word ... H0120, 2nd word ... H0310

(3) Address offset of Modbus protocol (1 word / 1 class)

It specifies where the top address of I/O of (2) is mapped.(H0000 to HFFFF)

« Note »

- ◆ (2), (3) of parameter prepares the number set up with the number of table division.
- ◆ When you use Ver.1.0, or when you do not use I/O mapping, please set the number of bit table division as H0000. When the number of table division is 0, the parameter of I/O classification, I/O No., and address offset is unnecessary.

[6] I/O Mapping information (Word)

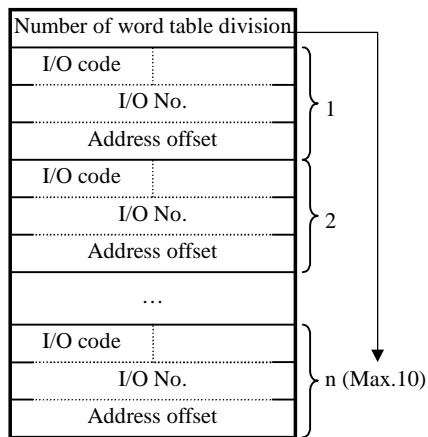

(1) The number of word table division (1 word)

The maximum of the number of table division is 10. If a larger value than 10 is set up, it will become an initial setting error.

(2) I/O Code / I/O address (2 word / 1 class)

I/O code is specified from the high byte of 1st word. A top address is specified from low byte of 1st word and 2nd word.

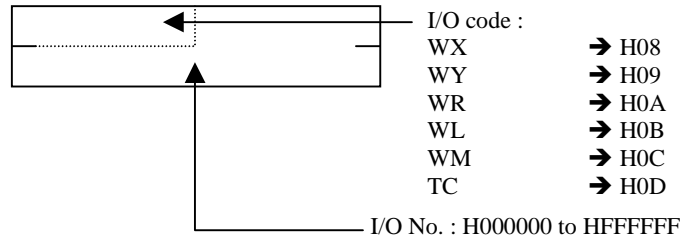

Ex) In case of WRA210 1st word...H0A00, 2nd word...HA210

(3) Address offset of Modbus protocol (1 word / 1 class)

It specifies where the top address of I/O of (2) is mapped.(H0000 to HFFFF)

« Note »

- ◆ (2), (3) of parameter prepares the number set up with the number of table division.
- ◆ When you use Ver.1.0, or when you do not use I/O mapping, please set the number of bit table division as H0000. When the number of table division is 0, the parameter of I/O classification, I/O No., and address offset is unnecessary.

■ Execution of initial setting

Set execution flag (t+0) after s parameter and the sent data area configured.

« Note »

Max. number of modbus slave mode is 8 modules per EH-CPU. (Both ports can work as Modbus slave in 8 modules)

■ Setting completion

(1) Completed properly

H0000 is stored in return code area (s+0), and completion flag(t+1) goes on. A status register XICx and TIIx goes on. Status LED MBx is ON, and LED LNK, HPx and MSx are off.

(x = 1:port 1, 2:port 2)

(2) Error

Error flag (t+2) goes on, and error code will be stored in return code area. Please eliminate the error factor by referring to the return code in section “6.4.4 Error detection in modbus slave mode”

■ Sample program [Initial setting]

(1) Ladder program (Not used I/O mapping function)

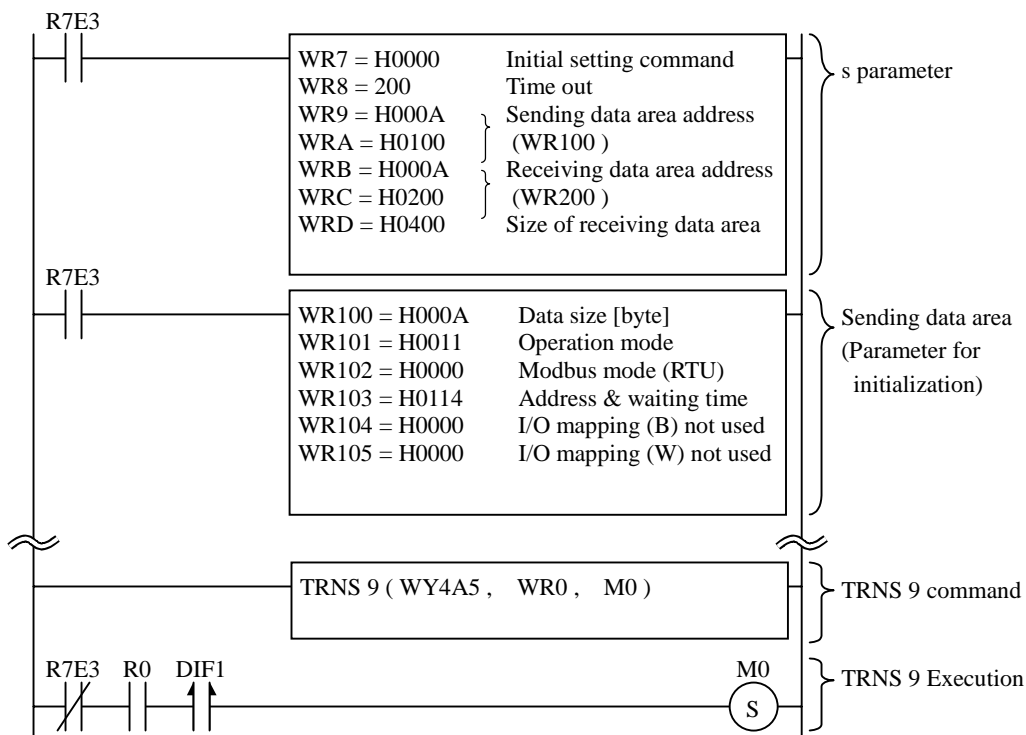

(2) Description of the sample program

s parameters and sent data area are configured at the first scan (R7E3).

When R0 is set ON, TRNS 9 is executed then port 2 in slot A, unit 4 is configured as following table.

Item	Value	Meaning
Communicatino mode	H0011	Modbus slave mode
Modbus mode	H0000	Modbus RTU mode
Device address	H01xx	No. 01
Waiting time	Hxx14	200 ms (20 × 10ms)
I/O mapping (Bit)	H0000	Not used
I/O mapping (Word)	H0004	Not used

(1) Ladder program (word I/O mapping used)

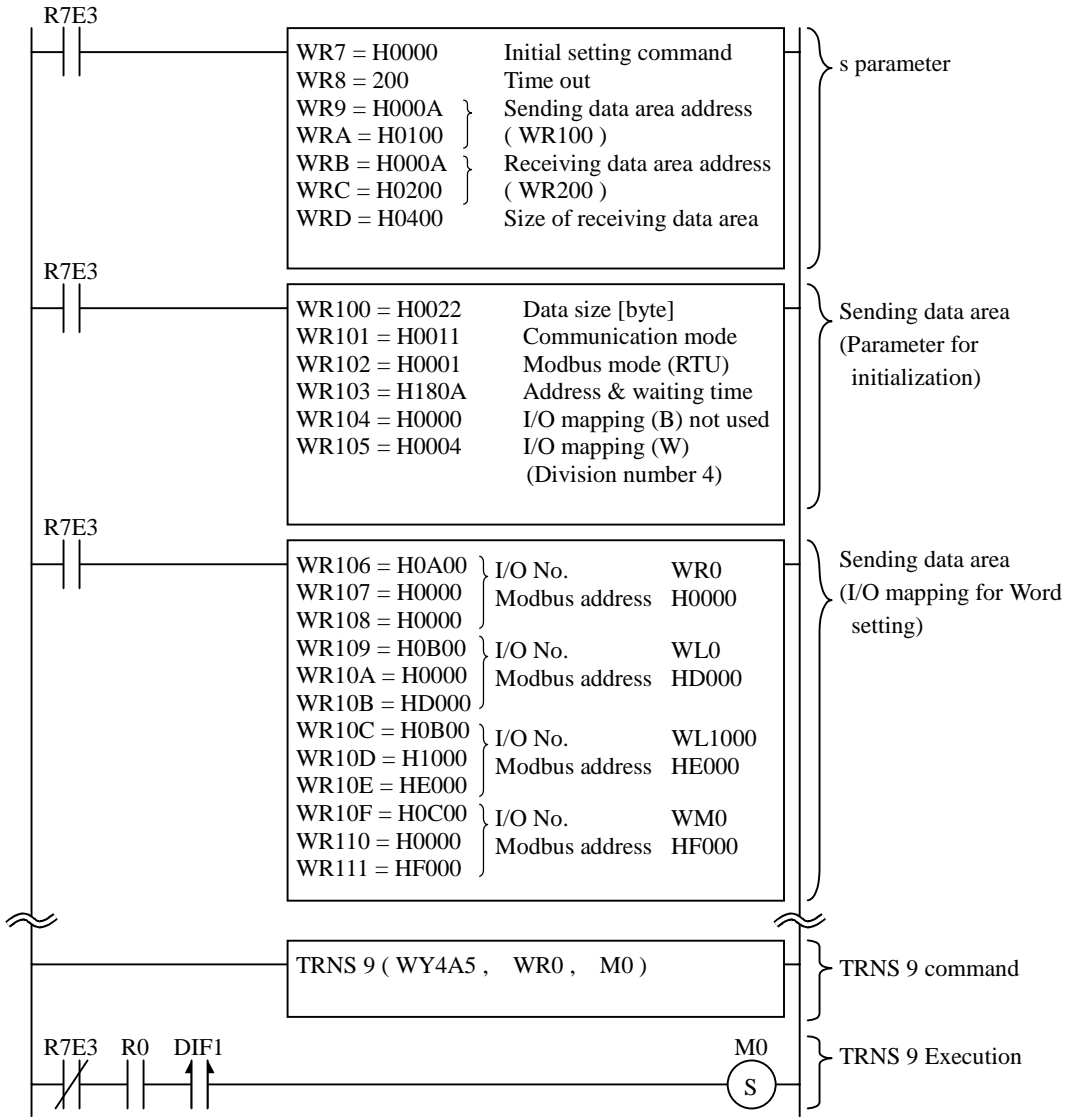

(2) Description of the sample program

s parameters and sent data area are configured at the first scan (R7E3).

When R0 is set ON, TRNS 9 is executed then port 2 in slot A, unit 4 is configured as following table.

Item	Value	Meaning
Communication mode	H0011	Modbus slave mode
Modbus mode	H0001	Modbus ASCII mode
Device address	H18xx	No. 24
Waiting time	Hxx0A	100 ms (10 × 10ms)
I/O mapping (Bit)	H0000	Not used.
I/O mapping (Word)	H0004	Used. The number of table division 4

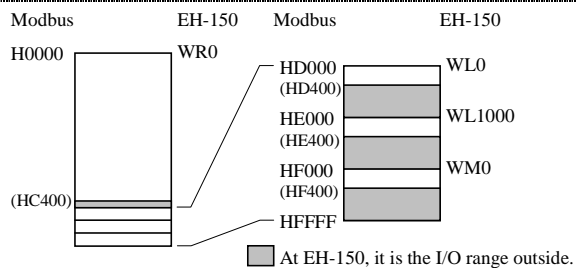

Modbus Slave

6.4.4 Response

All explanation in this section is the responses at the time of a default (I/O mapping not used) setup.

■ **Command 0x01 (Read Coil Status)**

For EH-SIO, this command means “Read status of output (Y)”. Broadcasting is not supported.

(1) Query

The start address of the coil and the number of coils are specified in the query message.

« Note »

It is necessary to change the bit number to hexadecimal number. (When using I/O mapping, the bit No. in a module are hexadecimal number.)

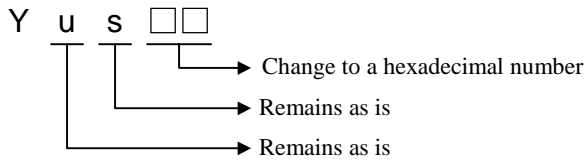

For example, when reading from Y100 (u-0, s-1, and bit No.-00), the start address is H0100. When reading from Y4A10 (u-4, s-A, and bit No.-10), the start address is H4A0A.

(2) Response

Response is sent back automatically according to query. The meaning of the data field bit, with 1 for ON and 0 for OFF, the first LSB data will be in the state of the specified I/O number. Data is handled as 1 byte. If data less than 1 byte is requested, the rest part will be 0.

« Note »

If requested address or a part of data is not assigned as output, exception response will be returned.

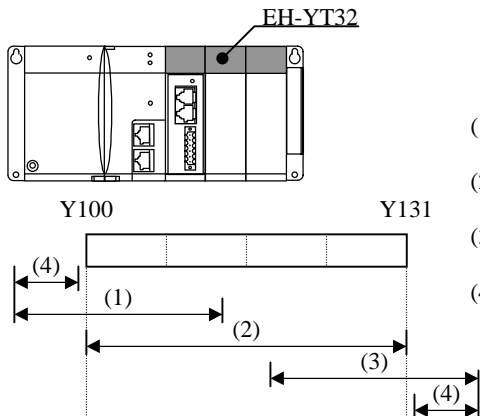

- (1) Set number of bits from outside the I/O No. range to go inside the I/O No. range -- NG
- (2) Set number of bits from inside the I/O No. range to go inside the I/O No. range -- OK
- (3) Set number of bits from inside the I/O No. range to be in excess of the I/O No. range -- NG
- (4) Set area where there is no I/O layout. -- NG

(3) Example

Read the status of Y110-Y123 (14 points) in the slave 03.

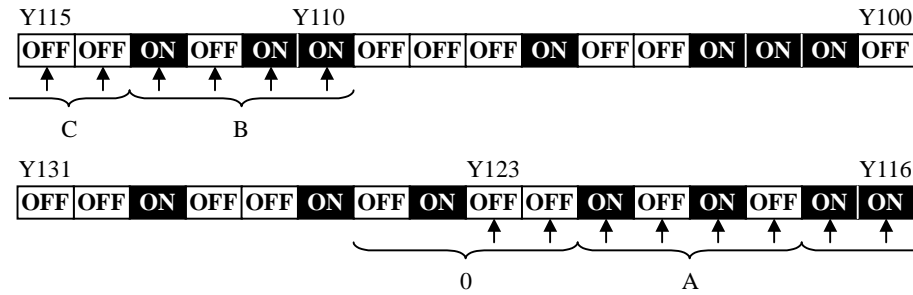

Query	
Field name	Example (HEX)
Slave address	0 3
Function code	0 1
Coil head address (upper)	0 1
Coil head address (lower)	0 A
Number of coils (upper)	0 0
Number of coils (lower)	0 E
Error check	[CRC]

Response	
Field name	Example (HEX)
Slave address	0 3
Function code	0 1
Number of data bytes	0 2
Coil data (upper)	C B
Coil data (lower)	0 A
Error check	[CRC]

Data in Y110 – Y117 is stored in high byte (LSB = Y110), and data in Y118 –Y123 is stored in low byte.

■ Command 0x02 (Read Input Status)

For EH-SIO, this command means “Read status of input (X)”. Broadcasting is not supported.

(1) Query

The start address of the input bit and the number of inputs to be read are specified in the query.

« Note »

It is necessary to change the bit number to hexadecimal number. (When using I/O mapping, the bit No. in a module are hexadecimal number.)

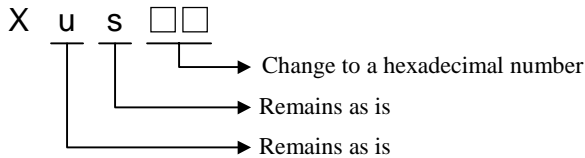

For example, when reading from X1232 (u-1, s-2, and bit No.-32), the start address is set to H1220.

(2) Response

Response is sent back automatically according to query. The meaning of the data field bit, with 1 for ON and 0 for OFF, the first LSB data will be in the state of the specified I/O number. Data is handled as 1 byte. If data less than 1 byte is requested, the rest part will be 0.

« Note »

If requested address or a part of data is not assigned as input, exception response will be returned.

(3) Example

Read the status of X2408-X2415 (8 points) in the slave 05.

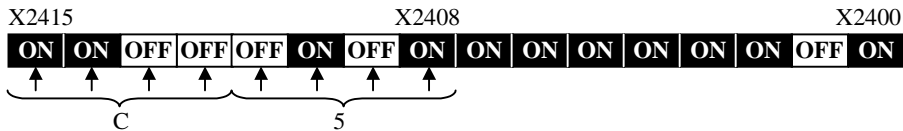

Query	
Field name	Example (HEX)
Slave address	0 5
Function code	0 2
Input status head address (upper)	2 4
Input status head address (lower)	0 8
Input status number (upper)	0 0
Input status number (lower)	0 8
Error check	[CRC]

Response	
Field name	Example (HEX)
Slave address	0 5
Function code	0 2
Number of data bytes	0 1
Input status data	C 5
Error check	[CRC]

Data in X2408 – X2415 is stored in byte (LSB = X2408).

■ Command 0x03 (Read Holding Registers)

For EH-SIO, this command means “Read status of internal output (WR)”. Broadcasting is not supported.

(1) Query

The start address of the internal output (WR) and the number of internal outputs to be read are specified in the query.

« Note »

A start address should specify I/O number of WR. (For WRF000, the address is specified as HF000.)

(2) Response

Response is sent back automatically according to query. Response is returned in an order from the high byte of the specified address.

« Note »

If requested address or a part of data is not assigned as WR range, exception response will be returned.

(3) Example

Read the status of WR9A02-WR9A03 (2-word part) in the slave 10.

WR9A02	H 4 9 2 A	←
WR9A03	H C 1 F 5	←

Query	
Field name	Example (HEX)
Slave address	1 0
Function code	0 3
Maintenance register head address (upper)	9 A
Maintenance register head address (lower)	0 2
Maintenance registers number (upper)	0 0
Maintenance registers number (lower)	0 2
Error check	[CRC]

Response	
Field name	Example (HEX)
Slave address	1 0
Function code	0 3
Number of data bytes	0 4
Maintenance register data 1 (upper)	4 9
Maintenance register data 1 (lower)	2 A
Maintenance register data 2 (upper)	C 1
Maintenance register data 2 (lower)	F 5
Error check	[CRC]

Data of WR9A02-WR9A03 is stored in an order from the high byte.

■ Command 0x04 (Read Input Registers)

For EH-SIO, this command means “Read status of internal output (WM)”. Broadcasting is not supported.

(1) Query

The start address of the internal output (WM) and the number of internal outputs to be read are specified by the query.

« Note »

A start address should specify I/O number of WM. (For WM3F1, the address is specified as H03F1.)

(2) Response

Response is sent back automatically according to query. Response is returned in an order from the high byte of the specified address.

« Note »

If requested address or a part of data is not assigned as WM range, exception response will be returned.

(3) Example

Read the status of WM1F2-WM1F4 (3 word part) in the slave 18.

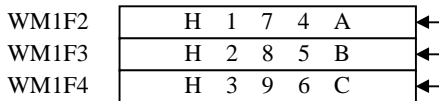

Query	
Field name	Example (HEX)
Slave address	1 8
Function code	0 4
Input register head address (upper)	0 1
Input register head address (lower)	F 2
Input register number (higher rank)	0 0
Input registers number (lower)	0 3
Error check	[CRC]

Response	
Field name	Example (HEX)
Slave address	1 8
Function code	0 4
Number of data bytes	0 6
Input register data 1 (upper)	1 7
Input register data 1 (lower)	4 A
Input register data 2 (upper)	2 8
Input register data 2 (lower)	5 B
Input register data 3 (upper)	3 9
Input register data 3 (lower)	6 C
Error check	[CRC]

Data of WM1F2-WM1F4 is stored in an order from the high byte.

■ Command 0x05 (Force Single Coil)

For EH-SIO, this command means “Write 1 point output (Y)”. In case of broadcasting, the same output in each slave will be written.

(1) Query

The query message data field is H0000 for output ON, and HFF00 for output OFF. In case of a broadcast, please set the slave address field as 00.

« Note »

It is necessary to change the bit number to hexadecimal number. (When using I/O mapping, the bit No. in a module are hexadecimal number.)

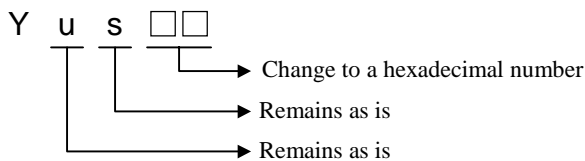

For example, when Y3910 (u-3, s-9, bit No.-10 inside module) is ON, the head address becomes H390A.

(2) Response

When a query is processed normally, the response data will be the same as the query. In broadcasting, no response will be returned.

« Note »

If requested address is not assigned as output, exception response will be returned.

(3) Example

Set Y1021 in the slave 21 to ON.

Query		Response	
Field name	Example (HEX)	Field name	Example (HEX)
Slave address	2 1	Slave address	2 1
Function code	0 5	Function code	0 5
Coil head address (upper)	1 0	Coil head address (upper)	1 0
Coil head address (lower)	1 5	Coil head address (lower)	2 1
Change data (upper)	F F	Change data (upper)	F F
Change data (lower)	0 0	Change data (lower)	0 0
Error check	[CRC]	Error check	[CRC]

When a query is executed properly, the response and the query become the same.

■ Command 0x06 (Preset Single Register)

For EH-SIO, this command means “Write 1 word of internal output (WM)”. In case of broadcasting, the same output in each slave will be written.

(1) Query

The query message data field is the value to change. In case of a broadcast, please set the slave address field as 00.

« Note »

A start address should specify I/O number of WM. (For WM20, the address is specified as H0020.)

(2) Response

When a query is processed normally, the response and the query become the same. In broadcasting, a response is not returned.

« Note »

If requested address is not assigned as internal output, exception response will be returned.

(3) Example

Write H19CF to WMA2 in the slave 27.

Query		Response	
Field name	Example (HEX)	Field name	Example (HEX)
Slave address	2 7	Slave address	2 7
Function code	0 6	Function code	0 6
Register head address (upper)	0 0	Register head address (upper)	0 0
Register head address (lower)	A 2	Register head address (lower)	A 2
Change data (upper)	1 9	Change data (upper)	1 9
Change data (lower)	C F	Change data (lower)	C F
Error check	[CRC]	Error check	[CRC]

When a query is executed properly, the response and the query become the same.

■ Command 0x0F (Force Multiple Coils)

For EH-SIO, this command means “Write multiple outputs (Y)”. In case of broadcasting, the same output in each slave will be written.

(1) Query

Please make the data field for the status of I/O number. Bit meaning 1 is ON and 0 is OFF. Data is handled as 1 byte. If data less than 1 byte is specified, set 0 to the rest area. In case of broadcasting, please set the slave address as 00.

« Note »

It is necessary to change the bit number to hexadecimal number. (When using I/O mapping, the bit No. in a module are hexadecimal number.)

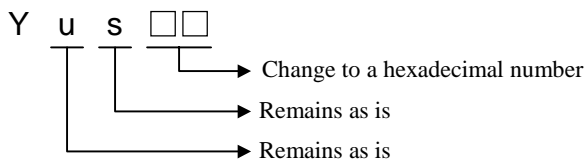

For example, when writing from Y720 (u-0, s-7, bit No. -20 inside module), the start address is set to H0714.

(2) Response

When the query is processed normally, the response data will be the same as the query. In broadcasting, no response will be returned.

« Note »

If requested address is not assigned as output, exception response will be returned.

(3) Example

Write following data to Y4A00 – Y4A15 (16 points) in the slave 31.



Query	
Field name	Example (HEX)
Slave address	3 1
Function code	0 F
Coil head address (upper)	4 A
Coil head address (lower)	0 0
Coil number (upper)	0 0
Coil number (lower)	1 0
Number of bytes	0 2
Change data (upper)	2 1
Change data (lower)	4 3
Error check	[CRC]

Response	
Field name	Example (HEX)
Slave address	3 1
Function code	0 F
Coil head address (upper)	4 A
Coil head address (lower)	0 0
Coil (upper)	0 0
Coil number (lower)	1 0
Error check	[CRC]

When the query is executed properly, data that excludes the number of bytes and data area from the query are returned.

■ Command 0x10 (Force Multiple Registers)

For EH-SIO, this command means “Write multiple internal outputs (WR)”. In case of broadcasting, the same internal output in each slave will be written.

(1) Query

Please make the data field for the status of I/O number. At this time, Please make data into the order of a high byte and a low byte. For example, when setting H1234 to an internal output, the row of data becomes the order of H12 and H13. In case of broadcasting, please set the slave address as 00.

« Note »

A start address should specify I/O number of WR. (For WR3094, the address is specified as H3094.)

(2) Response

When the query is processed normally, the response data will be the same as the query. In broadcasting, no response will be returned.

« Note »

If requested address is not assigned as internal output (WR), exception response will be returned.

(3) Example

Write following data to WR100 – WR101 (2 words) in the slave 51.

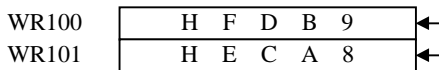

Query	
Field name	Example (HEX)
Slave address	5 1
Function code	1 0
Register head address (upper)	0 1
Register head address (lower)	0 0
Number of registers (upper)	0 0
Number of registers (lower)	0 2
Number of bytes	0 4
Change data 1 (upper)	F D
Change data 1 (lower)	B 9
Change data 2 (upper)	E C
Change data 2 (lower)	A 8
Error check	[CRC]

Response	
Field name	Example (HEX)
Slave address	5 1
Function code	1 0
Register head address (upper)	0 1
Register head address (lower)	0 0
Number of registers (upper)	0 0
Number of registers (lower)	0 2
Error check	[CRC]

When the query is executed properly, data that excludes the number of bytes and data area from the query are returned.

6.4.5 Error detection in modbus slave mode

Since TRNS 9 command is not used in normal operation in case of modbus slave mode, error indication is different from other operation modes.

■ At initial setting

The execution results is shown in t parameter and return code is in s-parameter. If error flag (t+2) of t parameter comes ON after TRNS 9 command execution, some type of error has occurred.

Table 6.17 Modbus slave mode initial setting error list

No.	Error code	Item	Error level	Details
1	HFF	EH-CPU error	---	Operation of EH-SIO stops due to serious error of EH-CPU.
2	---	Watchdog timer error	Serious error	MPU in EH-SIO does not work due to watchdog timer error.
3	H03	OS system error	Serious error	Error is detected in system OS of EH-SIO.
4	H51	Number of entry over	Warning	- Slot number is wrong. - The number of slave function or simple-link function is over the max. number.
5	H81	Command not-supported	Warning	- Command not supported. - Initializing duplicates.
6	H82	Initial setting error	Warning	- Parameter error in initializing - Initializing incomplete

■ While modbus slave operation

Error code is indicated in high byte of status area WXus2, 3. (If error level is warning, EH-SIO keeps working.) If the next query is processed properly, error code in WXus2, 3 is cleared. If TRNS 9 command is issued while modbus slave mode, “Invalid command error (H50)” is given in the return code area of TRNS 9 command.

Table 6.18 Abnormalities during modbus slave mode operation

No.	Error code	Item	Error level	Details
1	HFF	EH-CPU error	---	Operation of EH-SIO stops due to serious error of EH-CPU.
2	---	Watchdog timer error	Serious error	MPU in EH-SIO does not work due to watchdog timer error.
3	H03	OS system error	Serious error	Error is detected in system OS of EH-SIO.
4	H8A	Parity error	Warning	EH-SIO detected a parity error in query (received message).
5	H8B	Framing error	Warning	EH-SIO detected a framing error in query (received message).
6	H8C	Overrun error	Warning	EH-SIO detected an overrun error in query (received message).
7	H8D	Check code error	Warning	EH-SIO detected a validity abnormality in the check code of query (received message).
8	H8E	Receiving timeout error	Warning	Data receiving was not completed with in specified time.
9	H8F	Transmitting timeout error	Warning	Response sending was not completed with in specified time.
10	H91	Query error	Warning	Query (received message) has wrong data

« Note »

Error is checked in every byte. Different from modbus master mode or free protocol mode, only the latest error is indicated in modbus slave mode. So if parity error or framing error is detected, it can be cleared check code error. Please check the transmission code configuration and the transmission speed also in case of check code error.

6.5 Hi-Protocol mode

Hi-Protocol mode is a passive communication mode for EH-SIO. EH-SIO sends response command to a host computer according to the received request command from the host computer. This communication protocol between host computer and EH-SIO is dedicated communication procedure for H and EH series. (A request issued by host computer is called “request task code” and a response sent by EH-SIO is called “response task code”.)

The operation mode is configured by TRNS9 command in user program. Once this mode is configured (initial setting) properly, the other communication program is not required anymore because the system software of EH-SIO will take care this communication operation except initial setting.

« Remark »

As for the communication procedures for H / EH series, there are two procedures, a standard procedure (transmission control procedures 1) and a simple procedure (transmission control procedures 2). EH-SIO software Ver.2.0 is supporting procedures 1 only. EH-SIO of software Ver.2.1 is supporting both of communication procedures.

6.5.1 Basic function

After mode setting (initial setting) is completed, EH-SIO will be the status of “Waiting request task code”.

If EH-SIO receive request task code from host computer, EH-SIO decodes the request task code and transfers the request to EH-CPU. When EH-SIO receives the response from EH-CPU, EH-SIO sends back the response to host computer according to the Hi-Protocol message frame procedure.

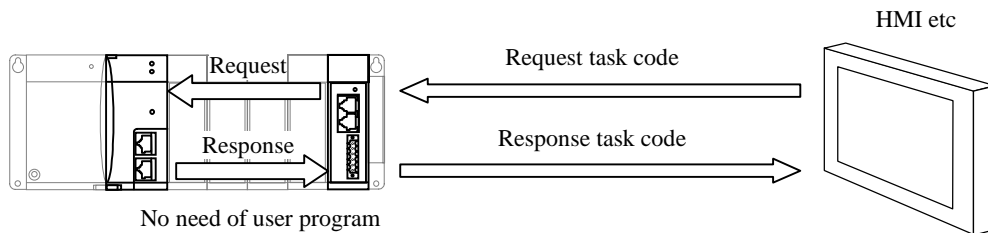

Figure 6.55 Hi-Protocol basic function

■ Table of task code supported by EH-SIO

Following table shows the supported request task code with EH-SIO. The detailed request task code specification are described in “A.3.4 EH-SIO support task code details”

Table 6.19 Supported task code

Command	Contents of function
10H	Read CPU status
16H	CPU occupation / release
17H	Forced release of occupation
40H	Read I/O (series N points) (Read occupation required)
42H	Write I/O (series N points) (Read occupation required)
44H	Read I/O (random N points) (Read occupation required)
45H	Write I/O (random N points) (Read occupation required)
A0H	Read I/O (series N points) (Read occupation not required)
A2H	Write I/O (series N points) (Read occupation not required)
A4H	Read I/O (random N points) (Read occupation not required)
A5H	Write I/O (random N points) (Read occupation not required)

« Note »

Programming softwares and equipments can not operate via EH-SIO even if the communication mode specified Hi-Protocol mode since the special task codes for programming software are not supported by EH-SIO.

■ Error detection

(1) Hardware error of EH-SIO

EH-SIO is able to detect hardware error by self diagnostic. If serious error detected, EH-SIO will stop operation.

In this case, reboot the power or reset EH-SIO by the reset button in front face.

(2) Communication error of a request task code

If EH-SIO detects communication error, such as parity error, checking code error etc., or task code error, such as illegal message frame, illegal parameter of message, EH-SIO will indicate error and send back a response task code with the cause of error.

In case of 1:N communication mode (using station number setting), only the cause of detection of protocol error will be sent and no other error information will be sent back. In these communication error, EH-SIO will continue the operation and will not require power rebooting or resetting.

(3) Task code error for EH-SIO and EH-CPU

In case of no operation possible against requested task code (ex. Nonsupported task code), EH-SIO will send back a response task code with task code error or not-executable task code. In this case EH-SIO will continue the operation and will not require power rebooting or resetting.

Reference : What is Hi-Protocol?

Hi-Protocol is the dedicated communication procedure of H and EH series. A request command issued by host computer is called a request task code, and a response from PLC is called a response task code. In this sense, Hi-Protocol is called Task Code Communication also.

Since PLC status can be monitored and I/O can be read or written, host computer is able to control PLC over network communication by using Hi-Protocol.

The feature of a standard procedure and a simple procedure is as follows.

(1) Standard procedure (transmission control procedure 1)

The module communicates according to the demand from a host, and transmits to a host that response data has been prepared, and response data is returned after that. In addition, by specifying a network address from a host, it can communicate with other CPUs through the CPU link. (Since a network address is own station fixation, EH-SIO cannot communicate with other CPUs.)

(2) Simple procedure (transmission control procedure 2)

A module communicates according to the demand from a host side, and if response data is prepared, it returns a response to a host. Since a network address does not exist in this procedure, it can communicate only between CPUs in which the module is mounted.

6.5.2 Performance

CPU module has two Hi-Protocol processing ports (Port1 and Port2) for each EH-SIO module and handles all requests of one EH-SIO per one time. This means in case of the Hi-Protocol mode usage, the response time will be longer according to the increasing number of EH-SIO, because of the several EH-SIO processing should be done by CPU module sequentially.

The response time of EH-SIO Hi-Protocol mode is shown in below roughly. The figures in this figure are not max. values but just reference.

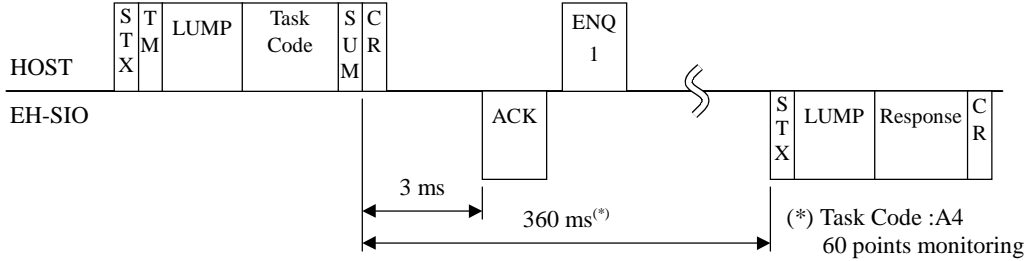

Figuar 6.56 Performance (Transmission control procedure 1)

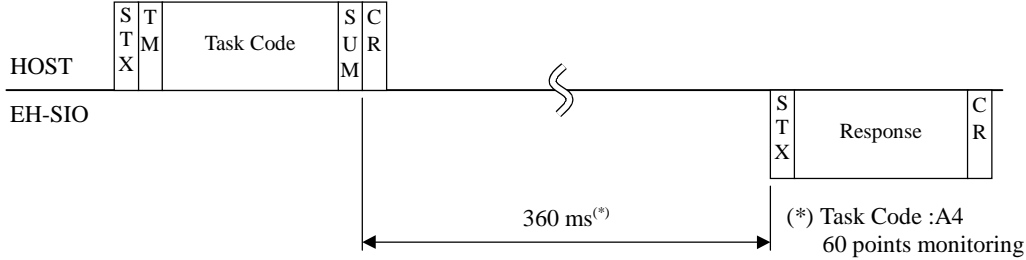

Figuar 6.57 Performance (Transmission control procedure 2)

Reference :

When using several EH-SIOs with Hi-Protocol mode, it is recommended to balance using both port numbers. EH-SIO has two ports (Port1 and Port2). To get better performance using Hi-Protocol, the number of Port1 and Port2 should be same. For exsamble, mounting two EH-SIO modules on base rack and one Hi-Protoocl mode is used each EH-SIO, using Port1 of one EH-SIO and using Port2 of the other EH-SIO is recommended to get better performance.

6.5.3 User project structure

Following user project structure is required in case of usage of Hi-Protocol mode of EH-SIO.

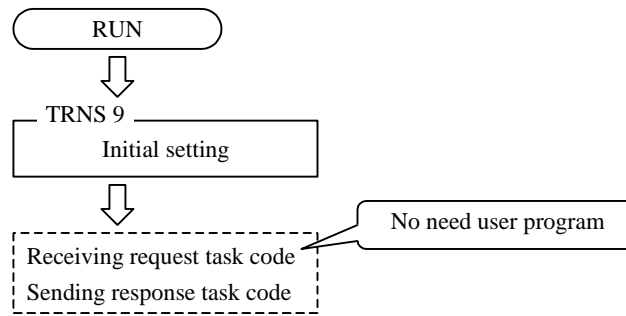

Figure 6.58 User Project structure (Hi-Protocol)

[STEP 1]

To configure communication port of EH-SIO as Hi-Protocol mode by using TRNS9 command.

After initial setting is completed, EH-SIO will operate Hi-protocol mode automatically. Specific user program is not required to make communication.

Once EH-SIO specified Hi-Protocol mode, even if EH-CPU stops operation, EH-SIO continues Hi-Protocol communication. To stop this operation of EH-SIO, Reset operation is required for EH-SIO.

Regarding initial setting, detailed explanation are shown in next section.

6.5.4 Initial setting

After power activated, EH-SIO enters idle status (Waiting initial setting by EH-CPU). Once initialized by EH-CPU, EH-SIO starts Hi-Protocol mode operation.

During Hi-Protocol mode EH-SIO continue this mode even if EH-CPU is in stop mode. To change the operation mode of EH-SIO, power rebooting or reset operation of EH-SIO are requested.

« Note »

EH-SIO will not receive any command from EH-CPU except initial setting command unless initialized. And EH-SIO will not receive any command from connected external device.

■ Needed parameters for initial setting.

Table 6.20 The table of parameter for initial setting

No.	Parameters	Contents
1	Specification of Operating Mode	EH-SIO works according to this Operation Mode. Specify Hi-Protocol Mode
2	Usage of station number	Select usage of task code with station number or without station number.
3	Station number	In case of task code communication with station number, specify station number.

■ Parameters of TRNS9 command for initial setting

Initializing command (specified as s+7) is H0000. Although nothing is stored in the receiving area specified by s+B to s+D, please set paramteres in s+B to s+D.

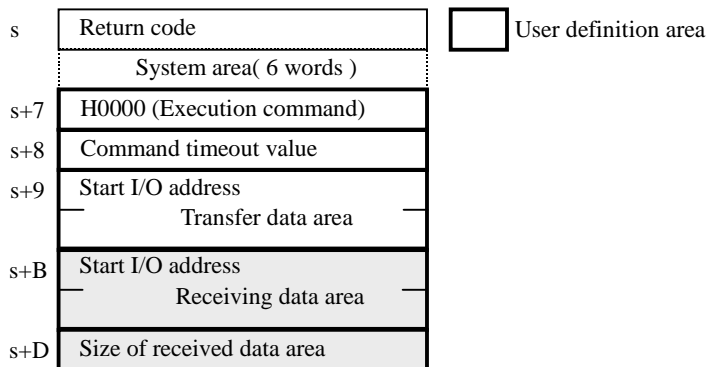

Figure 6.59 Parameters of Hi-Protocol mode initial setting

■ Transfer data area for Initial setting

Parameter structure of sending data area (start address is specified by s+9 and s+A) are shown in below.

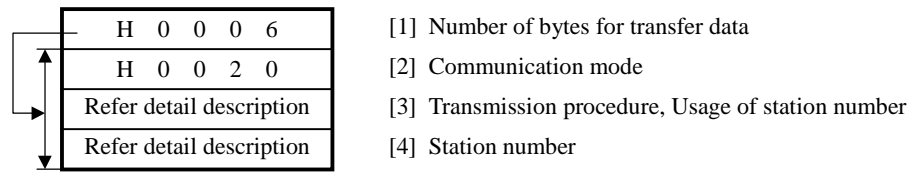

Figure 6.60 Transfer data area for Hi-Protocol mode initial setting

Each meanings and values of parameters are shown in below.

[1] Number of bytes for transfer data

To specify the number of data to transfer EH-SIO from EH-CPU. Six bytes (6 / H0006) is required to set.

[2] Specification of Communication mode.

To specify the communication mode of EH-SIO. H0020 is required to specify Hi-Protocol mode.

[3] Specification of Transmission procedure, Usage of station number.



(1) Transmission control procedure

To specify the communication control procedure.

Table 6.21 Specification of transmission control procedure

Value	Type of task code communication
H00	Standard (Transmission control procedure 1)
H01 - HFF	Simple (Transmission control procedure 2)

(2) Usage of station number

To specify the type of task code communication with station number or without station number.

Table 6.22 Usage of station number

Value	Type of task code communication
H00	Without station number (for 1 : 1 communication usage)
H01 - HFF	With station number (for 1 : N communication)

[4] Station number

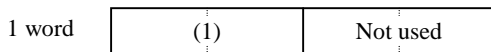

(1) Station number

To specify the station number for communication port with BCD data using upper byte of specified word. The possible data should be less than 31 (H31xx). If the value above 31 (H31xx) is set, initial setting error will be detected. A to F characters are not allowed to use on the station number. If station number includes A to F, initial setting error will be detected too.

(Example) In case of station 18 : H18xx

■ Execution of Initial setting

Set command execution request bit (t+0) ON after storing required data to both s parameter and transfer data area.

« Note »

The maximum number of EH-SIO modules specified as Hi-Protocol mode is 8 with one EH-CPU module.

■ Completion of initial setting

(1) Completed properly

H0000 is stored return code area (s+0) and completion bit (t+1) is turned ON. XICx and TIXx of status register are turned ON, HPx of status LED is turned ON and LNK, MBx and MSx of status LEDs are turned OFF.

(x-1 : port 1, x-2 : port2)

(2) Error

Error bit (t+2) is turned ON and error indication cause code is stored into return code area.

To refer the return code of “6.5.5 Hi-Protocol mode error” and remove the cause of each error.

■ Sample program [initial setting]

(1) Ladder diagram

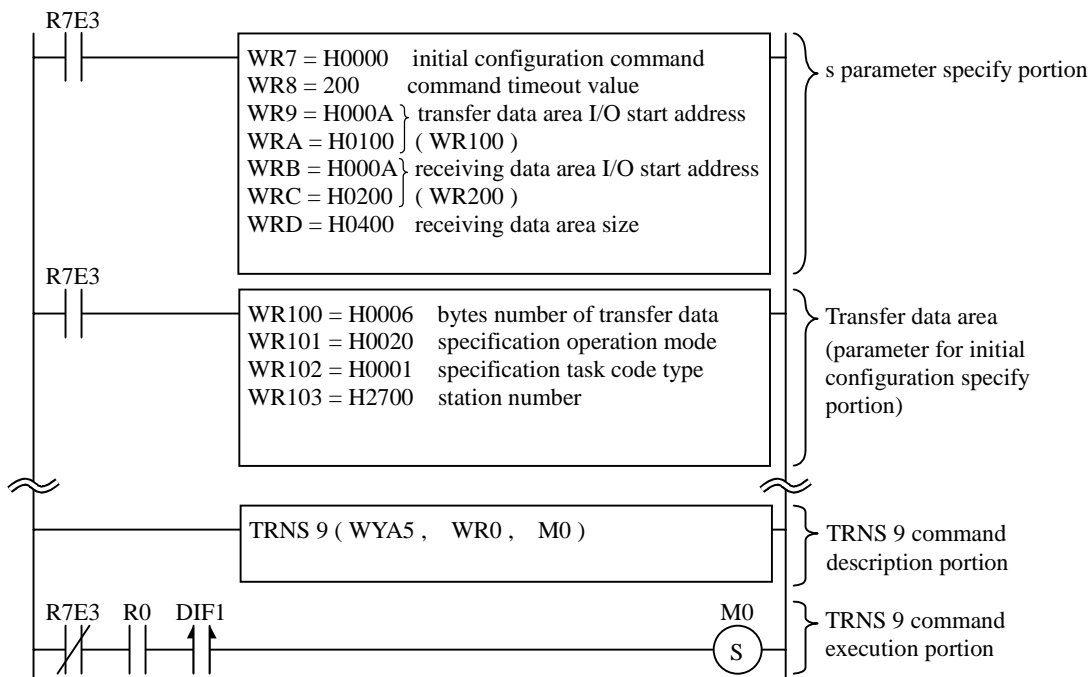

(2) Description of sample program

S parameter and transfer data area are fulfilled at the first scan after power ON.

By setting R0 ON, TRNS 9 is executed and following initial setting shown in below table will be sent to port 2 of EH-SIO module mounted on Unit 0 (basic unit) slot A.

Items	Value	Meaning
Communication mode	H0020	Hi-Protocol mode
Type of task code	H0001	With station number
Station number	H27xx	Station number 27

6.5.5 Error detection in Hi-Protocol mode

The indication method of detected error in Hi-Protocol mode operation is different from the other operation mode. This reason is because of Hi-Protocol mode does not require the TRNS 9 command except initial setting.

■ Error in initial setting

Detail error information can be confirmed by referring the execution result of TRNS 9 command of t parameter, return code of s parameter and data receiving area. In case of error bit (t+2) is turned ON after execution of TRNS 9 command, there is some detected error.

Table 6.23 Hi-Protocol mode initial setting error table

No.	Error Code	Name	Error level	Detail contents
1	HFF	CPU error	---	EH-SIO operation has been stopped due to the error detection of EH-CPU (L.RES ON) was done.
2	---	Watch dog timer error	Fatal Failure	MPU of EH-SIO can't operate according the system program anymore, EH-SIO has detected watch dog timer error of MPU.
3	H03	OS system error	Fatal Failure	EH-SIO has detected an error of system OS.
4	H51	Over flow error of number of specified functions	Warning	There is no EH-SIO mounted, over flow of number of specified functions such as slave function or easy data link function.
5	H81	Non-supported command error	Warning	-Non-supported command by EH-SIO has been specified. -Initial setting is duplicated. (more than twice execution of initial setting)
6	H82	Initial setting error	Warning	-The parameter of initial setting of EH-SIO was illegal. - Initial setting is not completed yet.

■ Error in Hi-Protocol mode

The detected error in Hi-Protocol operation will be indicated in high byte of WX us2 and 3. (The operation will continue if the error level is not serious.) If the next task code is received properly, the error code WX us2 and 3 will be cleared.

If the TRNS command is executed with some missoperation in Hi-Protocol mode, the return code of TRNS 9 command will be “Illegal command specifying error (Error code H50)”.

Table 6.24 Hi-Protocol mode error during operation

No.	Error Code	name	Error level	Detail contents
1	HFF	CPU error	---	EH-SIO operation has been stopped due to the error detection of EH-CPU (L.RES ON) was done.
2	---	Watch dog timer Error	Fatal Failure	MPU of EH-SIO can't operate according the system program anymore, EH-SIO has detected watch dog timer error of MPU.
3	H03	OS system error	Fatal Failure	EH-SIO has detected an error of system OS.
4	H50	Non-valid command error	Warning	TRNS 9 command has been used for the port specified as SLAVE function or easy data link function.
5	H8A	Parity error	Warning	Parity error has been detected in the received data by EH-SIO.
6	H8B	Framing error	Warning	Framing error has been detected in the received data by EH-SIO.
7	H8C	Over run error	Warning	Over run error has been detected in the received data by EH-SIO.
8	H8D	Check code error	Warning	Check code error has been detected in the received data by EH-SIO.
9	H8E	Receiving timeout error	Warning	EH-SIO could not complete the receive operation within the specified time.
10	H8F	Sending timeout error	Warning	EH-SIO could not complete the send operation within the specified time. (the monitoring time interval is fixed and it is not possible to change this time interval.)
11	H91	Receiving Illegal message Contents data	Warning	EH-SIO receives message data including illegal data.

« Note »

EH-SIO is checking parity error and framing error in every byte. In case of Hi-Protocol mode, since only the newest error is indicated, “parity error” and “ framing error” can be overwritten by newest error such as “chek code error”. So, if the “check code error “ is detected, check also transmit character structure and transmit speed.

6.6 Simple data link mode

Simple data link function is established by EH-SIO as a host by sending task codes “Read I/O (series N points) (A0)” and “Write I/O (series N points) (A2)” to other PLC.

The functionality is similar with CPU LINK function, but the data refresh cycle is little bit longer than CPU LINK function because of using serial communication. Advantage is simple data link system can be easily made without other special module required than EH-SIO.

The physical layer of simple data link is RS-422, the protocol is Hi-Protocol (Communication procedure 2) is used. The PLCs (EH-CPU316A / 516 / 548, MICRO-EH 23points or 28points unit) which have these functionality can be connected. Since the link system is handled only by master (EH-SIO), no other setting is necessary on slave PLCs than communication parameter configuration.

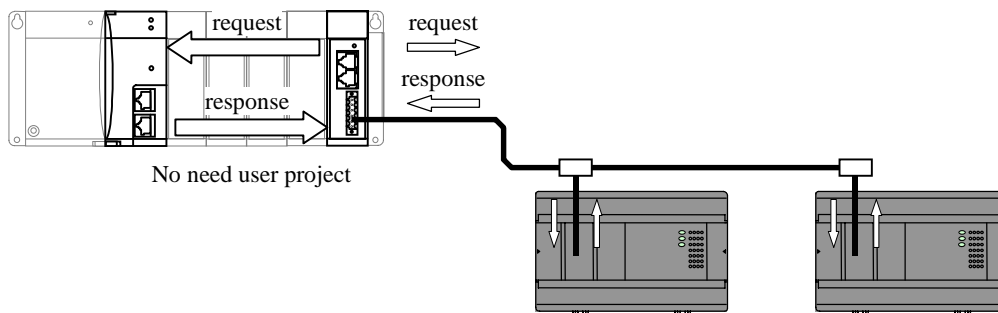

Figure 6.61 Simple data link mode basic operation

« Note »

- ◆ If simple data link mode is configured, port 1 of EH-SIO does not work because of a lot of communication area necessary for EH-SIO.
- ◆ If the initial setting has been completed with port1, simple data link mode can't be configured on port 2.
- ◆ Slave CPU takes part in link system with one port (port 1 for EH-CPU, port 2 for MICRO-EH) fully occupying. So if communication ports of slaves are already used for other purpose, it is impossible to use simple data link function.

6.6.1 Abstract of simple data link

There are two modes for simple data link, the one is standard mode and the other is high speed mode. Standard mode is the mode all link data is shared with master and slave stations. In case of high speed mode, only the link area of master station is shared with slave stations. Since slave data will not be tranfered to the other slaves in case of high speed mode, the refresh time is shorter than standard mode.

■ Standard link mode

The member of slaves and data link area is registered by initial setting.

EH-SIO operate according to the following steps.

- (1) Master reads own writing area.
- (2) Master sends the data to the other slave units one by one.
- (3) Master reads slave A's writing area.
- (4) Master sends the data to other slaves than A one by one.
- (5) Master writes the data to A's area in the master module.
- (6) Master repeats (3) to (5) procedure according to the registered slave station number, and repeats (1) to (6)..

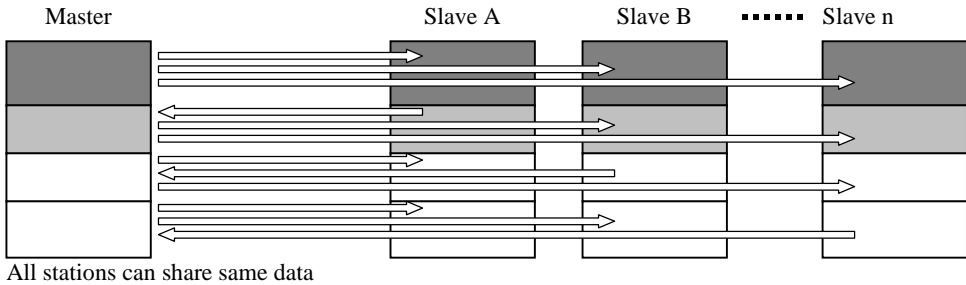

Figure 6.62 Link area image of Standard mode

■ High speed link mode

The member of slaves and data link area is registered by initial setting.

EH-SIO operate according to the following steps.

- (1) Master reads own writing area.
- (2) Master sends the data to the other slave units one by one.
- (3) Master reads slave A's writing area.
- (4) Master writes the data to A's area in the master module.
- (5) Master repeats (3) to (4) procedure according to the registered slave station number, and repeats (1) to (5).

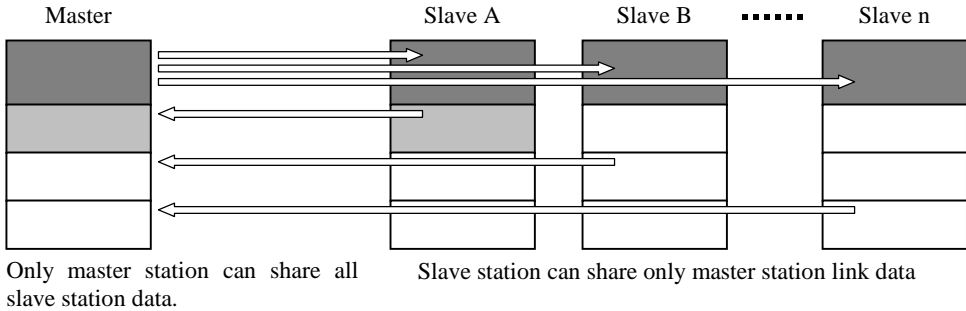

Figure 6.63 Link area image of High speed mode

Simple data link

■ Check link entry status

First two words of master's writing area indicates the link entry status of slaves both for standard and high speed mode. Since the status is updated with link data, it takes a time to update the status data.

The contents of link entry status is shown in Figure 6.63.

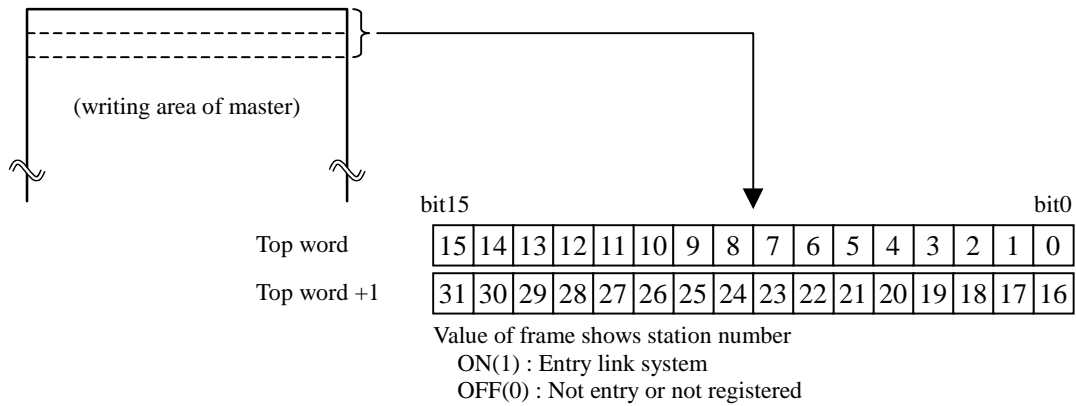

Figure 6.64 Indication of Data link status

Ex.) Registered slave : No. 1, 2, 3, 4, 10, 11, 12, 20, 21, 30

Entry link : No. 1, 2, 3, 4, 10, 21, 30 (No response from No.11 and 20)

Indication of member status start word is H041F (0000 0100 0001 1111)

Start word+1 is H4020 (0100 0000 0010 0000)

■ Error detection

(1) Hardware error of EH-SIO

The operation of EH-SIO is stopped when the self diagnostic of EH-SIO detects hardware error. In this case the operation of data link functionality is stopped and all refresh operation of data link is stopped aslo.

If hardware error is detected, reboot the PLC power or push reset switch of EH-SIO on front panel to restart. It is not required to reboot the power for each slave unit.

(2) Communication error

If EH-SIO detects communication error (parity error or check code error) or does not receive response, indicates error with showing slave station nummber. (EH-CPU will turned off entry flag of error station.)

In this case, EH-SIO will not resend the request command to slave station with error and jump to next slave station. When the next station responses properly, error code will be cleared. In the next cycle, EH-SIO sends the request to all registered stations. If correct response returns from error station, then commun will recover automatically.

Simple data link

6.6.2 Performance specification

Following table shows the performance specification of simple data link.

Table 6.25 Performance specification of simple data link

Items		Specification
Interface		RS-422
Maximum number of link communication		31 stations
Transmission cable length		500m / 250m ^{(*)1}
Number of link points	Per one station	Max. 48 words
	Total stations	Max. 1,536 words
Data exchange method	Between EH-SIO and EH-CPU	Handshaking between CPU module and EH-SIO ^{(*)2}
	Between EH-SIO and slave PLC	Set/reset by using task code communication
Configuration of data area		By Master EH-CPU using TRNS9 command (No configuration necessary for slave stations)
Transmission speed		4,800, 9,600, 19,200 or 38,400 bps ^{(*)3}
Communication Protocol		H series dedicated procedure (Hi-Protocol) Transmission procedure 2
Maximum mounted EH-SIO per CPU		8 units

*1 In case of simple data link communication between EH-150 CPU, maximum length is 500m and in case of MICRO-EH is 250m.

*2 Handshaking between CPU and EH-SIO will be done automatically by system software at the end of scan. It takes 6 scan cycle time to transfer one station data.

*3 Transmission speed is configured by dip switches.

■ Data refresh time

Data refresh time depends on scan time of master CPU, transmission speed, number of slave stations and size of data link area. Following is the formula of data refreshing time.

(1) Standard mode

$$\{ RReq + RRes + (WReq + WRes) \times n + SWT \times n + RWT \times n + HST \} \times n$$

- n : number of station
- RReq : transmission time of reading request from master to slave (depends on transmission speed)
- RRes : transmission time of reading response from slave to master (depends on capacity and transmission speed)
- WReq : transmission time of writing request from master to slave (depends on capacity and transmission speed)
- WRes : transmission time of writing response from slave to master (depends on transmission speed)
- SWT : switching time from one slave to other slave station number (configured by user)
- RWT : slave station response time delay (configured by user)
- HST : handshake time between EH-CPU and EH-SIO (6 times of scan time)

Ex.) Number of stations : 31 stations, 48 words, Transmission speed : 38.4kbps, Switching slave time : 20ms, waiting time of slave response : 20ms, CPU scan time : 10ms

$$\{ 5 + 52 + (55 + 2) \times 31 + 20 \times 31 + 20 \times 31 + 60 \} \times 31 = 96844 \text{ [ms]} = 96.8 \text{ [s]}$$

(2) High speed mode

$$(RReq + RRes + WReq + WRes + SWT + RWT + HST) \times n$$

Ex.) Number of stations : 31 stations, 48 words, Transmission speed : 38.4kbps, Switching slave time : 20ms, waiting time of slave response : 20ms, CPU scan time : 10ms

* The simple data link communication can continue even if the EH-CPU status is in STOP. In this case, CPU scan time should be calculated as 120ms.

6.6.3 User project structure

Following user project structure is required in case of usage of simple data link mode of EH-SIO.

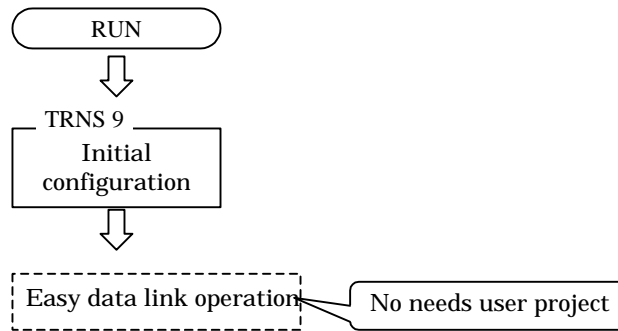

Figure 6.65 User Project structure (Simple data link)

[STEP 1]

Configure communication port of EH-SIO as simple data link mode by using TRNS 9 command .

EH-SIO will operate automatically after initial setting completed. No other user program is necessary than initial setting.

Once EH-SIO specified simple data link mode, even if EH-CPU is in stop mode, EH-SIO continues simple data link communication. To stop this operation of EH-SIO, reset operation of EH-SIO is required.

Go on to the next section for further information about initial setting.

6.6.4 Master configuration (Initial setting of EH-SIO)

EH-SIO must be configured as simple data link mode by initial setting. (This is same as other configuration, TRNS 9 command is required for EH-SIO initial setting.) EH-SIO starts simple data link operation after initial setting. Once initial setting is completed, EH-SIO continues simple data link operation even if EH-CPU is in stop mode. To change the operation mode of EH-SIO, reboot the power or reset EH-SIO.

« Note »

EH-SIO will not receive any command from EH-CPU except initial setting command unless initial setting completed.

■ Needed parameters for initial setting

Table 6.26 The table of parameter for initial device,

No.	Parameters	Contents
1	Specification of Operating Mode	EH-SIO operation depends on selected operation mode. Configure parameters for simple data link mode.
2	Waiting time of slave response	Specify waiting time for slave response.
3	Waiting time between stations	Specify waiting time between stations.
4	Setting of data link area	Specify internal output I/O type and start address of data link operation.
5	Number of words occupied by master	Specify data size (word) for master station.
6	Number of station and words number of each station	Specify station number of slaves and data size (word).

■ s Parameters of TRNS 9 for initial setting

Initializing command (specified as s+7) is H0000. Although nothing is stored in the receiving area specified by s+B to s+D, please set paramteres in s+B to s+D.

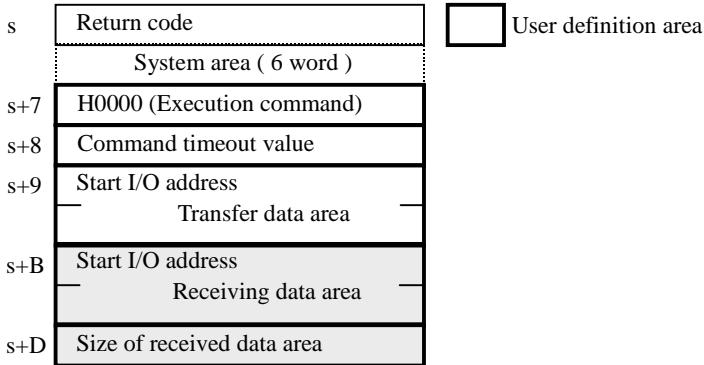

Figure 6.66 s Parameters of simple data link mode initial setting

■ Transfer data area for Initial setting

Parameter structure of transfer data area (start address is specified by s+9 and s+A) are shown in below.

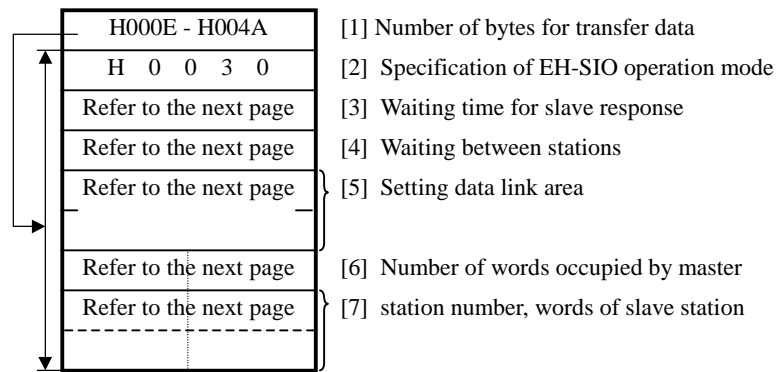

Figure 6.67 Transfer data area for simple data link mode initial setting

Each meanings and values of parameters are shown in below.

[1] Number of bytes for transfer data

Specify the number of data transfer EH-SIO from EH-CPU. This is the number of bytes from [2] to [7], which depends on number of slave stations.

[2] Specification of EH-SIO operation mode

Specify H30 for simple data link mode.

[3] Waiting time for slave response

Waiting time for slave response is the time from receiving request to sending response. Slave station will wait specified time multiplied by 10ms, and reply to EH-SIO.

The possible value for configuration is 0 (no wait time) to 15(H000F) (waiting 150ms), and if the set value is out of this range, initial setting error will be detected.

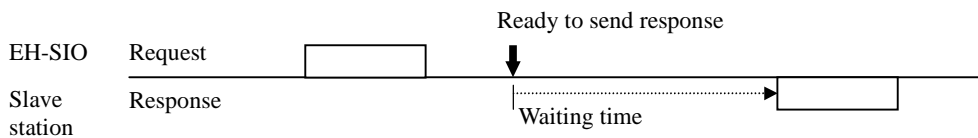

Figure 6.68 Waiting time for slave response

« Note »

This parameter is recommended to be configured as 20 ms or more for stable communication.

Simple data link

[4] Waiting time between stations

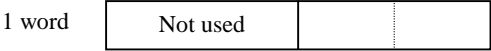

EH-SIO sends a command to each station one by one. Interval time between stations can be configurable. EH-SIO will wait specified time multiplied by 10ms and sends response to next slave station. The possible value for configuration is from 0 to 255 (H00FF). Data in high is ignored.

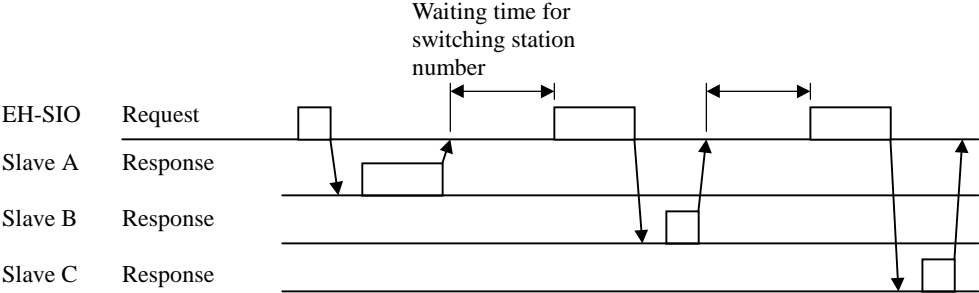
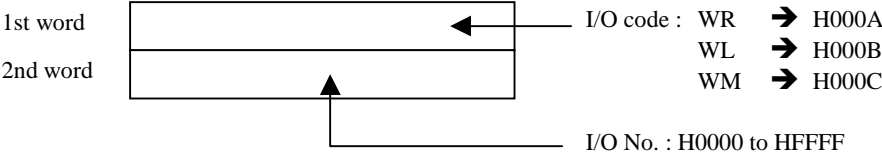

Figure 6.69 Waiting time between stations

[6] Setting data link area



I/O type and address is configured by 2 words. This address will be the starting address of data link area. (same both for Master and Slave station.)

Ex.) Incase of WRA00 should be start address → 1st word : H000A
2nd word : H0A00

[7] Number of words for master

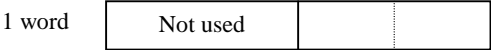

Specify the data size of master in BCD. Valid range is H02 to H48. If the value is less than H1 or more than H49 or including A to F characters, initial setting error will be detected.

Simple data link

[8] Station number, words of slave station

One word for one station. Specify as many words as slave station number.

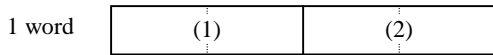

(1) Station number

Specify station number in high byte in BCD.

The valid range is from H01 to H31. If the value is 0 or more than H32 or including A to F characters, the initial setting error will be detected.

(2) Number of words for slave station

Specify the data size of slave station in low byte in BCD.

The valid range is H00 to H48. If the value is more than H49 or including A to F characters, the initial setting error will be detected.

Ex.) In case of station number 01(16 words), station number 14(4 words) and station number 29(32 words) make data link.

- ➔ 1st word : H0116
- 2nd word : H1404
- 3rd word : H2932

With above configuration, data table is as follows.

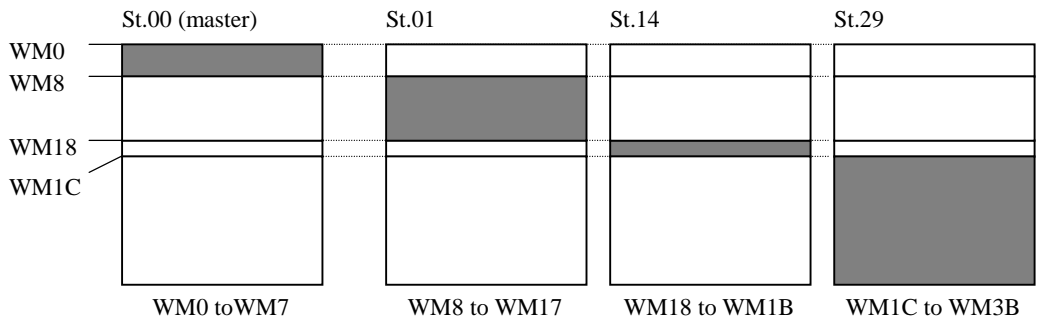

Simple data link

■ Execution of Initial setting

Set command execution request bit (t+0) ON after storing required data to both s parameter and transfer data area.

■ Completion of Initial setting

(1) Completed properly

H0000 is stored return code area (s+0) and completion bit (t+1) is turned ON. XIC2 and TH2 of status register are turned ON, LNK of status LED is turned ON and MB2, HP2 and MS2 of status LEDs are turned OFF.

(2) Error

Error bit (t+2) is turned ON and error indication cause code is stored into return code area.

To refer the return code of “6.5.6 Simple data link mode error” and remove the cause of each error.

■ Sample program [Initial setting]

(1) Ladder diagram

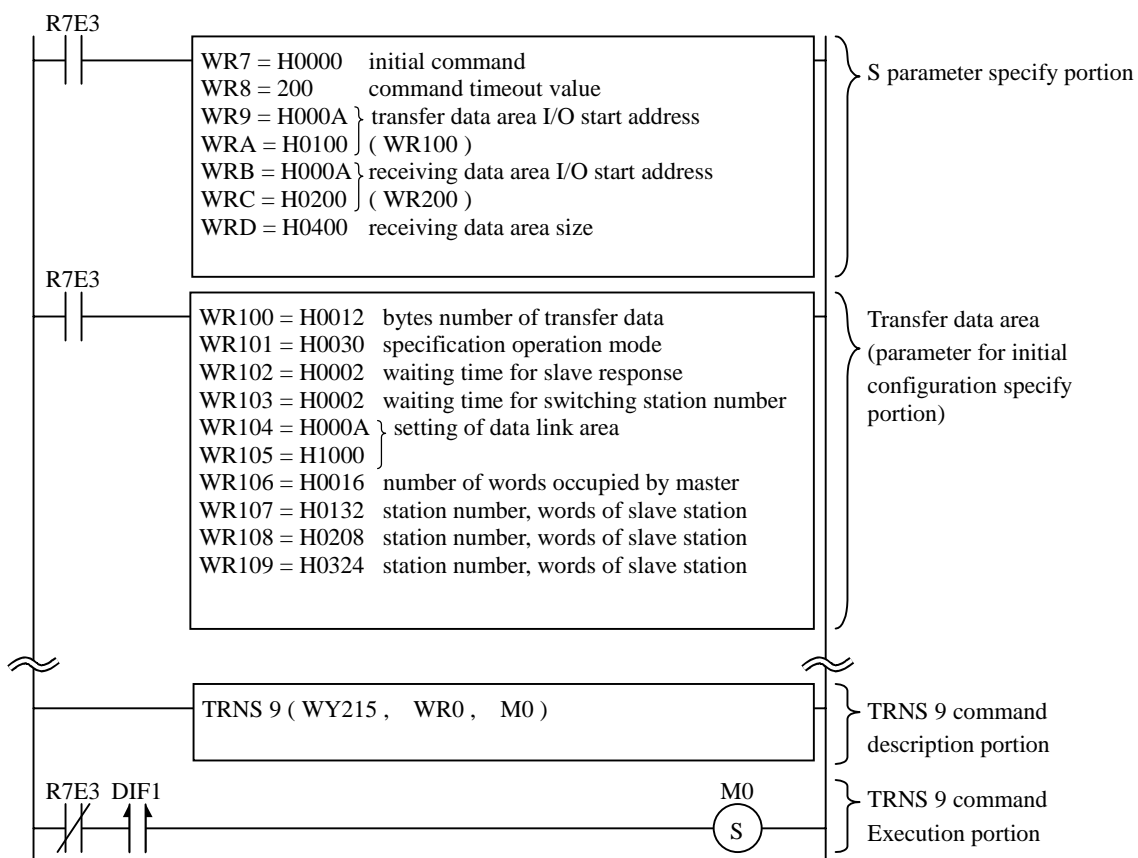

(2) Description of sample program

S parameter and transfer data area are fulfilled at the first scan after power ON.

At the second scan, TRNS 9 command is executed and following initial setting shown in below table will be sent to port 2 of EH-SIO module mounted on Unit 0 (basic unit) slot 1.

Items	Set value	Configuration
Communication mode	H0030	Simple data link mode (standard)
Waiting time for slave response	H0002	20 ms (2 x 10ms)
Waiting time for switching station number	H0002	20 ms (2 x 10ms)
Setting data link area	H000A H1000	Specify WR1000
Number of words occupied by master	H0016	16 words (WR1000 to WR100F)
Station number, words of slave station	H0132	Station number01, 32words (WR1010 to WR102F)
	H0208	Station number02, 8words (WR1030 to WR1037)
	H0324	Station number03, 24words (WR1038 to WR105F)

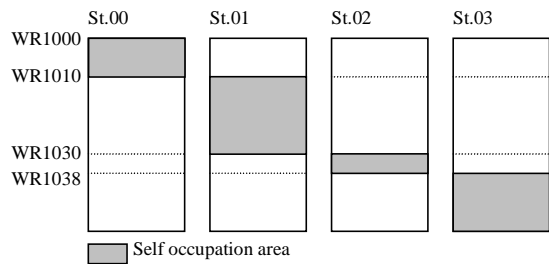

6.6.5 Configuration of slave station

(1) In case of EH-CPU as slave station

Configure port 1 of EH-CPU as RS-422 transmission procedure 2 with station number.

Step 1 : Set DipSwitch of EH-CPU at the bottom according to transmission speed of EH-SIO.

Step 2 : Set parameter in special internal output WRF037 according to the table 6.26.

Table 6.27 Configuration of EH-CPU communication port

WRF037			Interface
User value	System value ^{*1}	Indication after power up	
HE1**	H61**	H65**	RS-422 Internal terminator register is ^{*2} is OFF
HF1**	H71**	H75**	RS-422 Internal terminator register ^{*2} is ON

** : To mean the station number during 1:N communication. Two digits of 00 to 31 with BCD value. To specify 00 to 31 with BCD two digits. If the value is out of range, the same value will be displayed but the forced station number 31 will be used for this operation.

*1 b11 and b10 of WRF037 indicates current interface status. Therefore depends on the last setting, different value may be displayed as system value. To refer the instruction manual to know each bits contents of WRF037.

*2 Built-in termination resistor is supported only by CPU516/548. In case of internal terminator register is ON, it is no need to put external termination register because if the 100 ohm register is connected internally. (Be careful some model dose not have internal termination register. Please refer the instruction manual to know more detail information.)

« Note »

- ◆ CPU which dose not have both RS-422 and transmission procedure 2 can't be used as slave station.
- ◆ Implement wiring according to the interface of RS-422.
- ◆ It is possible to use RS-485 instead of RS-422, but the protocol error (error code 6A) may be detected during the communication. (The operation will be continued even if this error code is displayed.)

(2) In case of MICRO-EH as slave station

Configure port2 of MICRO-EH as transmission procedure 2 with station number.

Set the parameter in special internal output WRF03D referring table 6.27.

WRF03D :	15	14	13	12	11	10	9	8	7	6	5	4	3	2	1	0
	a	b	c	0	d				e							
Initial value	0	0	0	0	0	0	0	0	0	0	0	0	0	0	0	0

Figure 6.70 Special internal output of port2 configuration

Table 6.28 Configuration of EH-CPU communication port

area	value	contents	remark
a	0	Indicate after setting	After setting, system set zero.
	1	Request change of setting	When requesting change of setting, one is set
b	0	Transmission procedure 1	
	1	Transmission procedure 2	
c	0	Without station number	
	1	With station number	
d	0	Transmission speed	4800 bps
	1		9600 bps
	2		19.2 kbps
	3		38.4 kbps
	Except above		4800 bps
e	0 to 31	Station number*	To specify using BCD

« Note »

- ◆ MICRO-EH without port 2 (10 points and 14 points) can't be used as slave station.
- ◆ Implement wiring according to RS-422 interface.

6.6.6 Error detection in simple data link mode

As described before, data link is operated by using Hi-Protocol communication. EH-SIO detects errors from slave stations. In case sending request has an error, error code will be stored in WRF000 in each slave station (self diagnostic error code). Refer to the instruction manual for detailed information of the error code.

In this section, error information detected by EH-SIO is described.

■ Error in initial setting

Detail error information can be confirmed by referring the execution result of TRNS 9 command of t parameter, return code of s parameter and data receiving area. In case of error bit (t+2) is turned ON after execution of TRNS 9 command, there is some detected error.

Table 6.29 Simple data link mode initial setting error table

No.	Error Code	Name	Error level	Detail contents
1	HFF	CPU error	---	EH-SIO operation has been stopped due to the error detection of EH-CPU (L.RES ON) was done.
2	---	Watch dog timer error	Fatal Failure	MPU of EH-SIO can't operate according the system program anymore, EH-SIO has detected watch dog timer error of MPU.
3	H03	OS system error	Fatal Failure	EH-SIO has detected an error of system OS.
4	H50	Invalid command specifying error	Warning	TRNS 9 command has been executed at the port specified as slave function or simple data link function.
5	H51	Over flow error of number of specified functions	Warning	There is no EH-SIO mounting, over flow of number of specified functions such as slave function or simple data link function.
6	H81	Non-supported command error	Warning	-Non-supported command by EH-SIO has been specified. -Multiple initial settings have been done with same port even if the first initial setting has been done. (more than twice execution of initial setting)
7	H82	Initial setting error	Warning	-The parameter of initial setting of EH-SIO was illegal. -The other command has been executed for a port except initial command before the completion of initial setting.

■ Error in simple data link mode

The detected error in data link operation is separated into two categories, the one is error of EH-SIO and the other is illegal response from slave station. In case of serious error, data link operation will be stopped. In case of communication error with slave station, the operation will be continued. The error cause will be indicated in high byte of status register WXus3. The indicated error code in WXus3 will be cleared by receiving normal response against the next sending request task code. If error is detected, entry flag of the slave will be off. EH-SIO will send a command to all registered slaves. So if a slave replies properly in the next cycle, the slave will come back to the link network.

Table 6.30 Simple data link mode error

No.	Error code	Name	Error level	Detail contents
1	HFF	CPU error	---	EH-SIO operation has been stopped due to the error detection of EH-CPU (L.RES ON) was done.
2	---	Watch dog timer Error	Fatal Failure	MPU of EH-SIO can't operate according the system program anymore, EH-SIO has detected watch dog timer error of MPU.
3	H03	OS system error	Fatal Failure	EH-SIO has detected an error of system OS.
4	H50	Non-valid command error	Warning	TRNS 9 command has been used for the port specified as SLAVE function or simple data link function.
5	H8A	Parity error	Warning	Parity error has been detected in the received data by EH-SIO.
6	H8B	Framing error	Warning	Framing error has been detected in the received data by EH-SIO.
7	H8C	Over run error	Warning	Over run error has been detected in the received data by EH-SIO.
8	H8D	Check code error	Warning	Check code error has been detected in the received data by EH-SIO.
9	H8E	Receiving timeout error	Warning	EH-SIO could not complete the receive operation within the specified time.
10	H8F	Sending timeout error	Warning	EH-SIO could not complete the send operation within the specified time. (the monitoring time interval is fixed and it is not possible to change this time interval.)
11	H91	Receiving Illegal message Contents data	Warning	EH-SIO receives message data including illegal data.

« Note »

EH-SIO is checking parity error and framing error in every byte. In case of Hi-Protocol mode, since only the newest error is indicated, "parity error" and "framing error" can be overwritten by newest error such as "check code error". So, if the "check code error" is detected, check also transmit character structure and transmit speed.

Chapter 7 System setup

7.1 Trial Run

■ Check item

Please check the item of Table 7.1.

Table 7.1 Check item at the time of a trial run

No.	Item	Contents
1	Modules except EH-SIO	<ul style="list-style-type: none"> • Is wiring of a power supply etc. right? • Do the type & version of EH-CPU correspond to EH-SIO? • Is the ladder program download to EH-CPU?
2	Module mounting	<ul style="list-style-type: none"> • Is mechanical connection good? • Is the attachment position of EH-SIO on the basic base or the expansion base?
3	Set up of communication setting switch	<ul style="list-style-type: none"> • Is it correct operation mode? (Transmission speed, Transmission code configuration, Communication I/F of port2)
4	Connection with external device	<ul style="list-style-type: none"> • Is a communication cable correct connection? • Is mechanical connection good?

■ The procedure of trial run

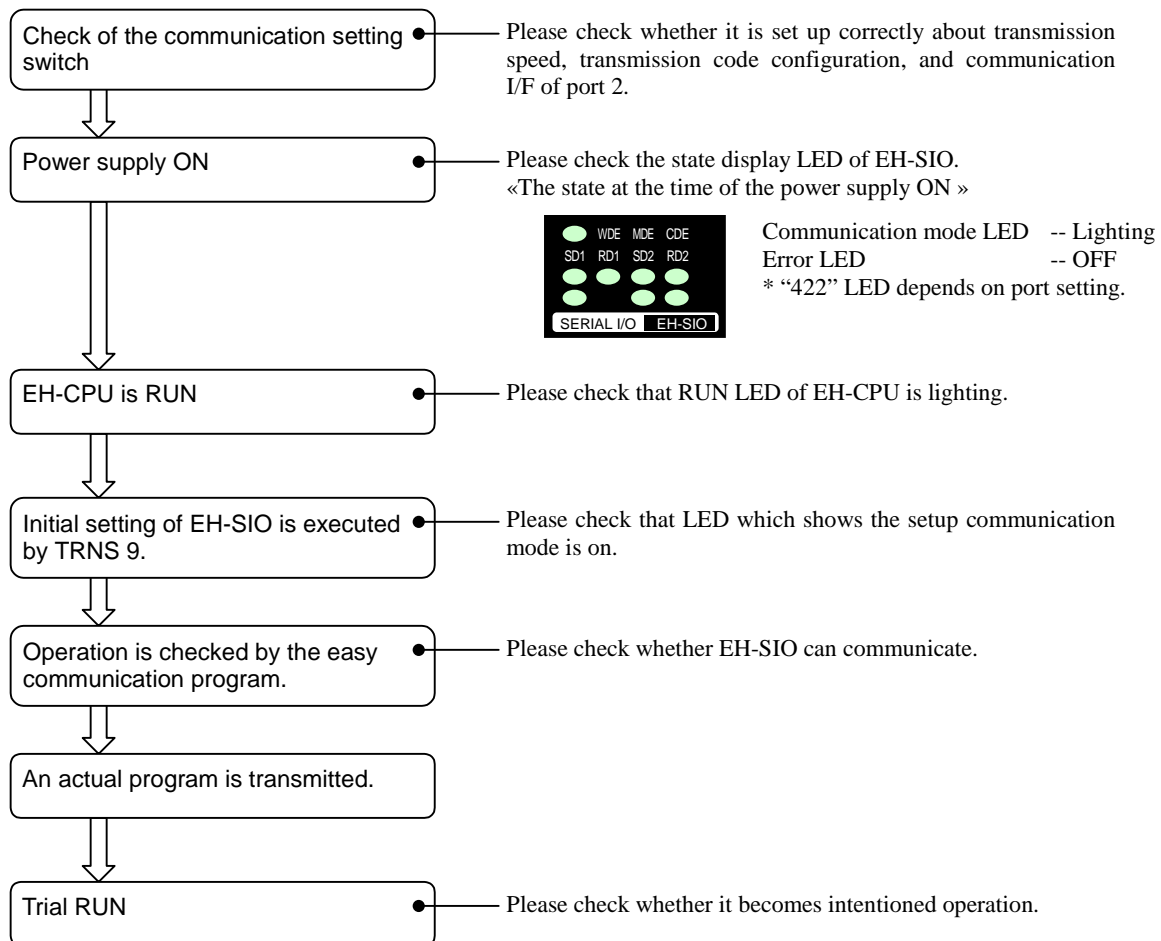

Figure 7.1 Flow of the trial RUN

7.2 Error indication

There are three error display indication in EH-SIO. The meaning and factor of each error indication are explained as below.

(1) LED indication

Three kinds of LED showing "error" exist in the state display LED. The error of EH-SIO can be checked visually.

Table 7.2 Error LED indication

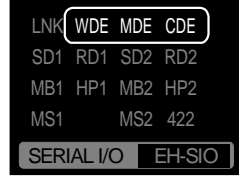
State display LED	Contents of abnormalities	
	WDE	RED lighting when microprocessor error (watch dog timer error) occurs. EH-SIO stops operation. In this state, the data from external device or the command from EH-CPU is not received.
	MDE	RED lighting when hardware error (module error) occurs. EH-SIO stops operation. In this state, the data from external device or the command from EH-CPU is not received.
	CDE	RED lighting when communication error or command error occurs. EH-SIO continues operation. And off after error factor removed.

(2) Status register

There are four bits showing "errors" in a status register. Errors can be checked by the ladder program, the monitor by peripheral unit, etc.

		WXrus0/1															
Bit		15/31	14/30	13/29	12/28	11/27	10/26	9/25	8/24	7/23	6/22	5/21	4/20	3/19	2/18	1/17	0/16
Name		XCNT	XHS	XIC	---	---	XMDE	XCDE	XDTE	CD	CS	DR	IFS	TII	PTE	OBE	IBE
A/B	A : For Port 1 B : For Port 2						↑	↑	↑						↑		

Figure 7.2 Status Register

Table 7.3 Status register abnormal display flag

Abnormal bit	Contents of abnormal
XMDE	Activated when hardware error occurs. EH-SIO stops operation.
XCDE	Activated when command error occurs. Inactivated after error factor removed.
XDTE	Activated when wrong data received. Inactivated when new command received form EH-CPU or PTE bit ON.
PTE	Activated when communication port error occurs. Inactivated when new command received form EH-CPU or XDET bit ON.

« Note »

XDTE is turned on when error are detected from the sent data or received data. Moreover, if the error which PTE turns on occur or EH-SIO receives a new command, it turns off. If two or more errors occur continuously, the XDTE flag may turn off. Therefore, in case you create a program which refers to this flag, be careful.

The same is said of PTE.

(3) Return code of TRNS 9 command

When TRNS 9 command is executed, an execution result is stored at the top word of s parameter as follows.

Table 7.4 Abnormal factor and display

No	Return code	Name	Error level	Status Register				Status display LED		
				XMDE	XCDE	XDTE	PTE	WDE	MDE	CDE
1	(None)	Watch dog timer error	Serious failure	--	--	--	--	○	◎	◎
2	HFFxx	EH-CPU error	Serious failure	ON	--	--	--	●	○	●
3	H01xx	ROM error	Serious failure	ON	--	--	--	●	○	●
4	H02xx	RAM error	Serious failure	ON	--	--	--	●	○	●
5	H03xx	OS system error	Serious failure	ON	--	--	--	●	○	●
6	H21xx	Range check error	Warning	OFF	OFF	OFF	OFF	●	●	●
7	H22xx	Sending data area setting error	Warning	OFF	OFF	OFF	OFF	●	●	●
8	H23xx	Sending data area range error	Warning	OFF	OFF	OFF	OFF	●	●	●
9	H24xx	Receiving data area setting error	Warning	OFF	OFF	OFF	OFF	●	●	●
10	H25xx	Receiving data area range error	Warning	OFF	OFF	OFF	OFF	●	●	●
11	H28xx	Area overlap error	Warning	OFF	OFF	OFF	OFF	●	●	●
12	H30xx	Command timeout error	Warning	OFF	OFF	OFF	OFF	●	●	●
13	H40xx	Receiving data overflow	Warning	OFF	OFF	OFF	OFF	●	●	●
14	H50xx	Designated Invalid command	Warning	OFF	OFF	OFF	OFF	●	●	●
15	H51xz	Number of entry over	Warning	OFF	OFF	OFF	OFF	●	●	●
16	H81xx	Command not-supported	Warning	OFF	ON	OFF	OFF	●	●	○
17	H82xx	Initial setting error	Warning	OFF	ON	OFF	OFF	●	●	○
18	H83xx	Transmission data error	Warning	OFF	ON	OFF	OFF	●	●	○
19	H84xx	Receive buffer full	Warning	OFF	OFF	OFF	ON	●	●	○
20	H85xx	Connect error	Warning	OFF	OFF	OFF	ON	●	●	○
21	H8Axx	Parity error	Warning	OFF	OFF	OFF	ON	●	●	○
22	H8Bxx	Framing error	Warning	OFF	OFF	OFF	ON	●	●	○
23	H8Cxx	Overrun error	Warning	OFF	OFF	OFF	ON	●	●	○
24	H8Dxx	Check code error	Warning	OFF	OFF	ON	OFF	●	●	○
25	H8Exx	Timeout error (Receive)	Warning	OFF	OFF	OFF	ON	●	●	○
26	H8Fxx	Timeout error (Send)	Warning	OFF	OFF	OFF	ON	●	●	○
27	H90xx	Error message reception	Warning	OFF	OFF	ON	OFF	●	●	○
28	H91xx	Message data injustice	Warning	OFF	OFF	ON	OFF	●	●	○
29	H92xx	Designated query error (Modbus mode)	Warning	OFF	ON	OFF	OFF	●	●	○

Indication of status register -- : A former state is held.

Indication of status display LED ○ : Lighting ● : OFF ◎ : A former state is held.

7.3 Troubleshooting

■ Main check flow

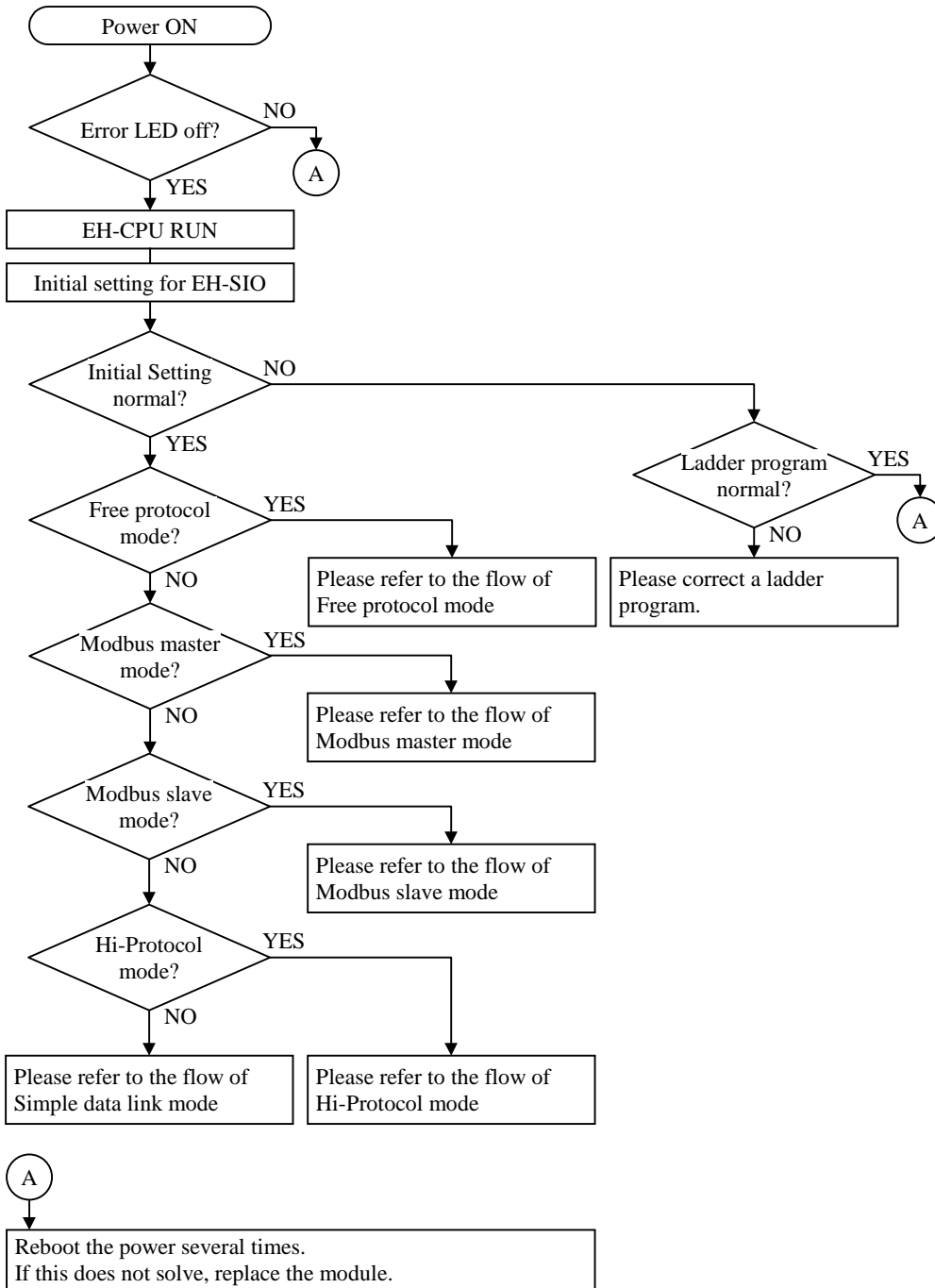

📖 Reference :

- EH-SIO does not start communication, unless initial setting is completed. Initial setting completion of the communication port can be checked with the "XIC flag" of the status register.
For port 1 ... Xus13 (u : Unit No. , s : Slot No.)
For port 2 ... Xus29 (u : Unit No. , s : Slot No.)
- The self-check function is supported by EH-SIO of software Ver.2.1. Failure of hardware is detectable by using the self-check function. Please refer to "8.3 Self-check mode" for further information.

■ Check flow of Free protocol mode

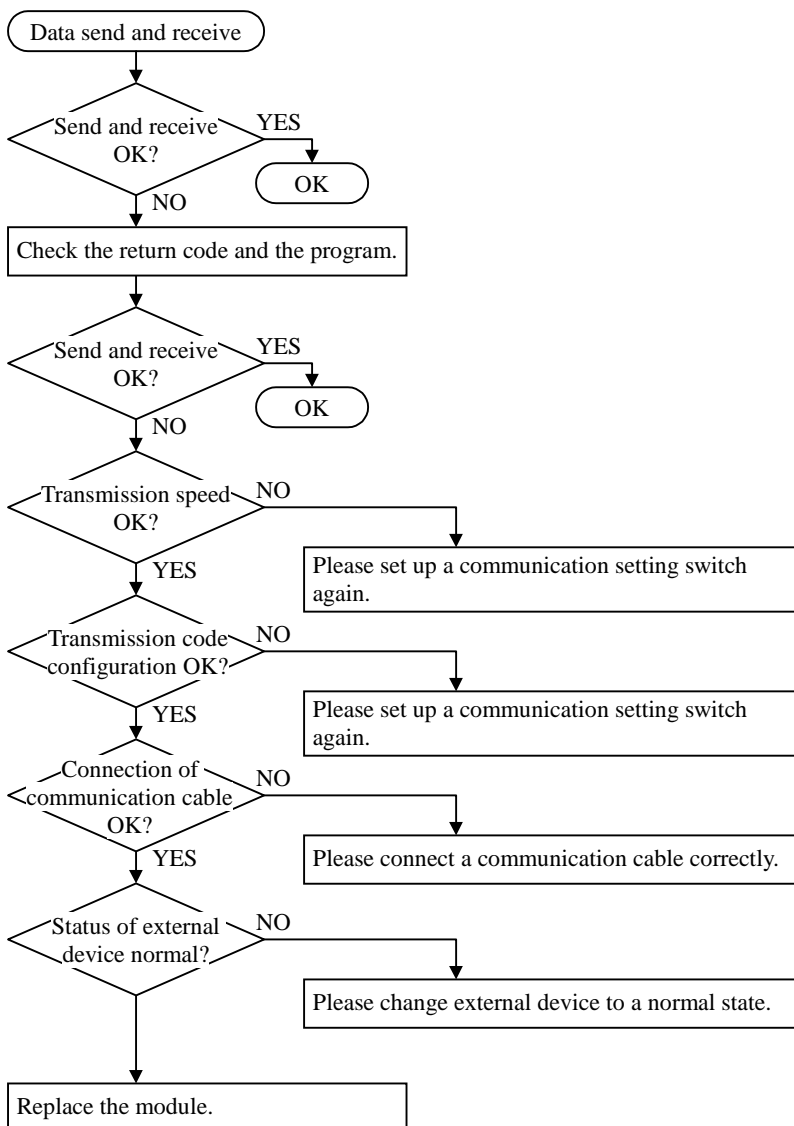

Reference :

- If a call-back function (the function to return the transmitted data as it is) is in external device, communication can be tested only by the set of EH-150 and external device.
- When the transmission speed of EH-SIO is set up very low compared with the transmission speed of external apparatus, it is impossible to detect data reception. In this case, an error does not occur.

■ Check flow of Modbus master mode

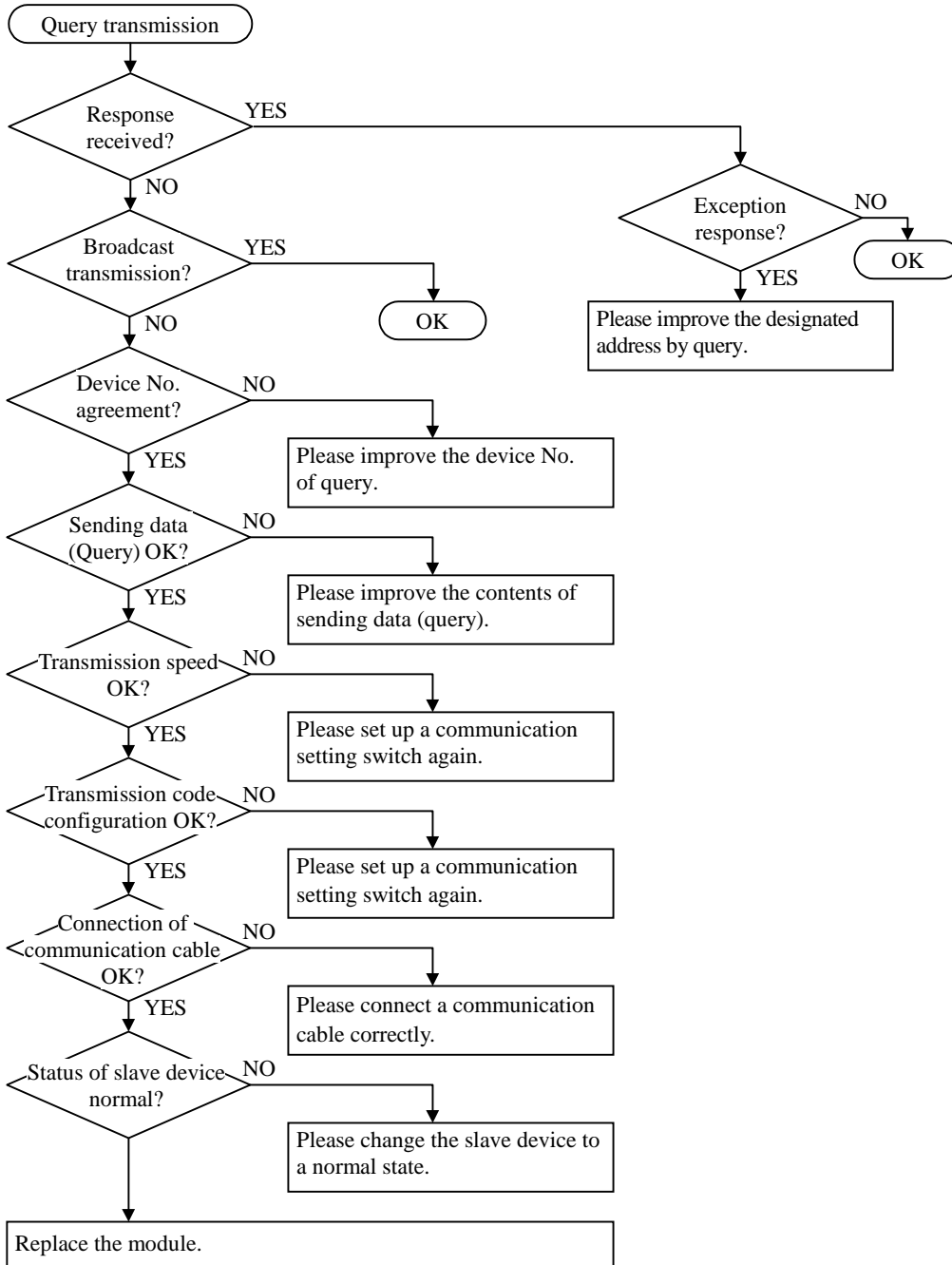

Reference :

In case of the Modbus transmission code RTU, H80 - HFF are contained in data. If 7 bit transmission code configuration is used, CRC error will be detected, and a response will not return from slave device. Be sure to use 8 bit transmission code configuration.

■ Check flow of Modbus slave mode

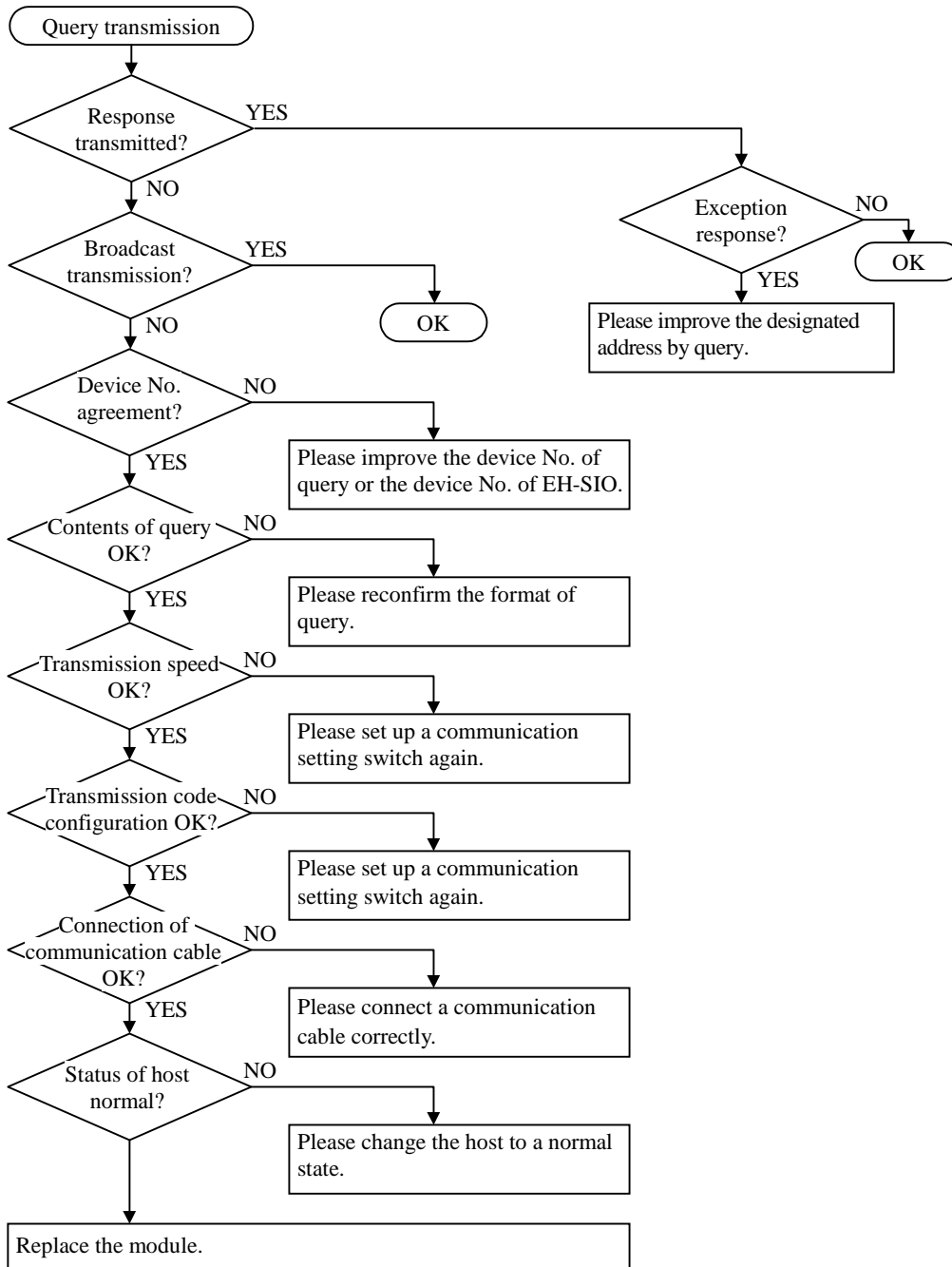

📖 Reference :

- In case of the Modbus transmission code RTU, H80-HFF are contained in data. If 7-bit transmission code configuration is used, CRC error will be detected, and a response will not return from slave device. Be sure to use 8-bit transmission code configuration.
- Master might fail to receive data from slaves if response time is too short. Response time of EH-SIO is adjustable. Please change this parameter if necessary.

■ Check flow of Hi-Protocol mode

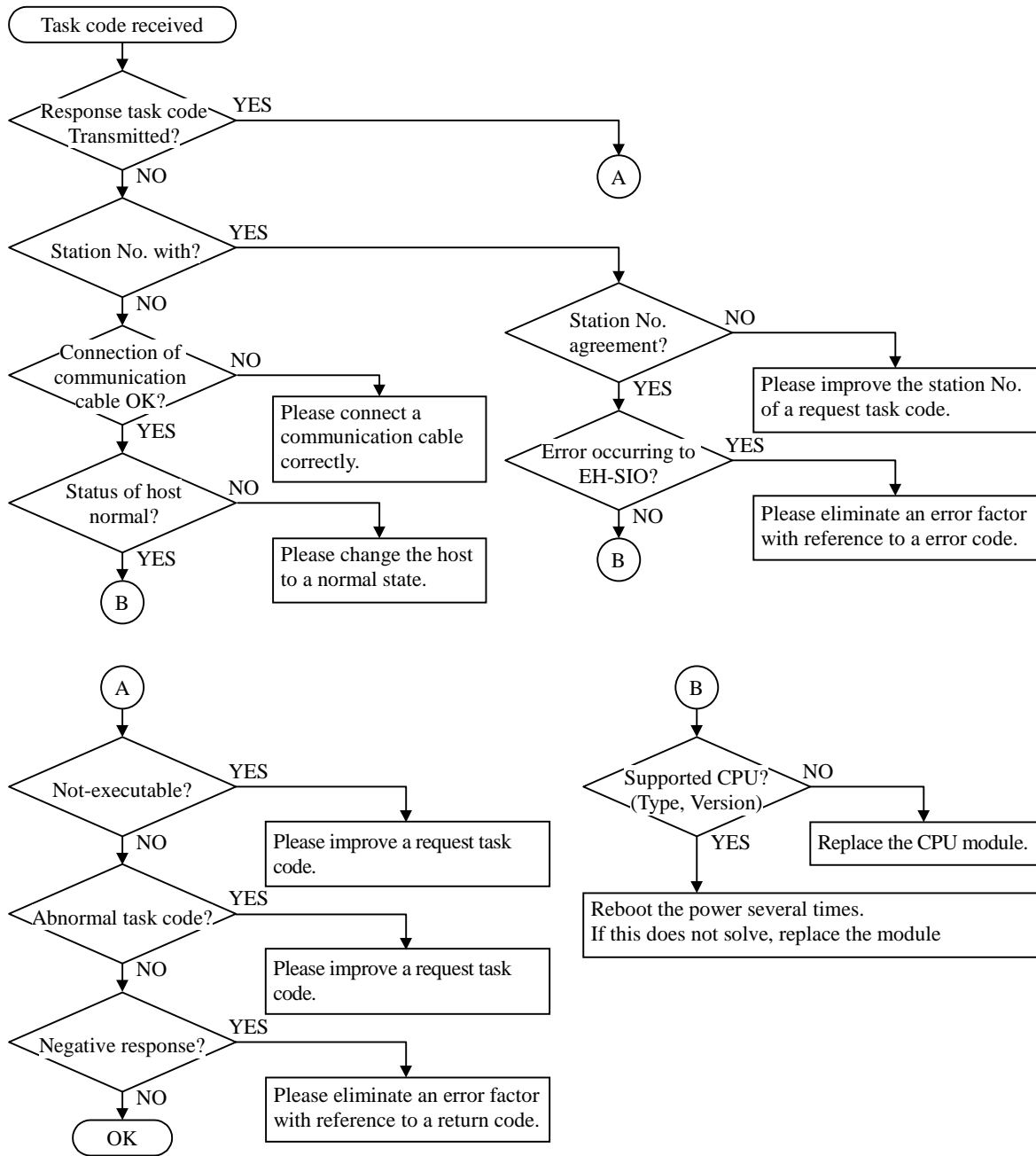

📖 Reference :

- The cause which cannot communicate has many wiring mistakes of a communication cable. When communication does not work, please check connection of a cable first.
- EH-SIO of software ver. 2.0 does not support transmission control procedure 2. If it's configured as procedure 2, it work with procedure 1. (EH-SIO of software ver. 1.0 is not supported Hi-Protocol mode.)
- Although EH-SIO can change transmission configuration, the transmission configuration of Hi-Protocol is 7bit / even parity / 1 stop. Please set the transmission configuration of EH-SIO as 7bit / even parity / 1 stop.
- In the case of a task code with station No., EH-SIO does not return a negative response, even if a parity error or framing error occurs in the request task code.

■ Check flow of Simple data link mode

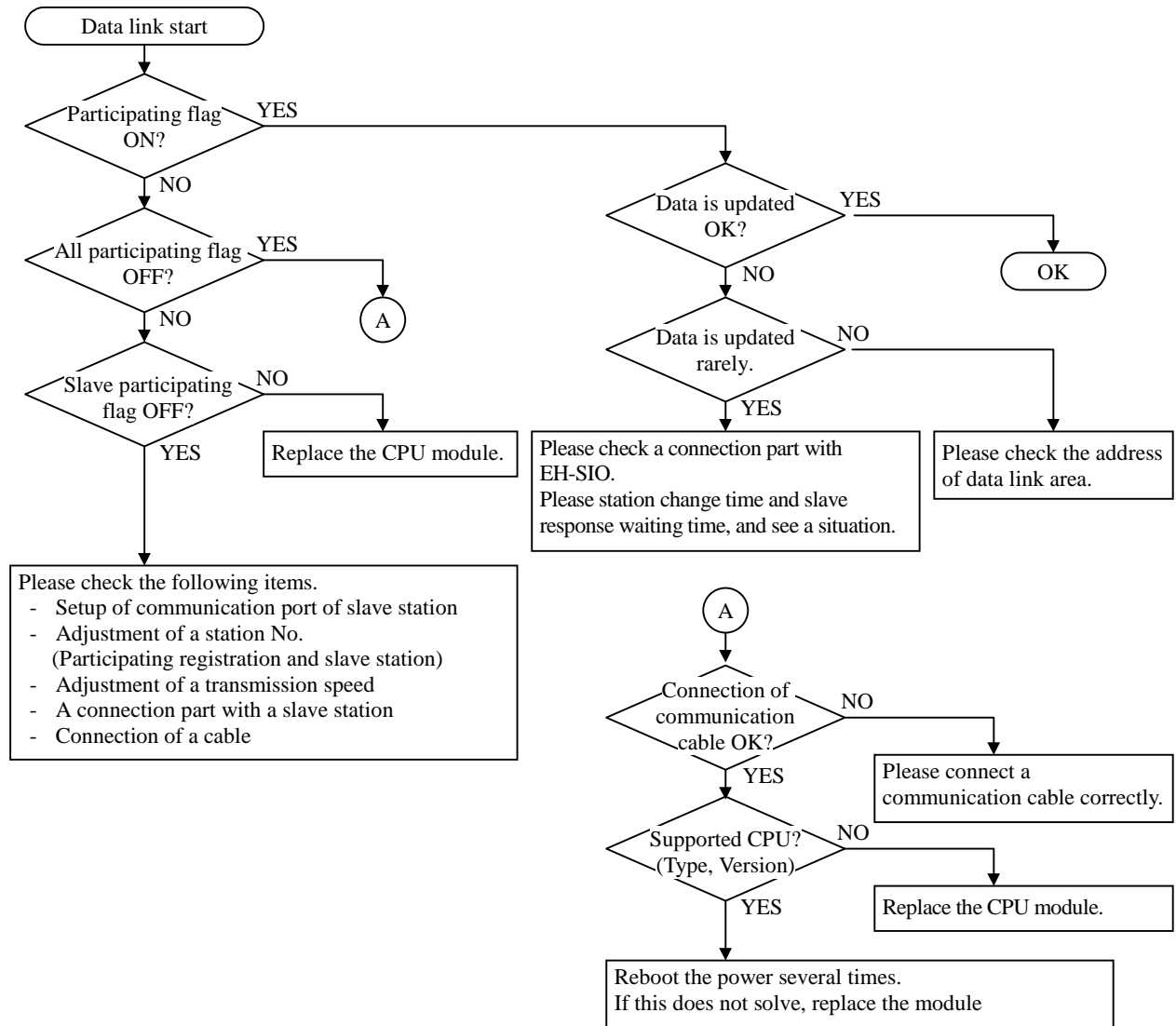

📖 Reference :

- The cause which cannot communicate has many wiring mistakes of a communication cable. When communication does not work, please check connection of a cable first.
- A setup of the transmission configuration of EH-SIO should surely use 7 bits / even parity / 1 stop bit.
- The capacity of an internal output changes with models of CPU. Moreover, the classification of an internal output may not exist. (There is no area of WL in MICRO-EH.)

Please check the internal output of a slave station and assign link area.

■ Combination with a CPU module

(1) Combination with EH-CPU which is not supporting EH-SIO

CPU modules other than EH-CPU516 / 548 are not supporting the TRNS 9 command. If TRNS 9 command is executed by these CPU modules, an execution bit becomes being ON, and a normal completion flag / error flag does not turn on. In addition, an error code is not stored in the return code area of TRNS 9.

(2) EH-SIO Software Ver. 1.0

Function of EH-SIO	CPU module		
	EH-CPU516 (Ver.E2.00 / E2.01) EH-CPU548 (Ver.E4.00 / E4.01)	EH-CPU516 (Ver.E2.02~E2.06) EH-CPU548 (Ver.E4.02~E4.05)	EH-CPU516 (Ver.E2.07 or newer) EH-CPU548 (Ver.E4.06 or newer)
Free-Protocol	NG (1)	OK	OK
Modbus Master (RTU)	NG (1)	OK	OK
Modbus Master (ASCII)	NG (2)	NG (2)	NG (2)
Modbus Slave (RTU)	NG (1)	OK	OK
Modbus Slave (ASCII)	NG (2)	NG (2)	NG (2)
Modbus Slave (I/O mapping)	NG (3)	NG (3)	NG (3)
Hi-Protocol (procedure 1)	NG (4)	NG (4)	NG (4)
Hi-Protocol (procedure 2)	NG (4)	NG (4)	NG (4)
Simple data link	NG (2)	NG (2)	NG (2)

(3) EH-SIO Software Ver. 2.0

Function of EH-SIO	CPU module		
	EH-CPU516 (Ver.E2.00 / E2.01) EH-CPU548 (Ver.E4.00 / E4.01)	EH-CPU516 (Ver.E2.02~E2.06) EH-CPU548 (Ver.E4.02~E4.05)	EH-CPU516 (Ver.E2.07 or newer) EH-CPU548 (Ver.E4.06 or newer)
Free-Protocol	NG (1)	OK	OK
Modbus Master (RTU)	NG (1)	OK	OK
Modbus Master (ASCII)	NG (1)	OK	OK
Modbus Slave (RTU)	NG (1)	OK	OK
Modbus Slave (ASCII)	NG (1)	OK	OK
Modbus Slave (I/O mapping)	NG (1)	OK	OK
Hi-Protocol (procedure 1)	NG (5)	NG (5)	OK
Hi-Protocol (procedure 2)	NG (4)	NG (4)	NG (6)
Simple data link	NG (7)	NG (7)	OK

(4) EH-SIO Software Ver. 2.1

Function of EH-SIO	CPU module		
	EH-CPU516 (Ver.E2.00 / E2.01) EH-CPU548 (Ver.E4.00 / E4.01)	EH-CPU516 (Ver.E2.02~E2.06) EH-CPU548 (Ver.E4.02~E4.05)	EH-CPU516 (Ver.E2.07 or newer) EH-CPU548 (Ver.E4.06 or newer)
Free-Protocol	NG (1)	OK	OK
Modbus Master (RTU)	NG (1)	OK	OK
Modbus Master (ASCII)	NG (1)	OK	OK
Modbus Slave (RTU)	NG (1)	OK	OK
Modbus Slave (ASCII)	NG (1)	OK	OK
Modbus Slave (I/O mapping)	NG (1)	OK	OK
Hi-Protocol (procedure 1)	NG (5)	NG (5)	OK
Hi-Protocol (procedure 2)	NG (4)	NG (4)	OK
Simple data link	NG (7)	NG (7)	OK

NG(1) Initial setting works. Odd bytes of transmission and reception are not performed properly.

NG(2) Communication port becomes an initial-setting error (command not supported error).

NG(3) Operates in the state without I/O mapping.

NG(4) Initial setting works. Communication port is no response to a request.

NG(5) Initial setting works. EOT is returned to ENQ after request task code reception. (Response data is not returned.)

NG(6) Communicates by transmission control procedures 1.

NG(7) Initial setting works. Link operation does not start.

■ The solution for each error code

Table 7.5 The solution for each error code

No	Return code	Name	Solution
1	(None)	Watch dog timer error	Please eliminate the source of a noise, reboot on a power supply, and see a situation.
2	HFFxx	EH-CPU error	
3	H01xx	ROM error	
4	H02xx	RAM error	
5	H03xx	OS system error	
6	H21xx	Range check error	Please check s parameter.
7	H22xx	Sending data area setting error	Please check s parameter. (designation of sending data area)
8	H23xx	Sending data area range error	
9	H24xx	Receiving data area setting error	Please check s parameter. (designation of receiving data area)
10	H25xx	Receiving data area range error	
11	H28xx	Area overlap error	Please check whether there is any overlap in s parameter, t parameter, sending data area, and receiving data area.
12	H30xx	Command time-out error	Please enlarge time of the command timeout of s parameter.
13	H40xx	Receiving data overflow	Please enlarge send data area size of s parameter.
14	H50xx	Designated Invalid command	Please check the command of s parameter.
15	H51xz	Number of entry over	Please make into less than 8 sets the number of EH-SIO currently operated in Modbus slave mode, Hi-Protocol mode, Simple data link mode. * When at least less than eight sets of this error come out, please once turn off a power supply.
16	H81xx	Command not-supported	Please check the command of s parameter.
17	H82xx	Initial setting error	Please check whether initial setting of a port has ended.
18	H83xx	Transmission data error	Please check whether it is satisfactory to the value stored in sending data area.
19	H84xx	Receive buffer full	Please execute the read command and read the data of a receiving buffer.
20	H85xx	Connect error	Please check the state of the control signal of external apparatus and connection of a connection cable.
21	H8Axx	Parity error	Please check a setup of DIP Sw.
22	H8Bxx	Framing error	
23	H8Cxx	Overrun error	
24	H8Dxx	Check code error	Please check the pattern of a check code and message code configuration.
25	H8Exx	Timeout error (Receive)	Please enlarge receiving timeout time designated by initial setting.
26	H8Fxx	Timeout error (Send)	Please check the state of the control signal of external apparatus and connection of a connection cable.
27	H90xx	Error message reception	The exception response returned from Modbus slave device. Please check the parameter and data of send data area which are send as query.
28	H91xx	Message data error	Please check the send data of send data area. Moreover, please check the character (Binary, ASCII) of the data sent from external device.
29	H92xx	Designated query error (Modbus mode)	Please check the parameter (the number of data to read and the number of send data bytes) of send data area which send as query.

« Note »

Priority of parity error , framing error and overrun is as follows.

Parity error > Framing error > Overrun error

Chapter 8 Daily and Periodic Inspection

In order to use the EH-SIO functions in the most desirable condition and maintain the system to operate normally, it is essential to conduct daily and periodic inspections.

8.1 Daily inspection

Verify the following items while the system is running.

Table 8.1 Items for daily inspection

ITEM	LED display	Normal status	Main cause of error
LED display of EH-SIO	WDE	OFF	Lighting : Watch dog timer error, etc.
	MDE	OFF	Lighting : Module error, etc.
	CDE*1	OFF	Lighting : Command error, etc.

*1: The light is on when data transmission between EH-SIO and external device or between EH-SIO and EH-CPU is not executed normally. However, the light will be off if next data transmission is executed normally.

ITEM	LED display	Normal status	
LED display of EH-SIO	LNK*2	Under simple data link mode operation	→ Lighting
	SD1	Port1 Data being transmitted	→ Blinking
	RD1	Port1 Data being received	→ Blinking
	MB1	Port1 Under Modbus master/slave mode operation	→ Lighting
	HP1*2	Port1 Under Hi-protocol mode operation	→ Lighting
	MS1	Port1 Under Modbus master mode operation	→ Lighting
	SD2	Port2 Data being transmitted	→ Blinking
	RD2	Port2 Data being received	→ Blinking
	MB2	Port2 Under Modbus master/slave mode operation	→ Lighting
	HP2*2	Port2 Under Hi-protocol mode operation	→ Lighting
	MS1	Port2 Under Modbus master mode operation	→ Lighting
	422	Port2 Used I/F --- RS-422/RS-485	→ Lighting
	Port2 Used I/F --- RS-232C	→ OFF	

*2 : Simple data link mode and Hi-Protocol mode correspond from software Ver.2.0.

8.2 Periodic inspection

Turn off the power for the external I/O and check the following items once every six months.

Table 8.2 Items for periodic inspection

Part	Item	Check criteria	Remarks
Programming device to CPU	Check operation of programming device	All switches and display lamps work normally.	
Power supply	Check for voltage fluctuations	85 to 264 V AC (AC power supply) 21.6 to 26.4 V DC (DC power supply)	Tester
Installation and connecting areas	(1) All modules are securely fixed (2) All connectors fit snugly (3) All screws are tight (4) All cables are normal	No defects	Tighten Check insertion Tighten
Ambient environment	(1) Temperature (2) Humidity (3) Other	0 to 55 °C 20 to 90 % RH (no condensation) No dust, foreign matter, vibration	
Spare parts	Check number of parts, storage condition	No defects	
Program	Check program contents	Compare the contents of the latest program saved and CPU contents, and make sure they are the same	Check both master and backup.

8.3 Self-check mode

The hardware self-check function is supported by software ver.2.1.

When communication is not performed correctly, the self-check function analyzes whether it is failure of EH-SIO, or it is the problem of a cable or external devices.

« Note »

During self-check mode execution, communication with external devices and data sending / receiving with EH-CPU cannot be performed. Please be sure to carry out after stopping operation.

8.3.1 Check item

The item which can be checked by self-diagnostic mode is shown in the following table.

Table 8.3 Self-check Items

No.	Check item	Contents
1	ROM Check	It checks whether there are any errors in a system program.
2	RAM Check 1	It checks whether the memory which a system uses can be written or read properly.
3	RAM Check 2	It checks whether the memory which a system uses can be written or read properly.
4	LSI Check	It checks whether LSI of a system operates properly.
5	Port1 Loop back check	The loop back is carried out and the signal line of the communication port 1 is checked.
6	Port2 (RS-232C) Loop back check	The loop back is carried out and the signal line of the communication port 2 (RS-232C) is checked.
7	Port2 (RS-422/485) Loop back check	The loop back is carried out and the signal line of the communication port 2 (RS-422/485) is checked.
8	LED Check	Turn on or turn off of LED are checked.

8.3.2 Preparation before self-check

The loop back connector for port 1(RS-232C), port 2(RS-232C, RS-422 / 485) are required to perform self-check mode. Wiring of a loop back connector is shown in the following figure.

(1) For RS-232C port (Port1, Port2)

EH-SIO side

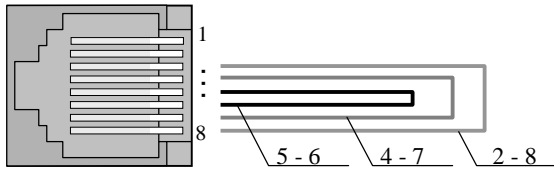

(2) For RS-422 / 485 port (Port2)

Attached connector

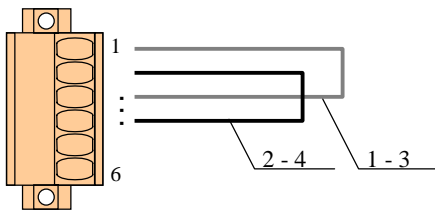

« Note »

Please prepare loop back connectors.

8.3.3 Starting of self-check mode

- (1) Operation of PLC is stopped, turn off the PLC power, and EH-SIO is removed.
- (2) Set the SW1-7,8 of Communication setting switch (DIPSW1) to on.
- (3) Plug in above 3 connectors to communication ports.
- (4) Turn on the PLC power.
- (5) Self-check will start. Please check LED status as shown Table 8.4

« Note »

In case of the product before software Ver.2.0, LED check mode will start. If a power supply is turned on, all LED except "WDE" LED will light up, and will turn off. Then, some LED blink.

⚠ The module consists of precise electronic products. When you set up this switch, please don't touch any parts around the communication setting switch.

8.3.4 Result of self-check

When self-check mode started, the item under checking is displayed on lower 2 line of the status display LED as Table 8.4.

When a check is completed, software version indication blinks every 1s.

When errors are detected, "WDE" LED turn on and corresponding LED remains lighting.

Table 8.4 LED display under self-check

No.	LED Display								Check item
	MB1	HP1	MB2	HP2	MS1	" "	MS2	422	
1	●								ROM Check
2		●							RAM Check 1
3			●						RAM Check 2
4				●					LSI Check
5					●				Port1 Check
6						●			Port2 (RS-232C) Check
7							●		Port2 (RS-422/485) Check
8	○	○	○	○	○	○	○	○	LED Check
9	○	○	○	○	○	○	○	○	Software version display

● : Turn ON ○ : Conditional turn ON " " is the LED part which is not printed at all.

■ LED Check

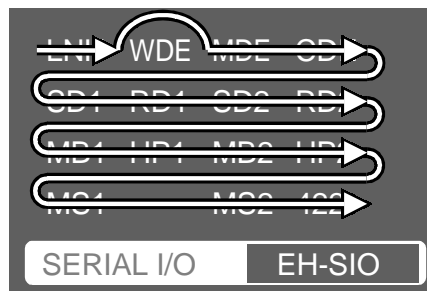

Figure. 8.1 Turn of the LED check

« Note »

Please check turn on / off of LED by users. In addition, "WDE" LED is not turned on at the LED check.

■ Software version display

If a check is completed, software version indication blinks every 1s. A software version is displayed as shown in the following figure.



Figure. 8.2 Version display LED

Ex.) In case of Ver.2.1, "MB2" and "422" blink.

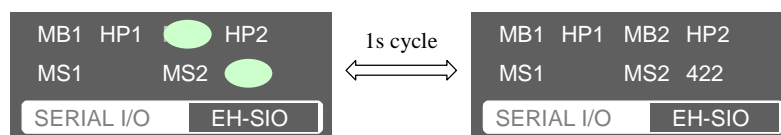

Appendix

A.1 ASCII code list

Table A.1 ASCII code list

				b8	b7	b6	b5											
								b8	0	0	0	0	0	0	0	0	0	0
								b7	0	0	0	0	0	1	1	1	1	
								b6	0	0	1	1	0	0	1	1		
								b5	0	1	0	1	0	1	0	1		
b8	b7	b6	b5	b4	b3	b2	b1	low	col									
It displays on the upper right.	It displays on the upper right.	It displays on the upper right.	It displays on the upper right.	0	0	0	0	0	0	NUL	TC7(DLE)	(SP)	0	@	P	'	p	
				0	0	0	1	1	TC1(SOH)	DC1	!	1	A	Q	a	q		
				0	0	1	0	2	TC2(STX)	DC2	"	2	B	R	b	r		
				0	0	1	1	3	TC3(ETX)	DC3	#	3	C	S	c	s		
				0	1	0	0	4	TC4(EOT)	DC4	\$	4	D	T	d	t		
				0	1	0	1	5	TC5(ENQ)	TC8(NAK)	%	5	E	U	e	u		
				0	1	1	0	6	TC6(ACK)	TC9(SYN)	&	6	F	V	f	v		
				0	1	1	1	7	BEL	TC10(ETB)	'	7	G	W	g	w		
				1	0	0	0	8	FE0(BS)	CAN	(8	H	X	h	x		
				1	0	0	1	9	FE1(HT)	EM)	9	I	Y	i	y		
				1	0	1	0	10	FE2(LF)	SUB(EOT)	*	:	J	Z	j	z		
				1	0	1	1	11	FE3(VT)	ESC	+	;	K	[k	{		
				1	1	0	0	12	FE4(FF)	IS4(FS)	,	<	L	¥	l			
				1	1	0	1	13	FE5(CR)	IS3(GS)	-	=	M]	m	}		
				1	1	1	0	14	SO	IS2(RS)	.	>	N	^	n	~		
1	1	1	1	15	SI	IS1(US)	/	?	O	_	o	DEL						

A.2 Outline of Modbus protocol

The communication system of Modbus is a single master / multi slave system. Only the master can transmit a demand (query) to designated slave or the broadcasting query to the all slaves. The slave performs the function according to query and returns a response message. In case of broadcasting query, the slave performs the demand of query and does not return a response message. The slave returns a response message to query for own device address.

Message configuration of query consists of device address of slave, function code which designate contents of command, data, error check field. Message configuration of respons is consists of check filed of command, response data, error check field.

The message configuration of query and response message are shown in the following figure.

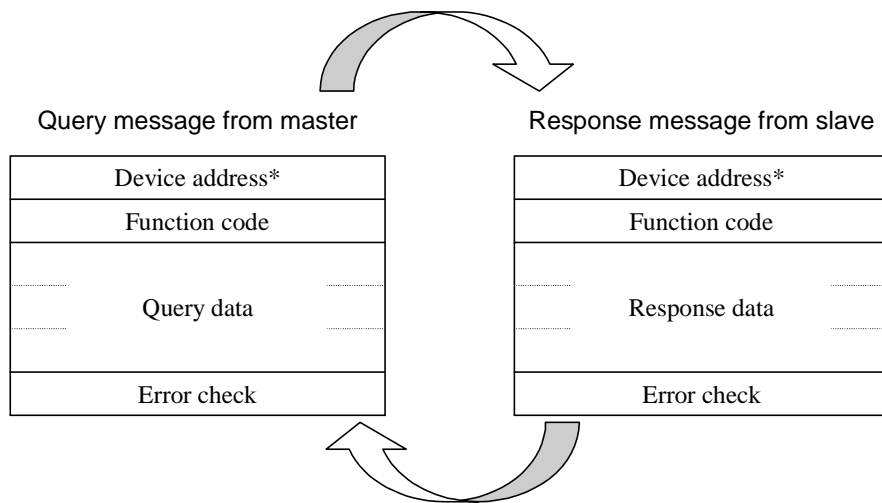

Figure A.1 The query - response cycle

There are two kinds of serial transmission modes, ASCII mode and RTU mode. However, either of modes can run on one network. In ASCII mode, 1 byte data is converted to ASCII code (two bytes) and transmitted. In RTU mode, 1 byte data is transmitted as it is.

The check algorithm of the error check field depends on transmission modes. In case of ASCII mode, the LRC (Longitudinal Redundancy Check) method is used. In case of RTU mode, the CRC (Cyclical Redundancy Check) method is used.

* Device address : In this book, it is written as "Device No.".

A.2.1 Modbus message configuration

Modbus message configuration changes with transmission modes.

(1) Message configuration of ASCII mode

In case of ASCII mode, a message starts in the ASCII character of ":"(0x3A), and finishes it as "CR / LF"(0x0D, 0x0A). The data allowed between start and end is "0"- "9" and "A"- "F."

Table A.2 Message configuration of Modbus ASCII mode

Start	Device Address	Function	Data	LRC Check	End
1 character “:”	2 characters	2 characters	n characters	2 character	2 character “CR / LF”

(2) Message configuration of RTU mode

In RTU mode, message starts with a silent interval of at least 3.5 character times (shown as T1–T2–T3–T4 in the figure below), and end with silent interval of at least 3.5 character times. The other fields are the 8-bit data.

Table A.3 Message configuration of Modbus RTU mode

Start	Device Address	Function	Data	CRC Check	End
T1-T2-T3-T4	8 bits	8 bits	n*8 bits	16 bits	T1-T2-T3-T4

A.2.2 Function code

The purposes of query from master to slave depends on function code in message frame as below.

Table A.4 The function code which EH-SIO is supporting

Function code	Function	
	Modbus Original	EH-SIO slave mode operation
01 (0x01)	Read Coil Status	Read continuous n points of bit output “Y”
02 (0x02)	Read Input Status	Read continuous n points of bit input “X”
03 (0x03)	Read Holding Registers	Read continuous n points of internal register “WR”
04 (0x04)	Read Input Registers	Read continuous n points of internal register “WM”
05 (0x05)	Force Single Coil	Write bit output “Y”
06 (0x06)	Preset Single Register	Write word internal output “WM”
15 (0x0F)	Force Multiple Coils	Write continuous n point of bit output “Y”
16 (0x10)	Preset Multiple Registers	Write continuous n points of internal register “WR”

The parameter assigned to a coil, input status, and various registers depend on the specification of devices. Please refer to the manual of each device for further information.

A.2.3 Error check

(1) LRC check

The error check field based on the Longitudinal Redundancy Check (LRC) is included in the message frame in ASCII mode. The target of LRC calculation is a portion (Device address, Function code, data) except the header (colon) and the terminator (CR/LF).

A procedure for generating LRC is:

1. Add all bytes in the message, excluding the starting 'colon' and ending CRLF. Add them into an 8-bit field, so that carries will be discarded.
2. Subtract the final field value from FF hex, to produce the ones-complement.
3. Add 1 to produce the two's-complement.

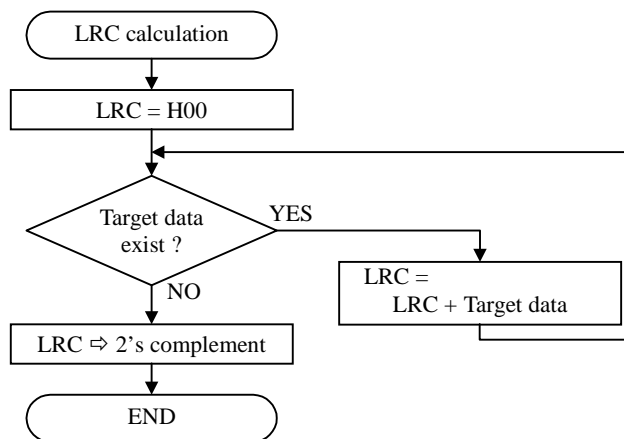

Figure A.2 Calculation procedure of LRC

Ex.) When coil information is read from the coil address 0000 (16 bits) of a slave (Device No. 08)

Query			
Field Name	(HEX)		
Device No.	08	0000	1000
Function code	01	0000	0001
Top address of coil (High)	00	0000	0000
Top address of coil (Low)	00	0000	0000
Number of coil (High)	00	0000	0000
Number of coil (Low)	10	+	0001 0000
			0001 1001

		2's complement calculated	1110 0110
			+ 1
			1110 0111

LRC	E7	←	E 7

(2) CRC check

The error check field based on the CRC system is included in the message frame in RTU mode. The target of CRC calculation is all messages (Device No., Function code, Data).

The CRC code is 16-bit data generated to the block of any data length of a 8-bit unit, which is calculated by generation polynomial of CRC-16($X^{16}+X^{15}+X^2+1$).

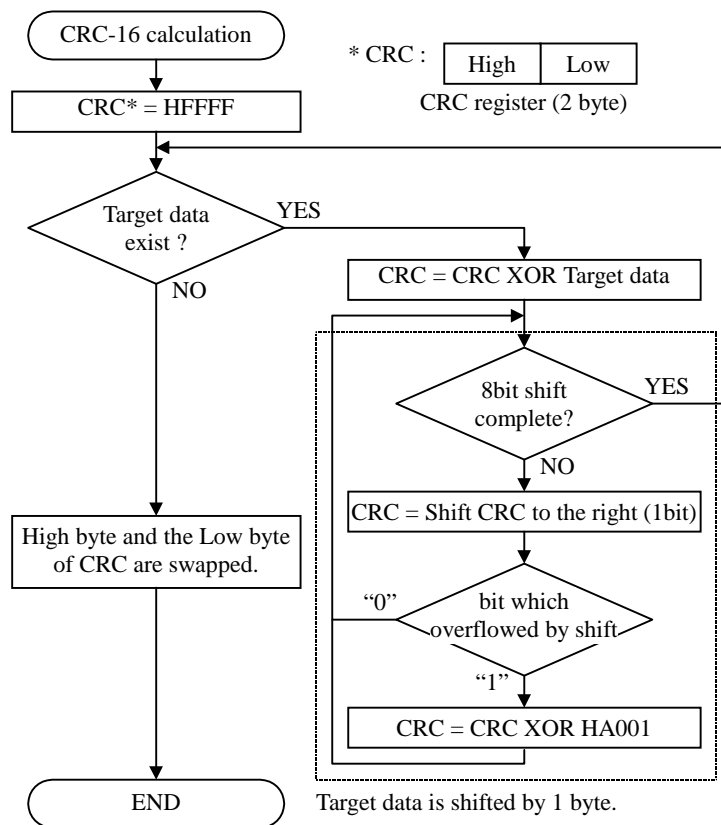

Figure A.3 Calculation procedure of CRC-16

Ex) The calculation method is explained using 2 bytes of data (0x0207) .

Procedure	CRC(Calculation middle)				Flag
CRC	1111	1111	1111	1111	
02			0000	0010	
XOR	1111	1111	1111	1101	
Shift right(1)	0111	1111	1111	1110	1
XOR 0xA001	1010	0000	0000	0001	
	1100	1111	1111	1110	
Shift right (2)	0110	1111	1111	1111	1
XOR 0xA001	1010	0000	0000	0001	
	1100	1111	1111	1110	
Shift right (3)	0110	0111	1111	1111	0
Shift right (4)	0011	0011	1111	1111	1
XOR 0xA001	1010	0000	0000	0001	
	1001	0011	1111	1110	
Shift right (5)	0100	1001	1111	1111	0
Shift right (6)	0010	0100	1111	1111	1
XOR 0xA001	1010	0000	0000	0001	
	1000	0100	1111	1110	
Shift right (7)	0100	0010	0111	1111	0
Shift right (8)	0010	0001	0011	1111	1
XOR 0xA001	1010	0000	0000	0001	
	1000	0001	0011	1110	

Procedure	CRC(Calculation middle)				Flag
	1000	0001	0011	1110	
07			0000	0111	
XOR	1000	0001	0011	1001	
Shift right (1)	0100	0000	1001	1100	1
XOR 0xA001	1010	0000	0000	0001	
	1110	0000	1001	1101	
Shift right (2)	0111	0000	0100	1110	1
XOR 0xA001	1010	0000	0000	0001	
	1101	0000	0100	1111	
Shift right (3)	0110	1000	0010	0111	1
XOR 0xA001	1010	0000	0000	0001	
	1100	1000	0010	0110	
Shift right (4)	0110	0100	0001	0011	0
Shift right (5)	0011	0010	0000	1001	1
XOR 0xA001	1010	0000	0000	0001	
	1001	0010	0000	1000	
Shift right (6)	0100	1001	0000	0100	0
Shift right (7)	0010	0100	1000	0010	0
Shift right (8)	0001	0010	0100	0001	
	1	2	4	1	
CRC	4	1	1	2	

A.2.4 Response message

When a slave receives a query except broadcasting, the slave must return a response. Operation of slave can be defined as following four patterns.

- 1) Query is received and processed properly.
- 2) Query is unreceived by communication error etc.
- 3) Although query was received, parity, CRC or LRC error was detected.
- 4) Although query was received, query cannot be processed by some reasons.

In case of 1), the slave returns the normal response according to the function code in the query.

In case of 2) 3), Since a slave cannot recognize query, it is no response. Therefore, it is necessary to make it a time-out error by host.

In case of 4), error response (exception response) is returned from a slave. An exception response consists of the device No., function code and data fields. The device No. of a slave is set to the device No. field like a normal response. The same function code as query is set to a function code, and the MSB is set to 1, by which a host can detect an exception response. The exception code which shows the exceptional contents is set to the data field.

An exception code and description are shown in the following table.

Table A.5 Exception code of Modbus protocol

Exception code	Name	Contents
01	Illegal function	The function code received in the query is not supported by the slave.
02	Illegal data address	The data address received in the query is not supported by the slave.
03	Illegal data value	A value contained in the query data field is not allowed for the slave.
04	Slave device failure	Impossible to respond due to device failure
05	Acknowledge	The slave has accepted the request and is processing it, but it takes time to response.
06	Slave device Busy	The slave is engaged in processing of the last command.

A.3 H series protocol (Hi-Protocol)

A.3.1 Outline

Hi-Protocol is special protocol between communication module of H/EH series and a host computer (here after host) or HMI. CPU module, COMM module, remote module, CPU link module, and Ethernet module, etc. of Hitachi H/EH series are able to handle Hi-protocol.

Task code (command code) and transmission control procedures are concretely specified in Hi-protocol. The outline of Hi-Protocol is shown in Figure. A.4.

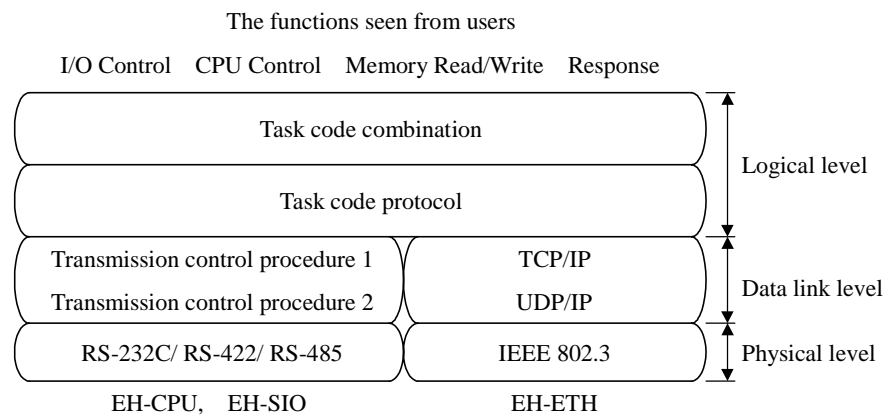

Figure.A.4 Outline of H/EH series communication protocol

In case of serial communication, physical level is RS-232C, RS-422 or RS-485. The procedure called one-sided startup is used on a data link level. This one-sided startup means that only a host can request to start communication.

In addition, although Hi-Protocol covers to access all CPUs over network, Hi-protocol on EH-SIO is limited that covers only CPU module mounted in the same base with the EH-SIO.

A.3.2 Hi-Protocol message configuration

The message format of Hi-Protocol is shown below.

■ Standard H protocol (Transmission control procedure 1)

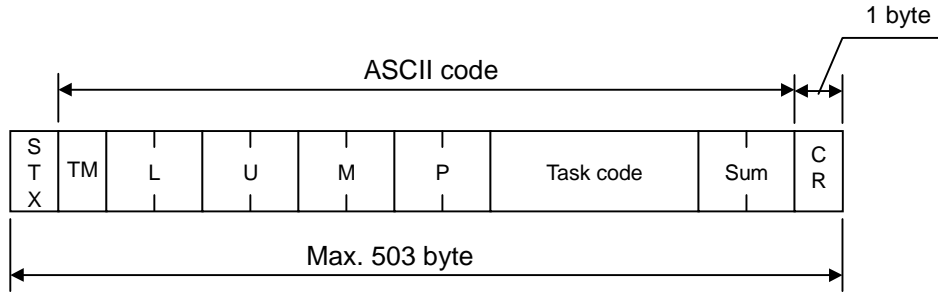

■ Simple H protocol (Transmission control procedure 2)

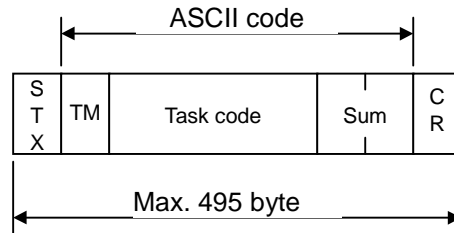

■ Standard H protocol with station No. (Transmission control procedure 1)

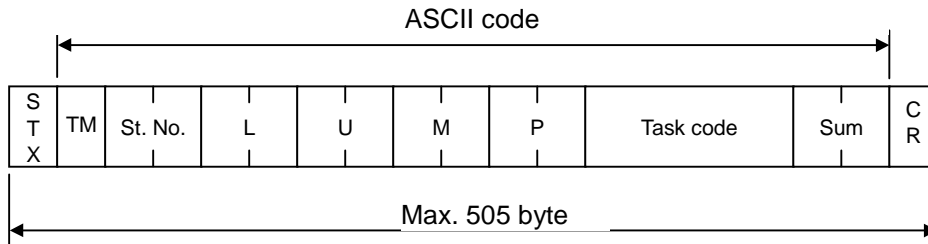

■ Simple H protocol with station No. (Transmission control procedure 2)

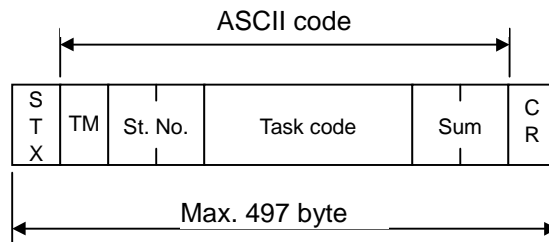

« Note »

- ◆ LUMP is a network address to identify CPU from a host. Since EH-SIO does not support to access remote CPU, LUMP should be always "FFFF0000."
- ◆ When communicating by transmission control procedures 2, a network address (LUMP) is not used.

Table.A.7 The parameter in a message

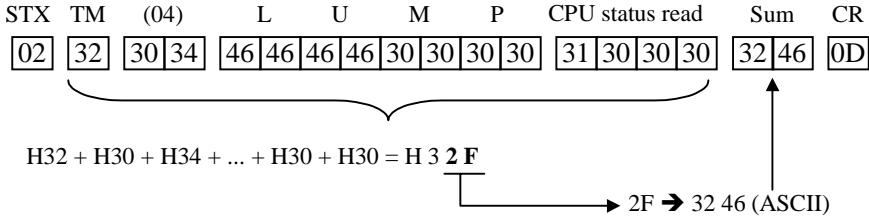
ITEM	CONTENTS
Response TM (Response timer)	When PLC receives a command from host, PLC will send back a response after waiting TM x 10ms. Possible range is 0-F, which corresponds with 0 - 150ms. In case of "with station No.", please set TM as 20ms or longer.
Station No.	The setting range is from 00 to 31 in BCD code.
LUMP Address	It is an address for access over CPU link network. L : Loop No. (When there are two LINK modules, smaller slot number is loop No.1.) U : Station No. of Link module M : Module No. (It is used for error detection etc. In case of address from CPU, it is always 00.) P : Port No. (It is used for error detection etc. In case of address from CPU, it is always 00.) * In case of EH-SIO, Please set as L:FF, U:FF, M:00, P:00. In case of transmission control procedure 2, LUMP address is not used.
Task code	Refer to following pages.
Sum	ASCII converted value of sum from TM to end of task code with 1 byte step. [Example] Station No. STX TM (04) L U M P CPU status read Sum CR 

A.3.3 Basic specification of transmission control procedure

The communication sequence of a host and PLC is shown in the following figure.

The minimum cycle

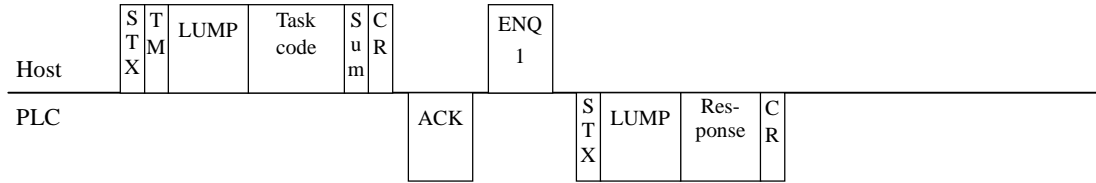

In case of CPU "Busy"

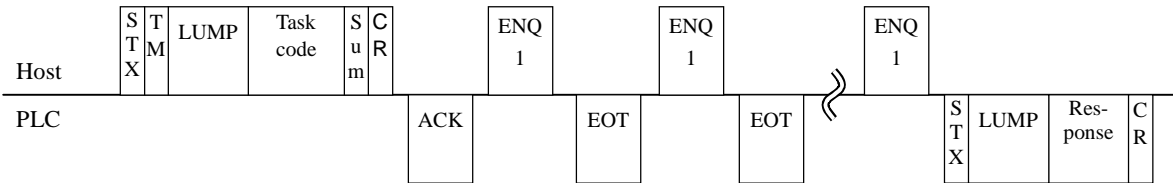
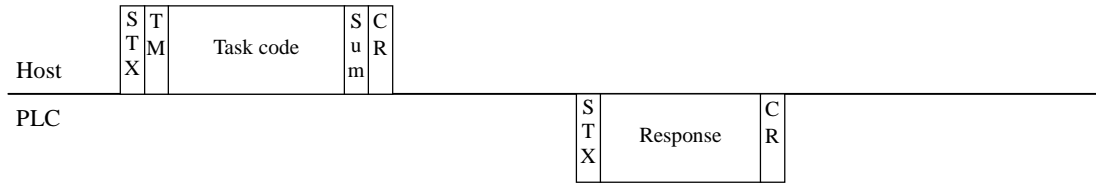

Figure.A.5 Transmission control procedure 1 Communication sequence diagram

The minimum cycle



In case of CPU "Busy"

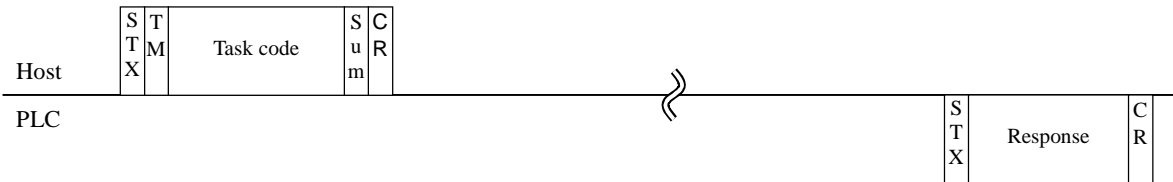

Figure.A.6 Transmission control procedure 2 Communication sequence diagram

If PLC cannot execute properly a request from a host, PLC returns a negative response NAK.

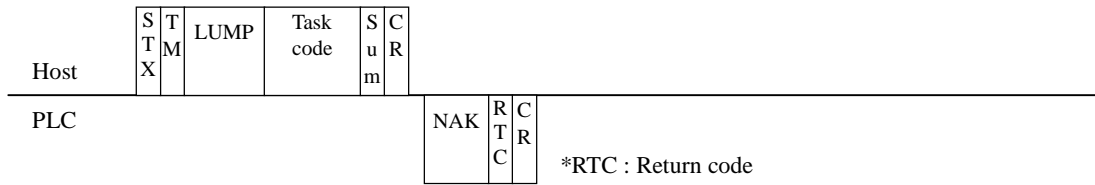

Figure.A.7 Transmission control procedure 1 Communication sequence diagram (Abnormal 1)

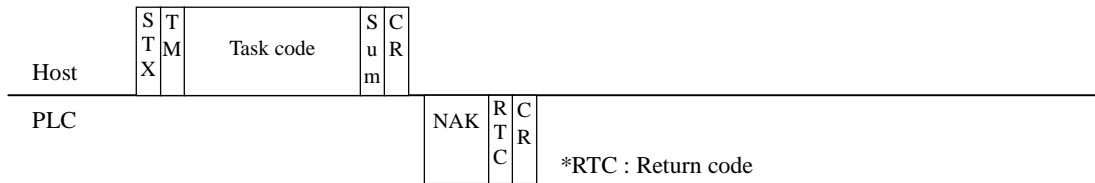

Figure.A.8 Transmission control procedure 2 Communication sequence diagram (Abnormal 1)

Table.A.8 Return code list

No.	RTC	Error factor	Priority
1	03	Framing error	High
2	01	Parity error	
3	04	Over-run error	
4	07	Receiving buffer error	
5	08	Receiving time-out error	
6	05	Protocol error	
7	06	ASCII error	
8	02	Sum error	Low

If a request includes invalid parameter (Illegal sub command or non existing I/O address, etc), PLC returns a task code with error information such as task code error or not executed.

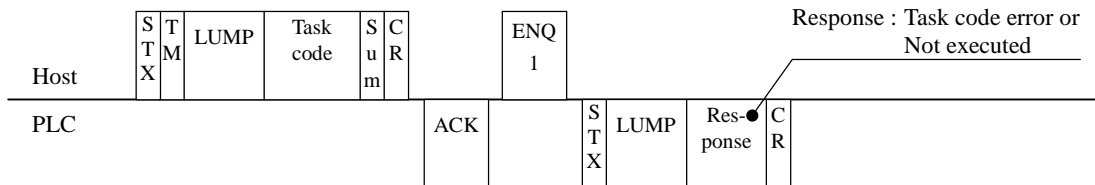

Figure.A.9 Transmission control procedure 1 Communication sequence diagram (Abnormal 2)

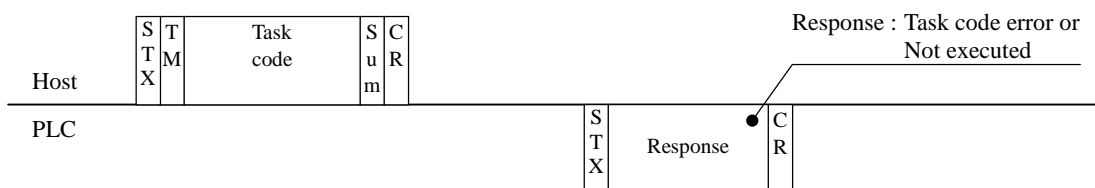

Figure.A.10 Transmission control procedure 2 Communication sequence diagram (Abnormal 2)

A.3.4 EH-SIO support task code details

Task code	H10	CPU status read	Classification	CPU Control																																																															
<p>■ Function Reads the CPU status, memory-load status and software version. This task code can also be executed when the CPU is not occupied.</p>																																																																			
<p>■ Execution condition</p> <table border="1"> <thead> <tr> <th>CPU Status Occupation</th> <th>STOP</th> <th>RUN</th> <th>HALT</th> <th>ERROR</th> </tr> </thead> <tbody> <tr> <td>READ occupation</td> <td>✓</td> <td>✓</td> <td>✓</td> <td>✓</td> </tr> <tr> <td>WRITE occupation</td> <td>✓</td> <td>✓</td> <td>✓</td> <td>✓</td> </tr> <tr> <td>Not occupied</td> <td>✓</td> <td>✓</td> <td>✓</td> <td>✓</td> </tr> </tbody> </table>					CPU Status Occupation	STOP	RUN	HALT	ERROR	READ occupation	✓	✓	✓	✓	WRITE occupation	✓	✓	✓	✓	Not occupied	✓	✓	✓	✓																																											
CPU Status Occupation	STOP	RUN	HALT	ERROR																																																															
READ occupation	✓	✓	✓	✓																																																															
WRITE occupation	✓	✓	✓	✓																																																															
Not occupied	✓	✓	✓	✓																																																															
<p>■ Request Format</p> <table border="1"> <tr> <td>H 1 0</td> <td>(a)</td> </tr> </table> <p>(a) Function selection (subcommand) 1] H00: Reads CPU status. 2] H01: Reads memory status. 3] H02: Reads system software version. 4] H03: Reads error code. 5] H04: Reads CPU name. 6] H05: Reads CPU specifications.</p>					H 1 0	(a)																																																													
H 1 0	(a)																																																																		
<p>■ Response Format 1] Reads CPU status (subcommand : H00)</p> <table border="1"> <tr> <td>(a)</td> <td>H 1 0</td> <td>(b)</td> <td>(c)</td> </tr> </table> <p>(a) Response task code (H00 when executed normally) For task codes other than the normal task codes, refer to the “response list by task code” at the end of this chapter.</p> <p>(b) The read CPU status</p> <p>(c) User program version (H00 to HFF) This value is counted up only when memory writing has occurred and the WRITE occupation is canceled (indicating the number of times WRITE occupation has occurred). This value is H00 upon power-up.</p> <p>CPU status (4 digits) (b) area details (response to the subcommand “H00”)</p> <table border="1"> <tr> <td>15</td><td>14</td><td>13</td><td>12</td><td>11</td><td>10</td><td>9</td><td>8</td><td>7</td><td>6</td><td>5</td><td>4</td><td>3</td><td>2</td><td>1</td><td>0</td> </tr> <tr> <td>0</td><td>0</td><td>0</td><td>0</td><td></td><td></td><td></td><td></td><td></td><td>0</td><td>0</td><td>0</td><td></td><td>0</td><td></td><td></td> </tr> </table> <p>bit8 ~ bit11 : CPU Type</p> <p>bit0 : RUN/STOP flag bit1 : Halt status flag bit3 : Error status flag bit7 : Battery error flag</p> <table> <tr> <td>bit11 to 8</td> <td>CPU type flag</td> <td>0011: EH-CPU516/548</td> </tr> <tr> <td>bit 0</td> <td>RUN/STOP flag</td> <td>Indicates the run/stop status of CPU. “1”: Run / “0”: Stop</td> </tr> <tr> <td>bit 1</td> <td>Halt status flag</td> <td>Indicates whether the CPU is halted or not. “1”: Halted / “0”: Not halted</td> </tr> <tr> <td>bit 2</td> <td>Unused (“0”)</td> <td></td> </tr> <tr> <td>bit 3</td> <td>Error status flag</td> <td>Indicates whether CPU is in the error status or not. “1”: Error / “0”: Normal When this flag is 1, error details may be determined by reading the CPU error code (refer to 4)].</td> </tr> <tr> <td>bit 4</td> <td>Unused (“0”)</td> <td></td> </tr> <tr> <td>bit 5</td> <td>Unused (“0”)</td> <td></td> </tr> <tr> <td>bit 6</td> <td>Unused (“0”)</td> <td></td> </tr> <tr> <td>bit 7</td> <td>Battery error flag</td> <td>Indicates whether CPU backup battery is normal or not. “1”: Battery is not installed or voltage is low. / “0”: Battery normal</td> </tr> </table>					(a)	H 1 0	(b)	(c)	15	14	13	12	11	10	9	8	7	6	5	4	3	2	1	0	0	0	0	0						0	0	0		0			bit11 to 8	CPU type flag	0011: EH-CPU516/548	bit 0	RUN/STOP flag	Indicates the run/stop status of CPU. “1”: Run / “0”: Stop	bit 1	Halt status flag	Indicates whether the CPU is halted or not. “1”: Halted / “0”: Not halted	bit 2	Unused (“0”)		bit 3	Error status flag	Indicates whether CPU is in the error status or not. “1”: Error / “0”: Normal When this flag is 1, error details may be determined by reading the CPU error code (refer to 4)].	bit 4	Unused (“0”)		bit 5	Unused (“0”)		bit 6	Unused (“0”)		bit 7	Battery error flag	Indicates whether CPU backup battery is normal or not. “1”: Battery is not installed or voltage is low. / “0”: Battery normal
(a)	H 1 0	(b)	(c)																																																																
15	14	13	12	11	10	9	8	7	6	5	4	3	2	1	0																																																				
0	0	0	0						0	0	0		0																																																						
bit11 to 8	CPU type flag	0011: EH-CPU516/548																																																																	
bit 0	RUN/STOP flag	Indicates the run/stop status of CPU. “1”: Run / “0”: Stop																																																																	
bit 1	Halt status flag	Indicates whether the CPU is halted or not. “1”: Halted / “0”: Not halted																																																																	
bit 2	Unused (“0”)																																																																		
bit 3	Error status flag	Indicates whether CPU is in the error status or not. “1”: Error / “0”: Normal When this flag is 1, error details may be determined by reading the CPU error code (refer to 4)].																																																																	
bit 4	Unused (“0”)																																																																		
bit 5	Unused (“0”)																																																																		
bit 6	Unused (“0”)																																																																		
bit 7	Battery error flag	Indicates whether CPU backup battery is normal or not. “1”: Battery is not installed or voltage is low. / “0”: Battery normal																																																																	

Task code	H10	CPU status read	Classification	CPU Control																																							
<p>■ Response Format</p> <p>2] Read memory status (subcommand H01)</p> <table border="1"> <tr> <td>(a)</td> <td>H 1 0</td> <td>(b)</td> <td>(c)</td> <td>(d)</td> </tr> </table> <p>(a) Response task code (H00 when executed normally) (b) Memory type (c) User memory capacity (number of steps) (d) Data memory capacity (number of words)</p> <p>Memory status (b), (c), (d) area details (response to the subcommand "H01")</p> <table border="1"> <thead> <tr> <th>Item</th> <th>Contents</th> <th>Description</th> <th>Remarks</th> </tr> </thead> <tbody> <tr> <td rowspan="2">Memory Type (b)</td> <td>H00</td> <td>Memory error</td> <td></td> </tr> <tr> <td>H02</td> <td>RAM memory</td> <td></td> </tr> <tr> <td rowspan="2">User memory capacity (c)</td> <td>H0040</td> <td>16 k steps</td> <td>EH-CPU516</td> </tr> <tr> <td>H00C0</td> <td>48 k steps</td> <td>EH-CPU548</td> </tr> <tr> <td rowspan="2">Data memory capacity (d)</td> <td>H0094</td> <td>22 kW</td> <td>EH-CPU516</td> </tr> <tr> <td>H0100</td> <td>49 kW</td> <td>EH-CPU548</td> </tr> </tbody> </table> <p>3] System software version (response to the subcommand H02)</p> <table border="1"> <tr> <td>(a)</td> <td>H 1 0</td> <td>(b)</td> </tr> </table> <p>(a) Response task code (H00 when executed normally) (b) Version (4 digit BCD) This is the version of the system software (ROM) for CPU</p> <p>4] Read error code (subcommand H03)</p> <table border="1"> <tr> <td>(a)</td> <td>H 1 0</td> <td>(b)</td> </tr> </table> <p>(a) Response task code (H00 when executed normally) (b) CPU error code (2 digit hexadecimal) This is the same code as the contents of special internal output WRF000.</p> <p>5] Read CPU name (subcommand H04)</p> <table border="1"> <tr> <td>(a)</td> <td>H 1 0</td> <td>(b)</td> </tr> </table> <p>(a) Response task code (H00 when executed normally) (b) CPU name (16 ASCII-code characters) If it is less than 16 characters, Null (H20) are added until 16 characters are reached. EH-CPU516/548 ... "H-302"</p>					(a)	H 1 0	(b)	(c)	(d)	Item	Contents	Description	Remarks	Memory Type (b)	H00	Memory error		H02	RAM memory		User memory capacity (c)	H0040	16 k steps	EH-CPU516	H00C0	48 k steps	EH-CPU548	Data memory capacity (d)	H0094	22 kW	EH-CPU516	H0100	49 kW	EH-CPU548	(a)	H 1 0	(b)	(a)	H 1 0	(b)	(a)	H 1 0	(b)
(a)	H 1 0	(b)	(c)	(d)																																							
Item	Contents	Description	Remarks																																								
Memory Type (b)	H00	Memory error																																									
	H02	RAM memory																																									
User memory capacity (c)	H0040	16 k steps	EH-CPU516																																								
	H00C0	48 k steps	EH-CPU548																																								
Data memory capacity (d)	H0094	22 kW	EH-CPU516																																								
	H0100	49 kW	EH-CPU548																																								
(a)	H 1 0	(b)																																									
(a)	H 1 0	(b)																																									
(a)	H 1 0	(b)																																									

Task code	H10	CPU status read						Classification	CPU Control																	
<p>■ Response Format</p> <p>5] Read CPU specifications (subcommand H05)</p> <table border="1" style="margin-left: 40px;"> <tr> <td>(a)</td> <td>H 1 0</td> <td>(b)</td> <td>(c)</td> <td>(d)</td> <td>(e)</td> <td>(f)</td> <td>(g)</td> <td>(h)</td> <td>(i)</td> </tr> </table> <p>(a) Response task code (H00 when executed normally)</p> <p>(b) CPU name (16 ASCII-code characters) If it is less than 16 characters, Null (H20) are added until 16 characters are reached. EH-CPU516/548 ... "H-302"</p> <p>(c) System software version (4 digit BCD)</p> <p>(d) Task code level (4 digit BCD) Task code level - Integer parts (2 digit) + Decimal place (2 digit) EH-CPU516/548 ... "H0610"</p> <p>(e) CPU Hardware information (2 digit hexadecimal) EH-CPU516/548 ... "H0001"</p> <p>(f) Supported high function module information (2 digit hexadecimal) EH-CPU516/548 ... "H000E"</p> <p>(g) Supported language information (2 digit hexadecimal) EH-CPU516/548 ... "H0001"</p> <p>(h) CPU function information (2 digit hexadecimal) EH-CPU516/548 ... "H0000"</p> <p>(i) I/O list (6 digit hexadecimal (I/O code + number of I/O points) x for I/O list number)</p> <table border="1" style="margin-left: 40px;"> <tr> <td>α</td> <td>β</td> <td>α^1</td> <td>β^1</td> <td>⋮</td> <td>α^n</td> <td>β^n</td> </tr> </table> <p>α : I/O Code It is based on Hi-Protocol. β : Number of I/O points As for I/O which cannot be used, I/O points are set to 0000H. A timer / counter is represented with TD.</p>										(a)	H 1 0	(b)	(c)	(d)	(e)	(f)	(g)	(h)	(i)	α	β	α^1	β^1	⋮	α^n	β^n
(a)	H 1 0	(b)	(c)	(d)	(e)	(f)	(g)	(h)	(i)																	
α	β	α^1	β^1	⋮	α^n	β^n																				

Task code	H16	CPU occupation / cancel	Classification	CPU Control																																																																		
<p>■ Function Declares that the user memory will be accessed. User memory cannot be accessed by host unless the CPU is occupied in case of using H4x task code. Also, depending on the function selection, it performs the same processing as the parameter modification completion processing (task code H27).</p>																																																																						
<p>■ Execution condition</p> <table border="1"> <thead> <tr> <th rowspan="2">Occupancy \ CPU Status</th> <th>STOP</th> <th>RUN</th> <th>HALT</th> <th>ERROR</th> <th>Function (subcommand)</th> </tr> </thead> <tbody> <tr> <td>READ occupation</td> <td>✓</td> <td>✓</td> <td>✓</td> <td>✓</td> <td>00H</td> </tr> <tr> <td></td> <td>✓</td> <td>✓</td> <td>✓</td> <td>✓</td> <td>01H</td> </tr> <tr> <td></td> <td>-</td> <td>-</td> <td>-</td> <td>-</td> <td>02H</td> </tr> <tr> <td></td> <td>✓</td> <td>✓</td> <td>✓</td> <td>✓</td> <td>05H</td> </tr> <tr> <td></td> <td>✓*1</td> <td>✓*1</td> <td>✓*1</td> <td>✓*1</td> <td>06H</td> </tr> <tr> <td>WRITE occupation</td> <td>✓</td> <td>✓</td> <td>✓</td> <td>✓</td> <td>00H</td> </tr> <tr> <td></td> <td>-</td> <td>-</td> <td>-</td> <td>-</td> <td>01H</td> </tr> <tr> <td></td> <td>✓</td> <td>✓</td> <td>✓</td> <td>✓</td> <td>02H</td> </tr> <tr> <td></td> <td>✓</td> <td>✓</td> <td>✓</td> <td>✓</td> <td>05H</td> </tr> <tr> <td></td> <td>✓</td> <td>✓</td> <td>✓</td> <td>✓</td> <td>06H</td> </tr> </tbody> </table> <p>*1: It cannot be executed while the CPU is READ-occupied by another station.</p>					Occupancy \ CPU Status	STOP	RUN	HALT	ERROR	Function (subcommand)	READ occupation	✓	✓	✓	✓	00H		✓	✓	✓	✓	01H		-	-	-	-	02H		✓	✓	✓	✓	05H		✓*1	✓*1	✓*1	✓*1	06H	WRITE occupation	✓	✓	✓	✓	00H		-	-	-	-	01H		✓	✓	✓	✓	02H		✓	✓	✓	✓	05H		✓	✓	✓	✓	06H
Occupancy \ CPU Status	STOP	RUN	HALT	ERROR		Function (subcommand)																																																																
	READ occupation	✓	✓	✓	✓	00H																																																																
	✓	✓	✓	✓	01H																																																																	
	-	-	-	-	02H																																																																	
	✓	✓	✓	✓	05H																																																																	
	✓*1	✓*1	✓*1	✓*1	06H																																																																	
WRITE occupation	✓	✓	✓	✓	00H																																																																	
	-	-	-	-	01H																																																																	
	✓	✓	✓	✓	02H																																																																	
	✓	✓	✓	✓	05H																																																																	
	✓	✓	✓	✓	06H																																																																	
<p>■ Request format</p> <table border="1"> <tr> <td>H</td> <td>1</td> <td>6</td> <td>(a)</td> </tr> </table> <p>(a) Function selection (subcommand) 1] H01: READ occupation 2] H02: WRITE occupation 3] H05: Modifies the local station occupation mode from WRITE occupation to READ occupation. 4] H06: Modifies the local station occupation mode from READ occupation to WRITE occupation. 5] H00: Cancels the local station occupation.</p>					H	1	6	(a)																																																														
H	1	6	(a)																																																																			
<p>■ Response format</p> <table border="1"> <tr> <td>(a)</td> <td>H</td> <td>1</td> <td>6</td> <td>(b)</td> </tr> </table> <p>(a) Response task code (H00 when executed normally) For task codes other than the normal task codes, refer to the “response list by task code” at the end of this chapter. (b) User program version (H00 to HFF)</p> <p>1] READ occupation (subcommand H01) This command is used when the local station is not occupying the CPU if performing tasks such as reading the user program, monitoring and setting the data memory or the I/O.</p> <p>2] WRITE occupation (subcommand H02) This command is used when writing the user program if the local station is not WRITE-occupying the CPU. This command cannot be used when another station is occupying the CPU.</p> <p>3] Occupation mode modification (modification from WRITE occupation to READ occupation) (subcommand H05) Modifies the CPU occupation mode of the local station to the READ occupation. This command cannot be executed when the local station is not occupying the CPU. When modifying from WRITE occupation to READ occupation, the parameter modification completion processing is performed.</p> <p>4] Occupation mode modification(modification from READ occupation to WRITE occupation) (subcommand H06) Modifies the CPU occupation mode of the local station to WRITE occupation. This command cannot be executed when the local station is not occupying the CPU. This command cannot be executed when another station is occupying the CPU.</p> <p>5] Occupation cancel (subcommand H00) Cancels the local station CPU occupation. When canceling the WRITE occupation, the parameter modification completion processing is performed.</p>					(a)	H	1	6	(b)																																																													
(a)	H	1	6	(b)																																																																		

Task code	H17	Forced cancel of occupation	Classification	CPU Control
-----------	-----	-----------------------------	----------------	-------------

■ Function

Forces the cancel of CPU occupation. This command is used in situations such as when another programming device has gone down due to an error while occupying the user memory of the CPU (function selection H00). When connecting the host to the CPU and occupying it for the first time, use function selection H01 so the local occupation status is canceled forcibly. This task code can also be executed when the CPU is not occupied.

■ Execution condition

	CPU Status	STOP	RUN	HALT	ERROR
Occupation					
READ occupation		✓	✓	✓	✓
WRITE occupation		✓	✓	✓	✓
Not occupied		✓	✓	✓	✓

■ Request format

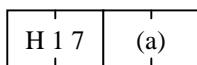

(a) Function selection (subcommand)

- 1] H00: Forced cancel of all occupation
- 2] H01: Forced cancel of local station occupation

■ Response format

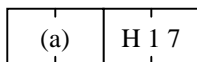

(a) Response task code (H00 when executed normally)

For task codes other than the normal task codes, refer to the “response list by task code” at the end of this chapter.

With forced cancel, if there are modification in the parameter area, the same processing as parameter modification completion processing is performed (refer to the task code H27) as well as the canceling of memory occupation.

1] Forced cancel of all occupation (subcommand H00)

All occupation is canceled unconditionally, so when this command has been executed the peripheral that is reading the user memory, for example, will not be able to perform reading. Therefore, verify the registered peripherals by monitoring the occupation table (WRF040 to WRF04B) when executing this command.

Member registration area

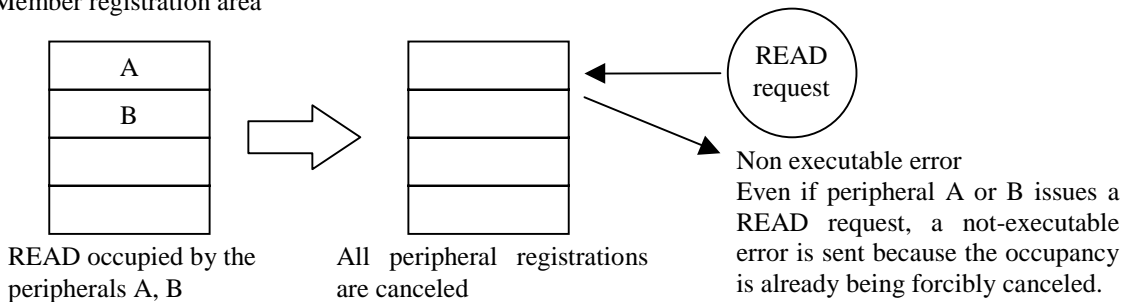

2] Forced cancel of local station occupation (subcommand H01)

Cancels the occupation of the local station. The occupation of other stations are maintained.

Member registration area

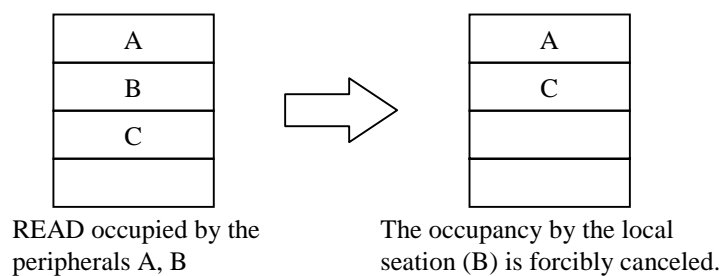

Task code	H40	Monitoring with I/O number designation (Series N points)	Classification	I/O Control																											
<p>■ Function</p> <p>Reads N continuous points (words) of monitor data, starting with the specified I/O number.</p> <p>* This task code can also be executed when the CPU is not occupied. However, the response task code will be "H02" (local station is not occupying the CPU).</p> <p>* The I/O data of EH-150 outside the range returns all off (0).</p>																															
<p>■ Execution condition</p> <table border="1"> <thead> <tr> <th rowspan="2">Occupation \ CPU Status</th> <th>STOP</th> <th>RUN</th> <th>HALT</th> <th>ERROR</th> </tr> </thead> <tbody> <tr> <td>READ occupation</td> <td>✓</td> <td>✓</td> <td>✓</td> <td>✓</td> </tr> <tr> <td>WRITE occupation</td> <td>✓</td> <td>✓</td> <td>✓</td> <td>✓</td> </tr> <tr> <td>Not occupied</td> <td>✓</td> <td>✓</td> <td>✓</td> <td>✓</td> </tr> </tbody> </table>					Occupation \ CPU Status	STOP	RUN	HALT	ERROR	READ occupation	✓	✓	✓	✓	WRITE occupation	✓	✓	✓	✓	Not occupied	✓	✓	✓	✓							
Occupation \ CPU Status	STOP	RUN	HALT	ERROR																											
	READ occupation	✓	✓	✓	✓																										
WRITE occupation	✓	✓	✓	✓																											
Not occupied	✓	✓	✓	✓																											
<p>■ Request format</p> <table border="1"> <tr> <td>H 4 0</td> <td>(a)</td> <td>(b)</td> <td>(c)</td> </tr> </table> <p>(a) I/O code (refer to the I/O code table) (b) I/O number (refer to I/O number decimal/hexadecimal conversion chart) (c) Number of bits H01 to HF0 (1 to 240) Number of words H01 to H78 (1 to 120)</p>					H 4 0	(a)	(b)	(c)																							
H 4 0	(a)	(b)	(c)																												
<p>■ Response format</p> <table border="1"> <tr> <td>(a)</td> <td>H 4 0</td> <td>(b)</td> </tr> </table> <p>(a) Response task code (H00 when executed normally) For task codes other than the normal task codes, refer to the "response list by task code" at the end of this chapter.</p> <p>(b) Monitor data (Bit data)</p> <p style="text-align: center;">Number of points / 8</p> <table border="1"> <tr> <td colspan="8">Number of points / 8</td> </tr> <tr> <td>1st point</td> <td>2nd point</td> <td>3rd point</td> <td></td> <td></td> <td></td> <td></td> <td>8th point</td> </tr> </table> <p>Binary image (H00 to HFF) bit7 bit0</p> <p>* When the number of monitor points is less than 8 points, the open bits are set to "0" (H00 to HFF).</p> <p>(Word data)</p> <p style="text-align: center;">Number of words</p> <table border="1"> <tr> <td colspan="4">Number of words</td> </tr> <tr> <td>H</td> <td>L</td> <td></td> <td></td> </tr> </table> <p>1st word Nth word Binary image (H0000 to HFFFF)</p>					(a)	H 4 0	(b)	Number of points / 8								1st point	2nd point	3rd point					8th point	Number of words				H	L		
(a)	H 4 0	(b)																													
Number of points / 8																															
1st point	2nd point	3rd point					8th point																								
Number of words																															
H	L																														
<p>■ Example</p> <p>Read 16 words from WR20. (WR20=H1234, WR21 - 2F=H0000)</p> <p>Request : STX 2 FFFF0000 40 0A 000020 10 62 CR</p> <p>Request (ASCII) : 02 32 4646464630303030 3430 3041 30303030303230 3130 3632 0D</p> <p>Response : STX FFFF0000 00 40 1234 0000 0000 0000 00000000 SUM CR</p>																															

Task code	H42	Forced set/reset with I/O number designation (Series N points)	Classification	I/O Control
-----------	-----	---	----------------	-------------

■ Function

Forcibly sets and resets the designated data in N continuous points (words) of data area, starting with the designated I/O.

■ Execution condition

CPU Status	STOP	RUN	HALT	ERROR
Occupation				
READ occupation	✓	✓	✓	✓
WRITE occupation	✓	✓	✓	✓
Not occupied	-	-	-	-

■ Request format

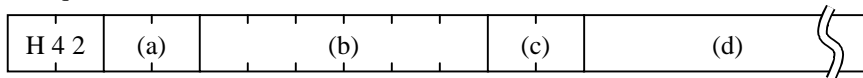

- (a) I/O code (refer to the I/O code table)
- (b) I/O number (refer to I/O number decimal/hexadecimal conversion chart)
- (c) Number of bits H01 to HC8 (1 to 200)
Number of words H01 to H64 (1 to 100)
- (d) Set / reset data
(Bit data)

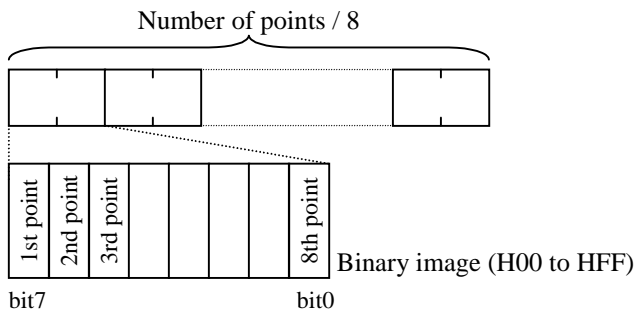

* When the number of set/reset points is less than 8 points, the open bits are set to "0" (H00 to HFF).

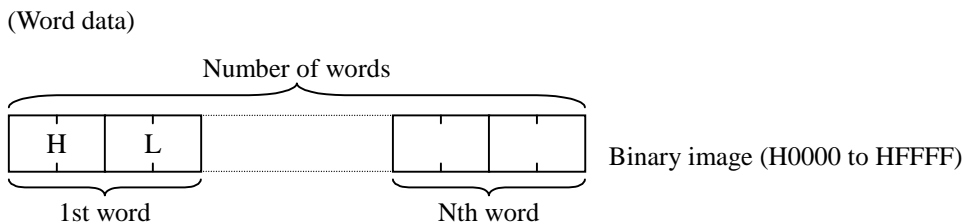

■ Response format

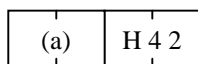

- (a) Response task code (H00 when executed normally)
For task codes other than the normal task codes, refer to the "response list by task code" at the end of this chapter.

■ Example

Write 2 words to WR200. (WR200=H1234, WR201=H5678)

Request : STX 2 FFFF0000 42 0A 000200 02 1234 5678 09 CR

Request (ASCII) : 02 32 4646464630303030 3432 3041 303030323030 3032 31323334 35363738 3039 0D

Response : STX FFFF0000 00 42 SUM CR

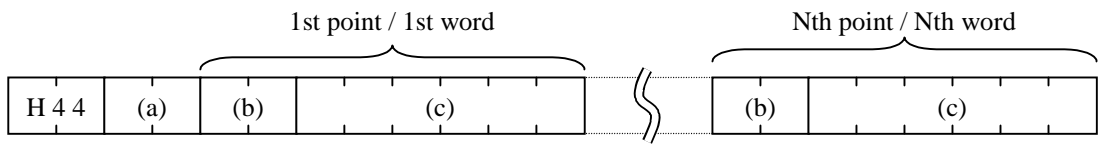
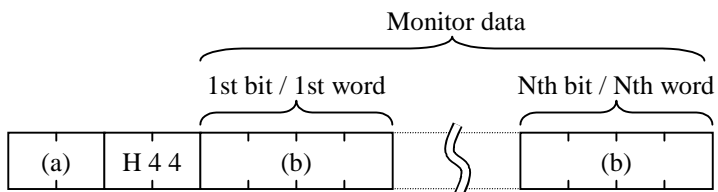
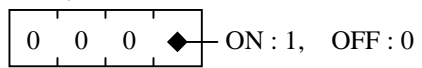
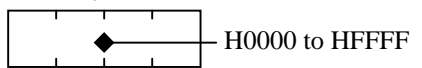
Task code	H44	Monitoring with I/O number designation (Random N points)	Classification	I/O Control																									
<p>■ Function</p> <p>Reads the monitor data by designating N random points (words) of I/O numbers.</p> <p>* This task code can also be executed when the CPU is not occupied. However, the response task code will be "H02" (local station is not occupying the CPU).</p> <p>* The I/O data of EH-150 outside the range returns all off (0).</p>																													
<p>■ Execution condition</p> <table border="1"> <thead> <tr> <th>CPU Status</th> <th>STOP</th> <th>RUN</th> <th>HALT</th> <th>ERROR</th> </tr> </thead> <tbody> <tr> <td>Occupation</td> <td></td> <td></td> <td></td> <td></td> </tr> <tr> <td>READ occupation</td> <td>✓</td> <td>✓</td> <td>✓</td> <td>✓</td> </tr> <tr> <td>WRITE occupation</td> <td>✓</td> <td>✓</td> <td>✓</td> <td>✓</td> </tr> <tr> <td>Not occupied</td> <td>✓</td> <td>✓</td> <td>✓</td> <td>✓</td> </tr> </tbody> </table>					CPU Status	STOP	RUN	HALT	ERROR	Occupation					READ occupation	✓	✓	✓	✓	WRITE occupation	✓	✓	✓	✓	Not occupied	✓	✓	✓	✓
CPU Status	STOP	RUN	HALT	ERROR																									
Occupation																													
READ occupation	✓	✓	✓	✓																									
WRITE occupation	✓	✓	✓	✓																									
Not occupied	✓	✓	✓	✓																									
<p>■ Request format</p>  <p>(a) Number of bits / Number of words H01 to H3C (1 to 60)</p> <p>(b) I/O code (refer to the I/O code table)</p> <p>(c) I/O number (refer to I/O number decimal/hexadecimal conversion chart)</p>																													
<p>■ Response format</p>  <p>(a) Response task code (H00 when executed normally) For task codes other than the normal task codes, refer to the "response list by task code" at the end of this chapter.</p> <p>(b) Monitor data</p> <p>(Bit data)</p>  <p>(Word data)</p> 																													
<p>■ Example</p> <p>Read 2 words from WR4 and WM56. (WR4=H3333, WM56=H5555)</p> <p>Request : STX 2 FFFF0000 44 02 0A 000004 0C 000056 07 CR</p> <p>Request (ASCII) : 02 32 4646464630303030 3434 3032 3041 303030303034 3043 30303030 35363037 0D</p> <p>Response : STX FFFF0000 00 44 3333 5555 SUM CR</p>																													

Task code	H45	Forced set/reset with I/O number designation (Random N points)	Classification	I/O Control																									
<p>■ Function</p> <p>Designates N points (words) of I/O numbers randomly, and forcibly sets the designated data or resets the data area.</p>																													
<p>■ Execution condition</p> <table border="1"> <thead> <tr> <th>CPU Status</th> <th>STOP</th> <th>RUN</th> <th>HALT</th> <th>ERROR</th> </tr> </thead> <tbody> <tr> <td>Occupation</td> <td></td> <td></td> <td></td> <td></td> </tr> <tr> <td>READ occupation</td> <td>✓</td> <td>✓</td> <td>✓</td> <td>✓</td> </tr> <tr> <td>WRITE occupation</td> <td>✓</td> <td>✓</td> <td>✓</td> <td>✓</td> </tr> <tr> <td>Not occupied</td> <td>-</td> <td>-</td> <td>-</td> <td>-</td> </tr> </tbody> </table>					CPU Status	STOP	RUN	HALT	ERROR	Occupation					READ occupation	✓	✓	✓	✓	WRITE occupation	✓	✓	✓	✓	Not occupied	-	-	-	-
CPU Status	STOP	RUN	HALT	ERROR																									
Occupation																													
READ occupation	✓	✓	✓	✓																									
WRITE occupation	✓	✓	✓	✓																									
Not occupied	-	-	-	-																									
<p>■ Request format</p> <p>(a) Number of bits / Number of words H01 to H28 (1 to 40)</p> <p>(b) I/O code (refer to the I/O code table)</p> <p>(c) I/O number (refer to I/O number decimal/hexadecimal conversion chart)</p> <p>(d) Set / reset data</p> <p>(Bit data)</p> <p>(Word data)</p>																													
<p>■ Response format</p> <p>(a) Response task code</p> <p>For task codes other than the normal task codes, refer to the “response list by task code” at the end of this chapter.</p> <p>* The EH-150 returns “H00” (normal execution) even for I/Os that are out of range.</p>																													
<p>■ Example</p> <p>Write 2 words to WR100 and WR10A. (WR4=HABCD, WR10A=HDCBA)</p> <p>Request : STX 2 FFFF0000 45 02 0A 000100 ABCD 0A 00010A DCBA 1E CR</p> <p>Request (ASCII) : 02 32 4646464630303030 3435 3032 3041 303030313030 41424344 3041 303030313041 44434241 3145 0D</p> <p>Response : STX FFFF0000 00 45 SUM CR</p>																													

Task code	HA0	Monitoring with I/O number designation (Series N points)	Classification	I/O Control																								
<p>■ Function Reads N continuous points (words) of monitor data, starting with the designated I/O number. * This task code can also be executed when the CPU is not occupied. * The I/O data of EH-150 outside the range returns all off (0).</p>																												
<p>■ Execution condition</p> <table border="1"> <thead> <tr> <th rowspan="2">Occupation</th> <th colspan="4">CPU Status</th> </tr> <tr> <th>STOP</th> <th>RUN</th> <th>HALT</th> <th>ERROR</th> </tr> </thead> <tbody> <tr> <td>READ occupation</td> <td>✓</td> <td>✓</td> <td>✓</td> <td>✓</td> </tr> <tr> <td>WRITE occupation</td> <td>✓</td> <td>✓</td> <td>✓</td> <td>✓</td> </tr> <tr> <td>Not occupied</td> <td>✓</td> <td>✓</td> <td>✓</td> <td>✓</td> </tr> </tbody> </table>					Occupation	CPU Status				STOP	RUN	HALT	ERROR	READ occupation	✓	✓	✓	✓	WRITE occupation	✓	✓	✓	✓	Not occupied	✓	✓	✓	✓
Occupation	CPU Status																											
	STOP	RUN	HALT	ERROR																								
READ occupation	✓	✓	✓	✓																								
WRITE occupation	✓	✓	✓	✓																								
Not occupied	✓	✓	✓	✓																								
<p>■ Request format</p> <table border="1"> <tr> <td>H A 0</td> <td>(a)</td> <td>(b)</td> <td>(c)</td> </tr> </table> <p>(a) I/O code (refer to the I/O code table) (b) I/O number (refer to I/O number decimal/hexadecimal conversion chart) (c) Number of bits H01 to HF0 (1 to 240) Number of words H01 to H78 (1 to 120)</p>					H A 0	(a)	(b)	(c)																				
H A 0	(a)	(b)	(c)																									
<p>■ Response format</p> <table border="1"> <tr> <td>(a)</td> <td>H A 0</td> <td>(b)</td> </tr> </table> <p>(a) Response task code (H00 when executed normally) For task codes other than the normal task codes, refer to the “response list by task code” at the end of this chapter.</p> <p>(b) Monitor data (Bit data)</p> <p>* When the number of monitor points is less than 8 points, the open bits are set to “0” (H00 to HFF).</p> <p>(Word data)</p>					(a)	H A 0	(b)																					
(a)	H A 0	(b)																										
<p>■ Example Read 16 points from M40. (M40=1, M41 - M4F=0)</p> <p>Request : STX 2 FFFF0000 A0 04 000040 10 64 CR Request (ASCII) : 02 32 4646464630303030 4130 3034 3030303030303430 3130 3634 0D Response : STX FFFF0000 00 A0 8000 BCC CR</p>																												

Task code	HA2	Forced set/reset with I/O number designation (Series N points)	Classification	I/O Control																									
<p>■ Function Forcibly sets and resets the designated data in N continuous points (words) of data area, starting with the specified I/O. * This task code can also be executed when the CPU is not occupied.</p>																													
<p>■ Execution condition</p> <table border="1"> <thead> <tr> <th>CPU Status</th> <th>STOP</th> <th>RUN</th> <th>HALT</th> <th>ERROR</th> </tr> </thead> <tbody> <tr> <td>Occupation</td> <td></td> <td></td> <td></td> <td></td> </tr> <tr> <td>READ occupation</td> <td>✓</td> <td>✓</td> <td>✓</td> <td>✓</td> </tr> <tr> <td>WRITE occupation</td> <td>✓</td> <td>✓</td> <td>✓</td> <td>✓</td> </tr> <tr> <td>Not occupied</td> <td>✓</td> <td>✓</td> <td>✓</td> <td>✓</td> </tr> </tbody> </table>					CPU Status	STOP	RUN	HALT	ERROR	Occupation					READ occupation	✓	✓	✓	✓	WRITE occupation	✓	✓	✓	✓	Not occupied	✓	✓	✓	✓
CPU Status	STOP	RUN	HALT	ERROR																									
Occupation																													
READ occupation	✓	✓	✓	✓																									
WRITE occupation	✓	✓	✓	✓																									
Not occupied	✓	✓	✓	✓																									
<p>■ Request format</p> <div style="border: 1px solid black; padding: 5px; margin-bottom: 10px;"> <table style="width: 100%; border-collapse: collapse;"> <tr> <td style="width: 10%; border: 1px solid black; text-align: center;">H A 2</td> <td style="width: 10%; border: 1px solid black; text-align: center;">(a)</td> <td style="width: 10%; border: 1px solid black; text-align: center;">(b)</td> <td style="width: 10%; border: 1px solid black; text-align: center;">(c)</td> <td style="width: 10%; border: 1px solid black; text-align: center;">(d)</td> <td style="width: 50%; border: none;"></td> </tr> </table> </div> <p>(a) I/O code (refer to the I/O code table) (b) I/O number (refer to I/O number decimal/hexadecimal conversion chart) (c) Number of bits H01 to HC8 (1 to 200) Number of words H01 to H64 (1 to 100) (d) Set / reset data (Bit data)</p> <div style="margin-bottom: 10px;"> <p style="text-align: center;">Number of points / 8</p> </div> <div style="margin-bottom: 10px;"> <p style="text-align: center;">Binary image (H00 to HFF) (Word data)</p> </div> <p style="text-align: right;">* When the number of set/reset points is less than 8 points, the open bits are set to "0" (H00 to HFF).</p> <div style="margin-bottom: 10px;"> <p style="text-align: center;">Number of words</p> </div>					H A 2	(a)	(b)	(c)	(d)																				
H A 2	(a)	(b)	(c)	(d)																									
<p>■ Response format</p> <div style="display: flex; align-items: center; margin-bottom: 10px;"> <div style="border: 1px solid black; padding: 5px; margin-right: 20px;"> <table style="width: 100%; border-collapse: collapse;"> <tr> <td style="width: 10%; text-align: center;">(a)</td> <td style="width: 10%; text-align: center;">H A 2</td> </tr> </table> </div> <div> <p>(a) Response task code (H00 when executed normally) For task codes other than the normal task codes, refer to the "response list by task code" at the end of this chapter.</p> </div> </div>					(a)	H A 2																							
(a)	H A 2																												
<p>■ Example Write "1" to M50 - M54.</p> <table style="width: 100%; border-collapse: collapse;"> <tr> <td style="width: 30%;">Request</td> <td>: STX 2 FFFF0000 A2 04 000050 05 F8 E9 CR</td> </tr> <tr> <td>Request (ASCII)</td> <td>: 02 32 4646464630303030 4132 3034 303030303530 3035 4638 4539 0D</td> </tr> <tr> <td>Response</td> <td>: STX FFFF0000 00 A2 SUM C</td> </tr> </table>					Request	: STX 2 FFFF0000 A2 04 000050 05 F8 E9 CR	Request (ASCII)	: 02 32 4646464630303030 4132 3034 303030303530 3035 4638 4539 0D	Response	: STX FFFF0000 00 A2 SUM C																			
Request	: STX 2 FFFF0000 A2 04 000050 05 F8 E9 CR																												
Request (ASCII)	: 02 32 4646464630303030 4132 3034 303030303530 3035 4638 4539 0D																												
Response	: STX FFFF0000 00 A2 SUM C																												

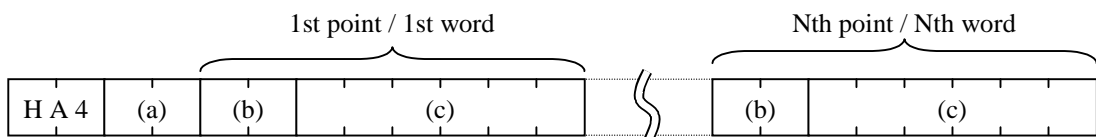
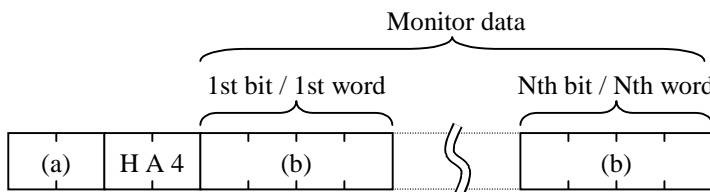
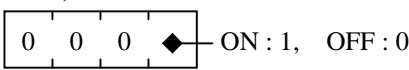
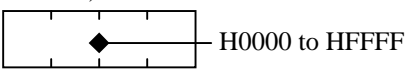
Task code	HA4	Monitoring with I/O number designation (Random N points)	Classification	I/O Control																				
<p>■ Function</p> <p>Reads the monitor data by designating N random points (words) of I/O numbers.</p> <p>This task code can also be executed when the CPU is not occupied.</p> <p>* The I/O data of EH-150 outside the range returns all off (0).</p>																								
<p>■ Execution condition</p> <table border="1"> <thead> <tr> <th>CPU Status \ Occupation</th> <th>STOP</th> <th>RUN</th> <th>HALT</th> <th>ERROR</th> </tr> </thead> <tbody> <tr> <td>READ occupation</td> <td>✓</td> <td>✓</td> <td>✓</td> <td>✓</td> </tr> <tr> <td>WRITE occupation</td> <td>✓</td> <td>✓</td> <td>✓</td> <td>✓</td> </tr> <tr> <td>Not occupied</td> <td>✓</td> <td>✓</td> <td>✓</td> <td>✓</td> </tr> </tbody> </table>					CPU Status \ Occupation	STOP	RUN	HALT	ERROR	READ occupation	✓	✓	✓	✓	WRITE occupation	✓	✓	✓	✓	Not occupied	✓	✓	✓	✓
CPU Status \ Occupation	STOP	RUN	HALT	ERROR																				
READ occupation	✓	✓	✓	✓																				
WRITE occupation	✓	✓	✓	✓																				
Not occupied	✓	✓	✓	✓																				
<p>■ Request format</p>  <p>(a) Number of bits / Number of words H01 to H3C (1 to 60)</p> <p>(b) I/O code (refer to the I/O code table)</p> <p>(c) I/O number (refer to I/O number decimal/hexadecimal conversion chart)</p>																								
<p>■ Response format</p>  <p>(a) Response task code (H00 when executed normally) For task codes other than the normal task codes, refer to the “response list by task code” at the end of this chapter.</p> <p>(b) Monitor data</p> <p>(Bit data)</p>  <p>(Word data)</p> 																								
<p>■ Example</p> <p>Read 2 points from X7 and X14. (X7=1, X14=1)</p> <p>Request : STX 2 FFFF0000 A4 02 00 000007 00 00000E FD CR</p> <p>Request (ASCII) : 02 32 4646464630303030 4134 3032 3030 30303030303037 3030 303030303045 4644 0D</p> <p>Response : STX FFFF0000 00 A4 0001 0001 SUM CR</p>																								

Task code	HA5	Forced set/reset with I/O number designation (Random N points)	Classification	I/O Control																									
<p>■ Function Designates N points (words) of I/O numbers randomly, and forcibly sets the designated data or resets the data area. * This task code can also be executed when the CPU is not occupied.</p>																													
<p>■ Execution condition</p> <table border="1"> <thead> <tr> <th>CPU Status</th> <th>STOP</th> <th>RUN</th> <th>HALT</th> <th>ERROR</th> </tr> </thead> <tbody> <tr> <td>Occupation</td> <td></td> <td></td> <td></td> <td></td> </tr> <tr> <td> READ occupation</td> <td>✓</td> <td>✓</td> <td>✓</td> <td>✓</td> </tr> <tr> <td> WRITE occupation</td> <td>✓</td> <td>✓</td> <td>✓</td> <td>✓</td> </tr> <tr> <td> Not occupied</td> <td>✓</td> <td>✓</td> <td>✓</td> <td>✓</td> </tr> </tbody> </table>					CPU Status	STOP	RUN	HALT	ERROR	Occupation					READ occupation	✓	✓	✓	✓	WRITE occupation	✓	✓	✓	✓	Not occupied	✓	✓	✓	✓
CPU Status	STOP	RUN	HALT	ERROR																									
Occupation																													
READ occupation	✓	✓	✓	✓																									
WRITE occupation	✓	✓	✓	✓																									
Not occupied	✓	✓	✓	✓																									
<p>■ Request format</p> <p>(a) Number of bits / Number of words H01 to H28 (1 to 40) (b) I/O code (refer to the I/O code table) (c) I/O number (refer to I/O number decimal/hexadecimal conversion chart) (d) Set / reset data</p> <p>(Bit data) ON : 1, OFF : 0</p> <p>(Word data) H0000 to HFFFF</p>																													
<p>■ Response format</p> <p>(a) Response task code For task codes other than the normal task codes, refer to the “response list by task code” at the end of this chapter. * The EH-150 returns “H00” (normal execution) even for I/Os that are out of range.</p>																													
<p>■ Example Write “1” to R7 and RE.</p> <p>Request : STX 2 FFFF0000 A5 02 02 000007 0001 02 00000E 0001 84 CR Request (ASCII) : 02 32 4646464630303030 4135 3032 3032 303030303037 30303031 3032 303030303045 30303031 3834 0D Response : STX FFFF0000 00 A5 SUM CR</p>																													

Table. A.9 Task code response list (1 / 2)

Task code	Subcommand		Response task code		Return code		Error cause
		Code		Code		Code	
H10	Status	H00	Normal execution	H00			
	Memory status	H01	Normal execution	H00			
	Software version	H02	Normal execution	H00			
	CPU error code	H03	Normal execution	H00			
	Call CPU name	H04	Normal execution	H00			
	CPU specification	H05	Normal execution	H00			
	Undefined	H06 to HFF	Abnormal task code	H01	Undefined subcommand	H02	Undefined subcommand is set.
	None		Abnormal task code	H01	Abnormal number of steps/words	H05	Only the task code is input.
H16	Cancel occupation	H00	Normal execution	H00			
	READ occupation	H01	Normal execution	H00			
			Not-executable	H03	Occupation code mismatch	H04	Local station is WRITE-occupying CPU.
					READ occupation maximum exceeded	H06	Already READ-occupied by the other four stations.
					Occupied by another station	H08	Another station is WRITE-occupying CPU.
	WRITE occupation	H02	Normal execution	H00			
			Not-executable	H03	Occupation code mismatch	H03	Local station is READ-occupying CPU.
					Occupied by another station	H08	CPU is occupied by another station.
	Occupation mode modification (WRITE → READ)	H05	Normal execution	H00			
			Not-executable	H03	Not occupied	H07	Local station is not occupying the CPU.
	Occupation mode modification (READ → WRITE)	H06	Normal execution	H00			
			Not-executable	H03	Not occupied	H07	Local station is not occupying the CPU.
					Occupied by another station	H08	CPU is occupying by another station.
	Undefined	H03, H04, H07 to HFF	Abnormal task code	H01	Undefined subcommand	H02	Undefined subcommand is set.
None		Abnormal task code	H01	Abnormal number of steps/words	H05	Only the task code is input.	
H17	Forced cancel of all peripherals	H00	Normal completion	H00			
	Forced cancel of local station	H01	Normal completion	H00			
	Undefined	H02 to HFF	Abnormal task code	H01	Undefined subcommand	H02	Undefined subcommand is set.
	None		Abnormal task code	H01	Abnormal number of steps/words	H05	Only the task code is input.

Table. A.10 Task code response list (2 / 2)

Task code	Subcommand		Response task code		Return code		Error cause
		Code		Code		Code	
H40	None		Normal execution	H00			
			Abnormal task code	H01	Abnormal number of steps/words	H05	The requested number of points is outside the designated range.
					Abnormal I/O code	H06	The requested I/O type code is undefined or is an I/O that cannot be forced to be set.
					Abnormal I/O No.	H07	The requested I/O type code is undefined or is an I/O that cannot be monitored.
Warning	H02		Local station is not occupying CPU.				
H42	None		Normal execution	H00			
			Abnormal task code	H01	Abnormal number of steps/words	H05	The requested number of points is outside the designated range.
					Abnormal I/O code	H06	The requested I/O type code is undefined.
					Abnormal I/O No.	H07	The requested I/O No. is outside the designated range.
Not-executable	H03	Not occupied	H07	Local station is not occupying CPU.			
H44	None		Normal execution	H00			
			Abnormal task code	H01	Abnormal number of steps/words	H05	The requested number of points is outside the designated range.
					Abnormal I/O code	H06	The requested I/O type code is undefined or is an I/O that cannot be forced to be set.
					Abnormal I/O No.	H07	The requested I/O type code is undefined.
Warning	H02		Local station is not occupying CPU.				
H45	None		Normal execution	H00			
			Abnormal task code	H01	Abnormal number of steps/words	H05	The requested number of points is outside the designated range.
					Abnormal I/O code	H06	The requested I/O type code is undefined or is an I/O that cannot be forced to be set.
					Abnormal I/O No.	H07	The requested I/O No. is outside the designated range.
Not-executable	H03	Not occupied	H07	Local station is not occupying CPU.			
HA0	None		Normal execution	H00			
			Abnormal task code	H01	Abnormal number of steps/words	H05	The requested number of points is outside the designated range.
					Abnormal I/O code	H06	The requested I/O type code is undefined.
					Abnormal I/O No.	H07	The requested I/O No. is outside the designated range.
HA2	None		Normal execution	H00			
			Abnormal task code	H01	Abnormal number of steps/words	H05	The requested number of points is outside the designated range.
					Abnormal I/O code	H06	The requested I/O type code is undefined or is an I/O that cannot be forced to be set.
					Abnormal I/O No.	H07	The requested I/O No. is outside the designated range.
HA4	None		Normal execution	H00			
			Abnormal task code	H01	Abnormal number of steps/words	H05	The requested number of points is outside the designated range.
					Abnormal I/O code	H06	The requested I/O type code is undefined.
					Abnormal I/O No.	H07	The requested I/O No. is outside the designated range.
HA5	None		Normal execution	H00			
			Abnormal task code	H01	Abnormal number of steps/words		The requested number of points is outside the designated range.
					Abnormal I/O code	H06	The requested I/O type code is undefined or is an I/O that cannot be forced to be set.
					Abnormal I/O No.	H07	The requested I/O No. is outside the designated range.

A.3.5 I/O Code List

The list of the I/O codes used in task code is shown in the following table.

Table.A.11 I/O code list

I/O code	Symbol	I/O number
H00	X	0 to H4FF5F (4FF95)
H01	Y	0 to H4FF5F (4FF95)
H02	R	0 to H7FF
H03	L	0 to H03FFF, H10000 to H13FFF
H04	M	0 to H3FFF
H05	Timer / Counter	0 to H1FF (511)
H06	CL	0 to H1FF (511)
H07	(Not used)	-
H08	WX	0 to H4FF9
H09	WY	0 to H4FF9
H0A	WR	Depend on CPU type.
H0B	WL	0 to H03FF, H1000 to H13FF
H0C	WM	0 to H3FF
H0D	TC	0 to H1FF (511)
H0E	DIF	0 to H1FF (511)
H0F	DFN	0 to H1FF (511)

« Note »

- ◆ In the decimal expression of X and Y, the lower two digits are decimal and the upper three digits are hexadecimal.

Be sure to convert from decimal to hexadecimal only for lowest two digits.

Ex.) 4FF90 → 4FF5A

- ◆ In the decimal expression of WX, WY, the lowest digit is decimal and the upper three digits are hexadecimal.

A.4 TRNS 9 Return code

The return code of TRNS 9 command and error factors are shown in the following table.

Table A.12 TRNS 9 Return code (1 / 2)

No.	Error code	Item	Error level	Details
1	HFF	EH-CPU error	---	Since error occurred in CPU, EH-SIO also stopped operation.
2	(None)	Watch dog timer error	Serious error	MPU of EH-SIO stops having operated as the system program, and detected the abnormalities in MPU by the watch dog timer.
3	H03	OS system error	Serious error	The system OS of EH-SIO detected errors.
4	H21	Range check error	Warning	The last address of s, t parameter is over the range of I/O.
5	H22	Sending data area setting error	Warning	The head address of sending data area is not right.
6	H23	Sending data area range error	Warning	The last address of sending data area is over the range of I/O.
7	H24	Receiving data area setting error	Warning	The head address of receiving data area is not right.
8	H25	Receiving data area range error	Warning	The last address of receiving data area is over the range of I/O.
9	H28	Area overlap error	Warning	Area has overlapped. (s parameter, t parameter, sending data area, receiving data area)
10	H30	Command time-out error	Warning	TRNS 9 command was not completed within the specified time.
11	H40	Receiving data overflow	Warning	Receiving data was not able to store in receiving data area.
12	H50	Designated Invalid command	Warning	TRNS 9 was executed to the port used as the slave function or the simple data link function.
13	H51	Number of entry over	Warning	- Slot number is wrong. - The number of slave function or simple-link function is over the max. number.
14	H81	Command not-supported	Warning	- Command not supported. - Initializing duplicates.
15	H82	Initial setting error	Warning	- Parameter error in initializing - Initializing incomplete
16	H83	Transmission data error	Warning	Parameter error
17	H84	Receive buffer full	Warning	The input buffer of EH-SIO is filled with the receiving data which is not read by CPU.
18	H85	Connect error	Warning	Since DR signal from external device is OFF, data cannot be transmitted.

When EH-SIO detects serious failure, EH-SIO stops operation.

A gray cell is the error which CPU detects.

Table A.13 TRNS 9 Return code (2 / 2)

No.	Error code	Item	Error level	Details
19	H8A	Parity error	Warning	Parity error in receiving data.
20	H8B	Framing error	Warning	Framing error in receiving data.
21	H8C	Overrun error	Warning	Overrun error in receiving data.
22	H8D	Check code error	Warning	Check code error in receiving data.
23	H8E	Timeout error (Receive)	Warning	Reception of data was not completed within the time specified by EH-SIO.
24	H8F	Timeout error (Send)	Warning	EH-SIO did not complete transmission of data by within the time interval. (Monitoring time is fixed by the system. It cannot be changed.)
25	H90	Error message reception	Warning	Error message response was received. (Example: Modbus exception response reception, etc.)
26	H91	Message data error	Warning	A message containing inaccurate data was transmitted and received. (Example: The wording is correct as a telegram message, but the contents of the data are abnormal ASCII data.)
27	H92	Designated query error (Modbus mode)	Warning	Sent data (query) format is wrong.