

# HITACHI

## MICRO-EH (8/16 points type) Safety Precautions

Thank you for purchasing a Hitachi Programmable Logic Controller. To operate it safely, please read these safety precautions and all the user manuals carefully. Please be sure to use the latest versions of the user manuals and keep them at hand of end users for future reference.

1. It is not allowed to reprint any part of this manual without permission.
2. The content of this manual may be changed without notice.
3. While efforts have been made on this manual to be accurate, please contact us if any mistakes or unclear part is found.

### ■ Warranty period and coverage

The warranty period is either 18 months after manufacturing date (MFG No) or 12 months after installation. Examination and repair within the warranty period is covered. However within the warranty period, the warranty will be void if the fault is due to;

- (1) Incorrect use as directed in this manual and the application manual.
- (2) Malfunction or failure of external other devices than this unit.
- (3) Attempted repair by unauthorized personnel.
- (4) Natural disasters.

The warranty is for the PLC only, any damage caused to third party equipment by malfunction of the PLC is not covered by the warranty.

### ■ Repair

Any examination or repair after the warranty period is not covered. And within the warranty period any repair and examination which results in information showing the fault was caused by any of the items mentioned above, the repair and examination cost are not covered. If you have any questions regarding the warranty or repair cost, please contact your supplier or the local Hitachi Distributor. (Depending on failure part, repair might be impossible.)

## General cautions

### ■ Definitions and Symbols



**DANGER**

Indicates a potentially hazardous situation which, if not avoided, can result in serious injury or death.



**CAUTION**

Indicates a potentially hazardous situation which, if not avoided, can result in minor to moderate injury, or serious damage of product.



: Indicates prohibition



: Indicates Compulsion



**DANGER**

- Do not touch terminals during power ON. There is a danger of electric shock and/or injury.
- Be sure to install external safety devices outside of the PLC like emergency stop circuit or interlock circuit.



**CAUTION**

- Be sure that the rated voltage matches the power supply voltage of the unit. Otherwise, there is a danger of breakdown and/or injury and/or fire.
- Only qualified personnel shall carry out wiring work. Otherwise, there is a danger of breakdown and/or injury and/or fire.



**COMPULSION**

- Be sure to ground the unit. Otherwise, there is a danger of electric shock and/or malfunction.



**PROHIBITION**

- Do not modify or take apart the unit. There is a danger of breakdown and/or injury and/or fire.

### ■ Mounting

- This equipment must be placed within a suitable enclosure such a cabinet (key or tool entry) .
- Mount the PLC on a metal plate and install in a cabinet as follows.
- Be sure to ground the cabinet and the metal plate, otherwise there is a risk of malfunction.
- Install the PLC as described in user manual.
- Take appropriate measures when installing systems in locations :
  - Subject to static electricity or other forms of noise.
  - Subject to strong electromagnetic field.
  - Close to power supplies.
- Be sure to tighten mounting screws, terminal screws and connector screws.
- Check that devices with lock mechanism, such as an expansion cable and terminal blocks are locked properly.

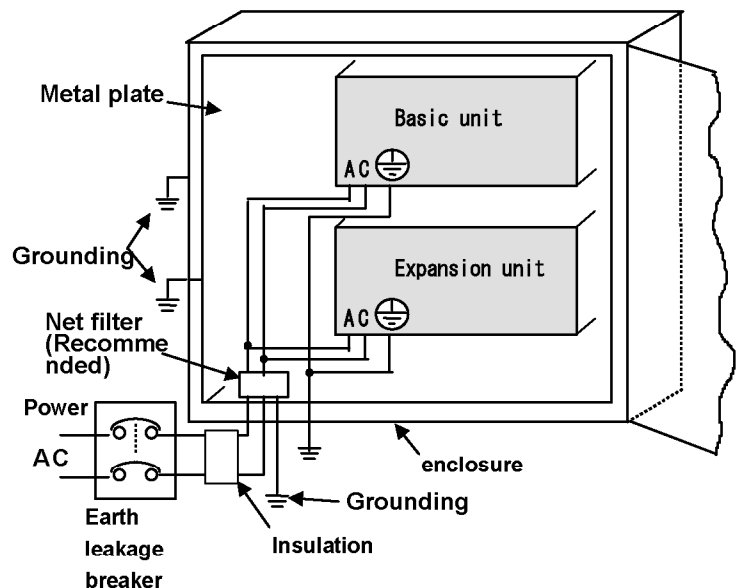

Figure 1 Power wiring example

## ■ General Wiring Procedures

- Use proper cable ferrules for terminals. Using improper cable ferrules or connecting bare wires to terminals directly might result in fire.
- Do not turn on power, if the unit appears damaged.
- Turn off power to the PLC before connecting field wiring. Otherwise, there is a risk of fire.
- Do not attempt to disassemble, repair or modify any part of the PLC.
- Do not pull on cables or bend cables beyond their natural limit. Otherwise, there is a risk of breaking of wire.

## ■ Power Wiring Procedures

- Appropriate emergency circuitry, interlock circuitry and similar safety measures should be added to the system.
- Appropriate safety measures should be included in the system unexpected breaking of wire or malsignal caused from instantaneous power failure.
- Applied voltage must be in the range specified in the manual. Otherwise, there is a danger of breakdown and/or injury and/or fire.
- Install an external earth leakage breakers to avoid short circuit accident.
- In case of the followings, turn off power. Otherwise, there is a danger of breakdown and/or injury and/or fire.
  - Mounting or dismounting CPU or I/O modules.
  - Assembling cabinet or machine including PLC.
  - Wiring.
- Install net filter specified in table-1. The input and output cable of the net filter should be separated as much as possible. Be sure to ground the net filter.
- A shielded and insulated transformer is recommended.
- The basic and expansion unit should be wired to a common power source and powered up together as shown in fig.1.

Table1 Net filter

Item	Spec.	
Rated voltage	250 V	
Rated current	5 A	
Withstand voltage (V) (between Terminal and case)	1500 V	
Insulation resistance (MΩ) (500VDC, 1 min., between terminal and case)	min. 100 MΩ	
Attenuation frequency range (MHz)	Differential mode, 40dB	0.5 to 30
	Common mode, 40dB	0.15 to 30

Reference : EMC filter ZAC2205-00U (TDK)

## ■ I/O Wiring Procedures

- Be sure that the input/output voltage matches the specified voltage. Otherwise, there is a danger of breakdown and/or fire.
- Route the AC power line and I/O lines should be separated as much as possible. Do not route both cables in a same duct.
- Route the I/O lines and data lines as close as possible to the grounded surfaces such as cabinet elements, metal bars and cabinets panels.

## ■ Other cautions

- Keep PLC modules in their boxes during storage and transport.
- Check carefully your PLC program before using.

## Environmental Conditions

Avoid the following locations to install the PLC.

- Excessive dust, salty air, or conductive materials (iron powder, etc.)
- Direct sunlight.
- Temperature less than 0°C or more than 55°C.
- Humidity less than 5% or more than 95%.
- Dew condensation.
- Direct vibration or impact to the unit.
- Corrosive, explosive or combustible gases.
- Water, chemicals or oil splashing on the PLC.
- Close to noise emission devices.

## ■ Reference Manual

Read the following application manual carefully to use the PLC safely and properly. Be sure to keep the latest version.

Manual name	Manual No.
MICRO-EH APPLICATION MANUAL	NJI-350(X)

The postfix of the publication number is subject to change for revision.

■ Terminal layout and wiring

1.EH-D16ED (DC power type)

\* For the DC input, it is possible to reverse the polarity of 24VDC.

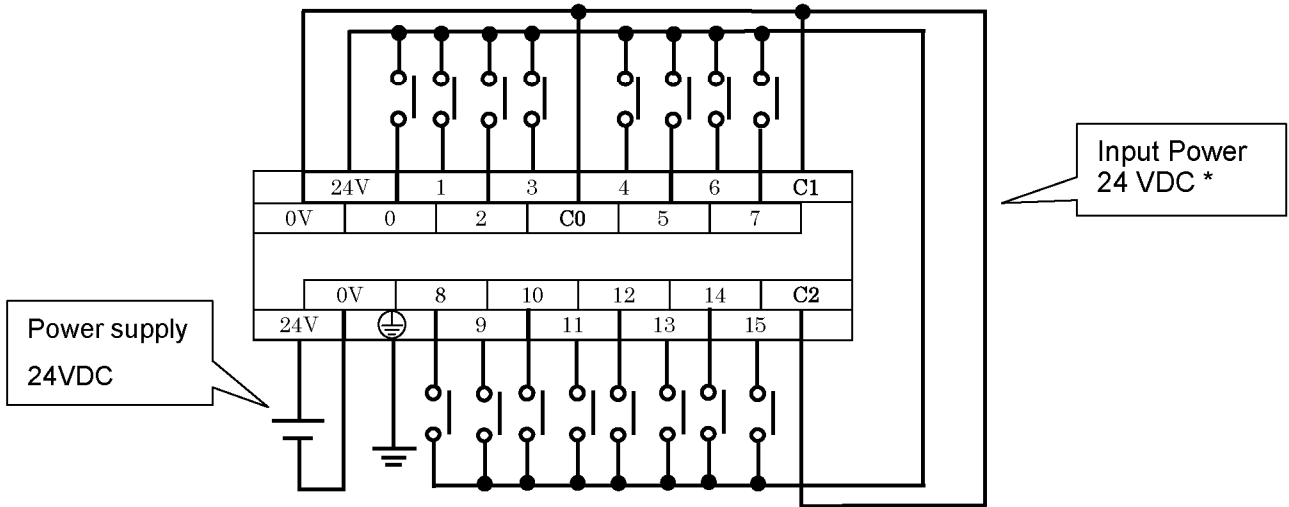

2.EH-D8ED (DC power type)

\* For the DC input, it is possible to reverse the polarity of 24VDC.

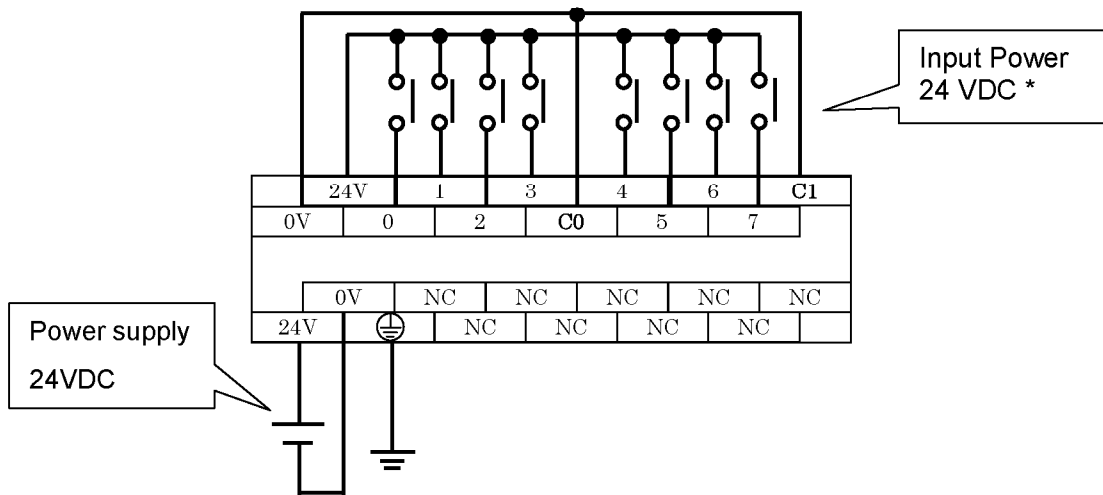

3.EH-D16ER (DC power type)

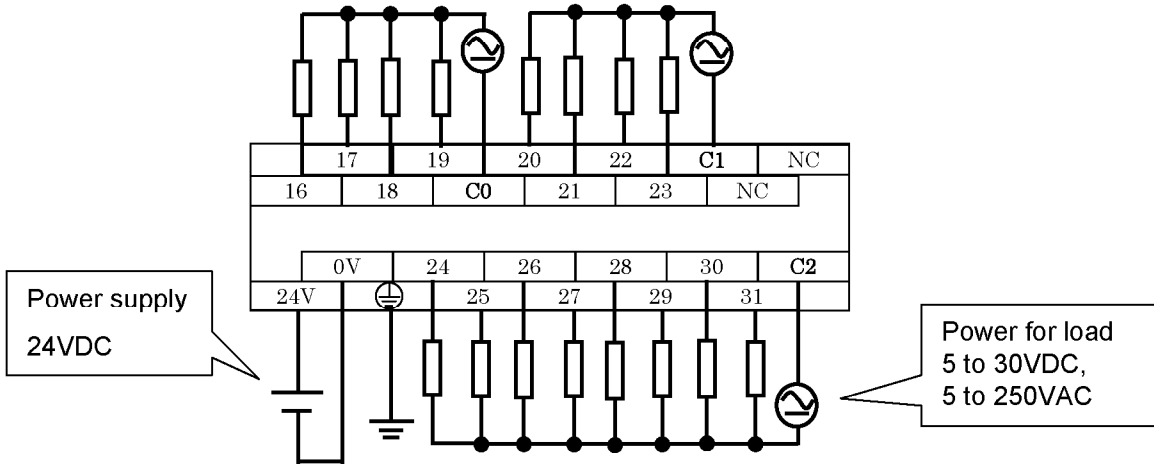

4.EH-D8ER (DC power type)

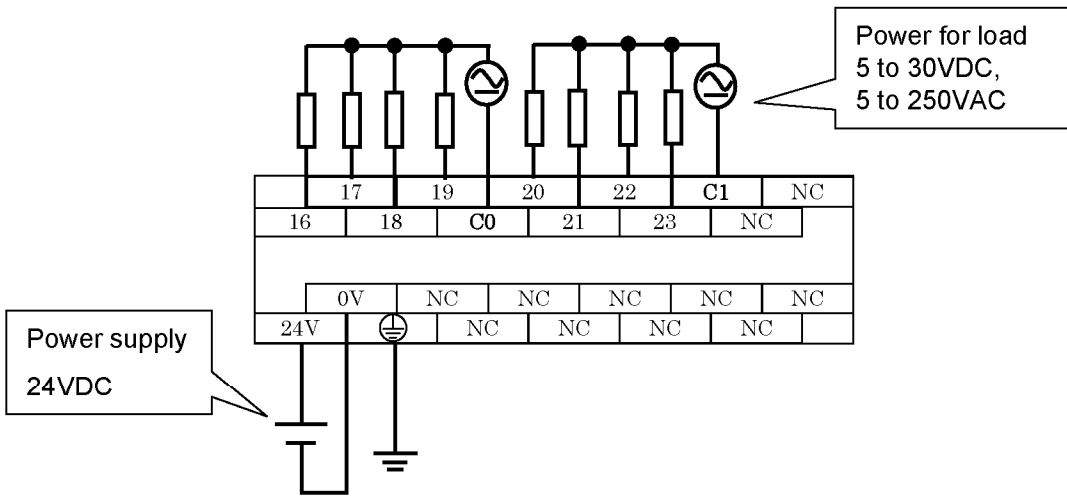

5.EH-D16ETPS(DC power type)

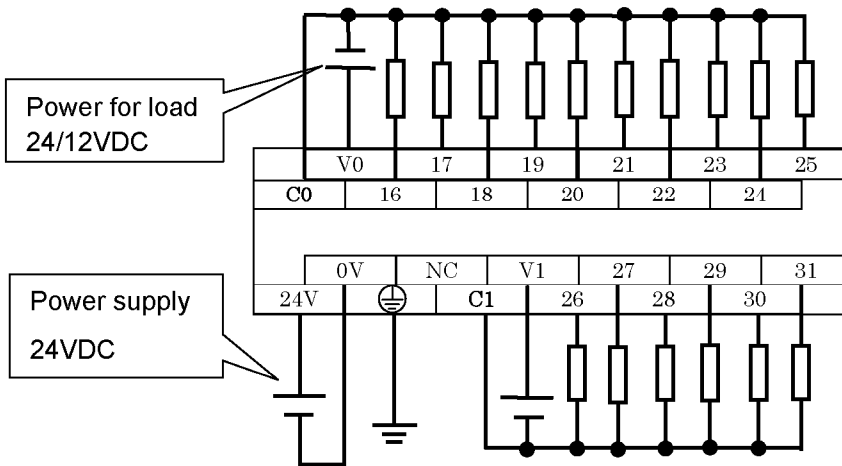

6.EH-D8ETPS(DC power type)

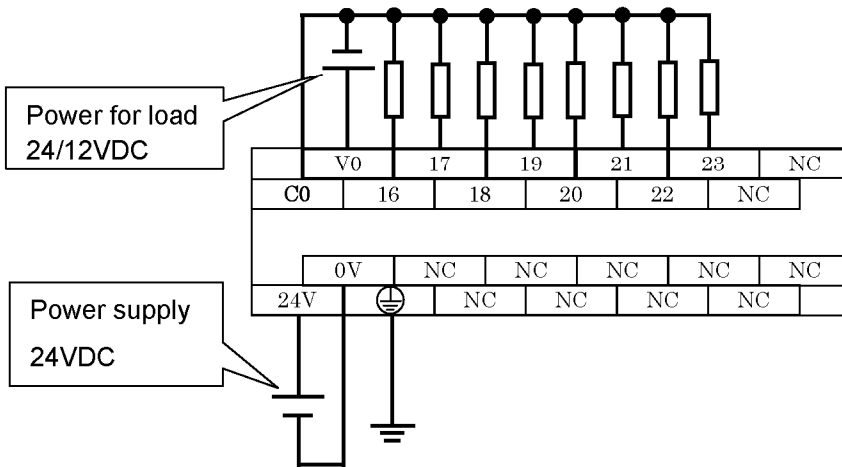

### 7.EH-D16ET(DC power type)

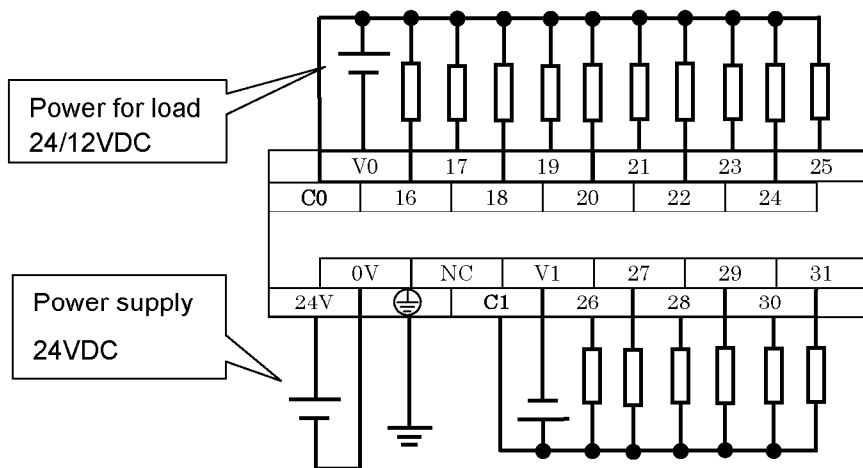

### 8.EH-D8ET(DC power type)

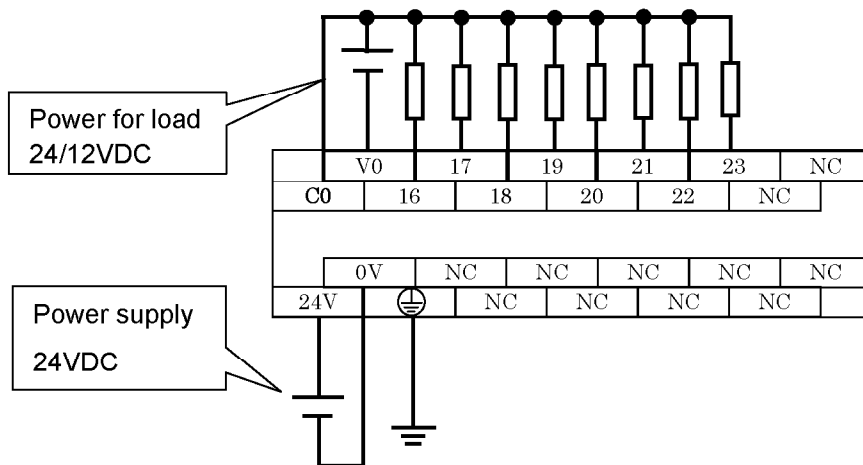

### 9.EH-D8EDR (DC power type)

\* For the DC input, it is possible to reverse the polarity of 24VDC.

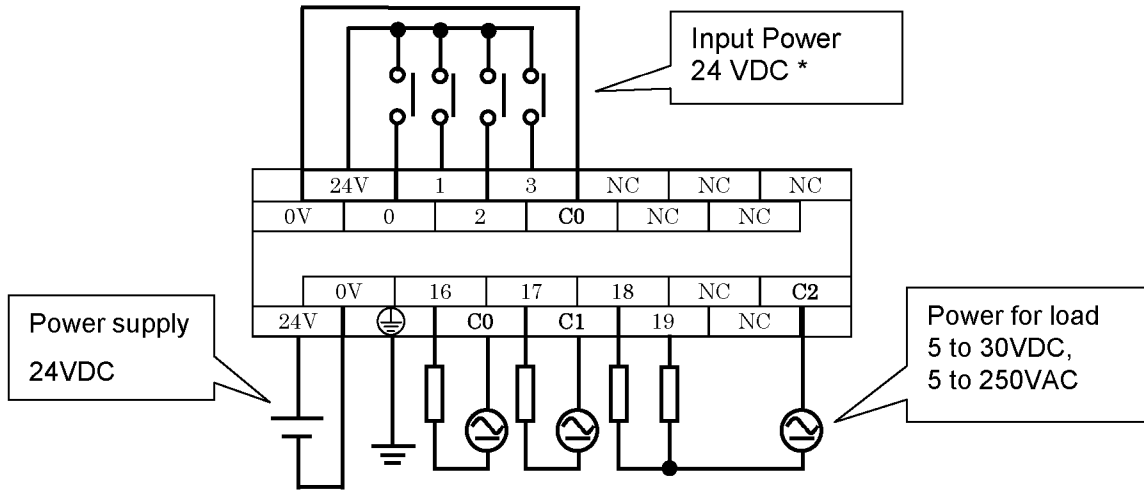

### 10.EH-D8EDTPS (DC power type)

\* For the DC input, it is possible to reverse the polarity of 24VDC.

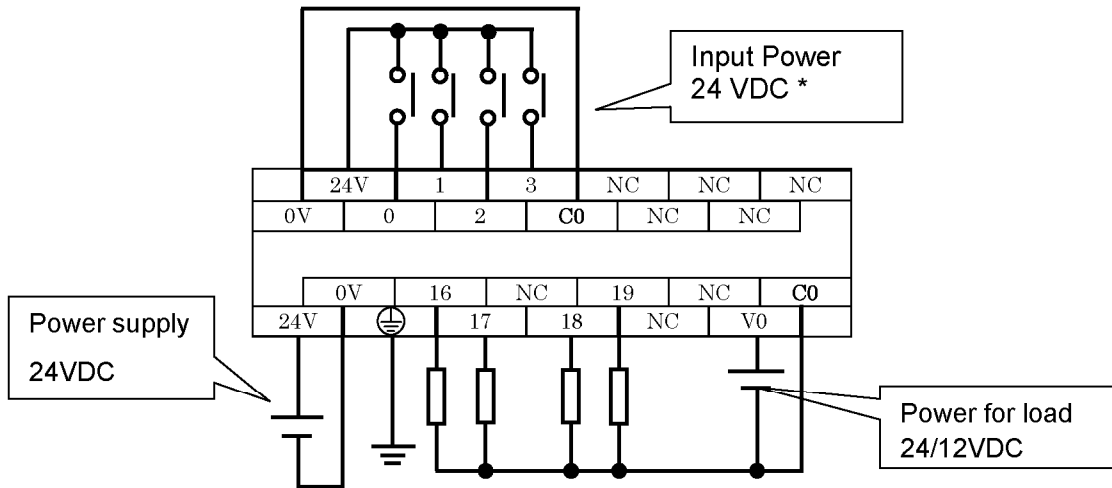

### 11.EH-D8EDT (DC power type)

\* For the DC input, it is possible to reverse the polarity of 24VDC.

